

A photograph of a modern industrial factory floor. In the foreground, a long, dark conveyor belt runs down the center. On either side of the belt, rows of white industrial robotic arms are positioned. The robots have multiple joints and are mounted on circular bases. The background shows a large, well-lit industrial space with a high ceiling and structural beams. The overall scene is clean and organized, representing a state-of-the-art manufacturing environment.

e-book

# An Engineer's Guide to Industrial Robot Designs

A compendium of technical documentation on robotic system designs



## 1. Introduction

- 1.1 An introduction to an industrial robot system. . . . . [3](#)

## 2. Robot system controller

### 2.1 Control panel

- 2.1.1 Using Sitara™ processors for Industry 4.0 servo drives. . . . . [9](#)

### 2.2 Servo drives for robotic systems

- 2.2.1 The impact of an isolated gate driver. . . . . [13](#)
- 2.2.2 Understanding peak source and sink current parameters . . . . . [17](#)
- 2.2.3 Low-side gate drivers with UVLO versus BJT totem poles . . . . . [19](#)
- 2.2.4 An external gate-resistor design guide for gate drivers. . . . . [20](#)
- 2.2.5 High-side motor current monitoring for overcurrent protection. . . . . [22](#)
- 2.2.6 Five benefits of enhanced PWM rejection for in-line motor control. . . . . [24](#)
- 2.2.7 How to protect control systems from thermal damage. . . . . [26](#)
- 2.2.8 How high precision in motor-drive control enables industrial advances. . . . . [29](#)
- 2.2.9 Getting the most out of your power stage at the full temperature range. . . . . [33](#)
- 2.2.10 Anything but discrete: how to simplify a 48-V to 60-V<sub>DC</sub>-fed three-phase inverter design. . . . . [35](#)
- 2.2.11 Selecting amplifiers for shunt-based current sensing in three-phase motor drives. . . . . [38](#)
- 2.3.1 Servo drive-related reference designs for robotic systems. . . . . [44](#)

## 3. Robot arm and driving system (manipulator)

- 3.1.1 How to protect battery power management systems from thermal damage. . . . . [45](#)
- 3.1.2 Protecting your battery isn't as hard as you think. . . . . [46](#)
- 3.1.3 Position feedback-related reference designs for robotic systems. . . . . [47](#)

## 4. Sensing and vision technologies

- 4.1 TI mmWave radar sensors in robotics applications. . . . . [48](#)
- 4.2 Intelligence at the edge powers autonomous factories . . . . . [53](#)
- 4.3 Use ultrasonic sensing for graceful robots. . . . . [55](#)
- 4.4 How sensor data is powering AI in robotics. . . . . [57](#)
- 4.5 Bringing machine learning to embedded systems . . . . . [61](#)
- 4.6 Robots get wheels to address new challenges and functions. . . . . [65](#)
- 4.7 Vision and sensing-technology reference designs for robotic systems. . . . . [66](#)

## 5. Technologies for robotic tools (end effector)

- 5.1 Achieving accuracy in bin picking with TI DLP® technology-powered structured light systems. . . . . [67](#)

## 6. Industrial communications for robotics

- 6.1 Selecting the right industrial communications standard for sensors. . . . . [69](#)
- 6.2 Enabling robots to achieve new levels of factory automation. . . . . [73](#)
- 6.3 Is your factory smarter than a fifth grader?. . . . . [76](#)
- 6.4 Industrial communications-related reference designs for robotic systems. . . . . [78](#)

# Chapter 1: Introduction

Analog and embedded technologies and reference designs from Texas Instruments (TI) enable engineers to develop intelligent, autonomous and collaborative robots. This e-book is intended to be a one-stop shop for robotics-related content.

Our technologies let you build numerous types of industrial robots with precise motor control, differentiated sensing technologies and processing at the edge, all with robust real-time communication. The primary types of robots discussed in this e-book are collaborative robots (cobots) and factory robots:

- Cobots work side by side with humans to improve work quality. A cobot can sense and stop movement, helping create a safer working environment.
- Factory robots perform automated programmable movements in manufacturing. In order to create a safer working environment, mechanical or sensor technologies can help keep robots from interfering with human activity.

There are six types of industrial robots:

- Vertically articulated.
- Cartesian.
- Cylindrical.
- Polar.
- Selective compliance assembly robot arm (SCARA).
- Delta.

All of these robot types offer a different axis configuration of the manipulator and include electronic content that enables the robot to manage its tasks. Task management is driven by advances in software, sensors and electronics, and has enabled the market for industrial robots to evolve over the last 50 years.

This e-book is a compilation of technical articles, white papers and application notes featuring TI's technologies suited for these industrial robot system building blocks:

- The robot controller system.
- The manipulator (robotic arm)/driving system.
- Sensing and vision technologies.
- The end effector (robot tools).

## 1.1 An introduction to an industrial robot system

Before describing the different technologies that go into a typical robotic system, let's discuss the different parts of a robot system, as shown in **Figure 1**. As you can see, the system is split into the different building blocks: the controller system, manipulator, teaching pendant, vision and sensors, and end effector (robot tools).

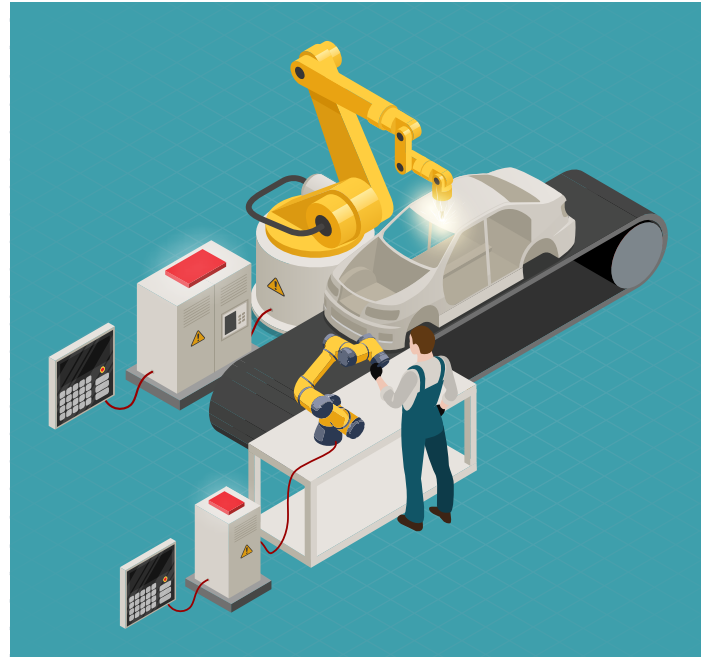

**Figure 1.** A robotic system featuring a cobot.

The International Organization for Standardization (ISO) 8373:2012 standard describes each of the building blocks shown in Figure 1 and defines terms used in relation to robots and robotic devices operating in both industrial and nonindustrial environments as:

- **The controller system.** The ISO 8373 standard states, “A set of logic control and power functions which allows monitoring and control of the mechanical structure of the robot and communication with the environment [equipment and users].” This is the robot’s brain, and can include a motion controller, both internal and external communication systems, and any potential power stages.

- **The manipulator.** The ISO 8373 standard also states “A machine in which the mechanism usually consists of a series of segments, jointed or sliding relative to one another, for the purpose of grasping and/or moving objects (pieces or tools) usually in several degrees of freedom or axes. A manipulator does not include an end effector.” The manipulator is commonly known as the robotic arm. It’s the part of the robot that defines how many axes the robot is implementing to achieve the movement required to perform a task.
- **The teaching pendant.** Multifunctional portable equipment used to program and teach an industrial robot. The pendant typically consists of an LCD touch panel, an enable button and an e-stop button. The teaching pendant connects to the robot controller system.
- **The robotic end effector.** A device connected on the robot “wrist” or end-of-arm tooling (EOAT). The system controller controls the robotic end effector by using either discrete input/output (I/O) for simple tools or industrial communication protocols for more advanced tools.
- **Vision and sensors.** These parts of the robot have the ability to scan the surrounding environment and stop (in the case of an industrial robot) or reduce (in the case of a cobot) a robot’s speed when humans approach. Vision/sensing is implemented with light detection and ranging (LIDAR), a radar-based safety area scanner or 3D cameras. In addition to the safety area scanner, cobots sometimes wear a sensor-based “safety skin” that stops the robot arm when a human touches it or is in proximity.
- **Cartesian.** These are also called rectilinear or gantry robots. Cartesian robots have three linear axes that use the Cartesian coordinate system (x, y and z). They may have an attached axis that enables rotational movement. Three prismatic joints facilitate linear motion along the axis.
- **Cylindrical.** This robot has at least one rotary axis at the base and at least one prismatic axis to connect the links. The rotary axis uses a rotational motion along the axis, while the prismatic axis uses linear motion. Cylindrical robots operate within a cylindrical-shaped work environment.
- **Polar.** Polar robots are also called spherical robots. For these types of robots, the manipulator connects to the base with a twisting axis and a combination of two rotary axes and one linear axis. The axes form a polar coordinate system and create a spherical-shaped work environment.
- **Selective compliance assembly robot arm (SCARA).** Commonly used in assembly applications, this selectively compliant manipulator for robotic assembly is primarily cylindrical in design. It features two parallel axes that provide compliance in one selected plane.
- **Delta.** These spider-like robots are built from jointed parallelograms connected to a common base. A delta robot has three axes for the parallelograms; for the end effector, it can have one to three axes. The parallelograms move a single EOAT in a dome-shaped work area. Heavily used in the food, pharmaceutical and electronic industries, this robot configuration is capable of delicate, precise movements.

When designing the building blocks of a robotic system, there are mechatronics, robot functions and electrical considerations that you need to understand and obtain specifications for before beginning the actual design.

Let’s discuss some typical considerations when defining the system architecture of a robot.

### What type of task is the robot supposed to do?

Different robot types have different advantages depending on the application. The typical types of industrial robots are:

- **Articulated.** This robot design features a rotary axis and can range from simple three-axis structures to 10 or more joints. The manipulator connects to the base with a twisting joint. A rotary axis connects the links in the manipulator. Each axis provides an additional degree of freedom, or range of motion.

### What amount of payload (weight) and reach will the robot have?

If the robot has to move heavy objects, it needs to have enough force on the motors to enable that capability. This force is generated with electric energy and is provided to the motor from the power stage. This power requirement is part of deciding whether the robot will be a high- or low-voltage system. A high-voltage robot system will require defined isolation architecture for safe operation.



### Will the electronics be centralized into the system controller?

In a centralized system, the robot controller cabinet includes most of the electronic modules that control the robot manipulator. **Figure 2** is an example of a centralized robot.

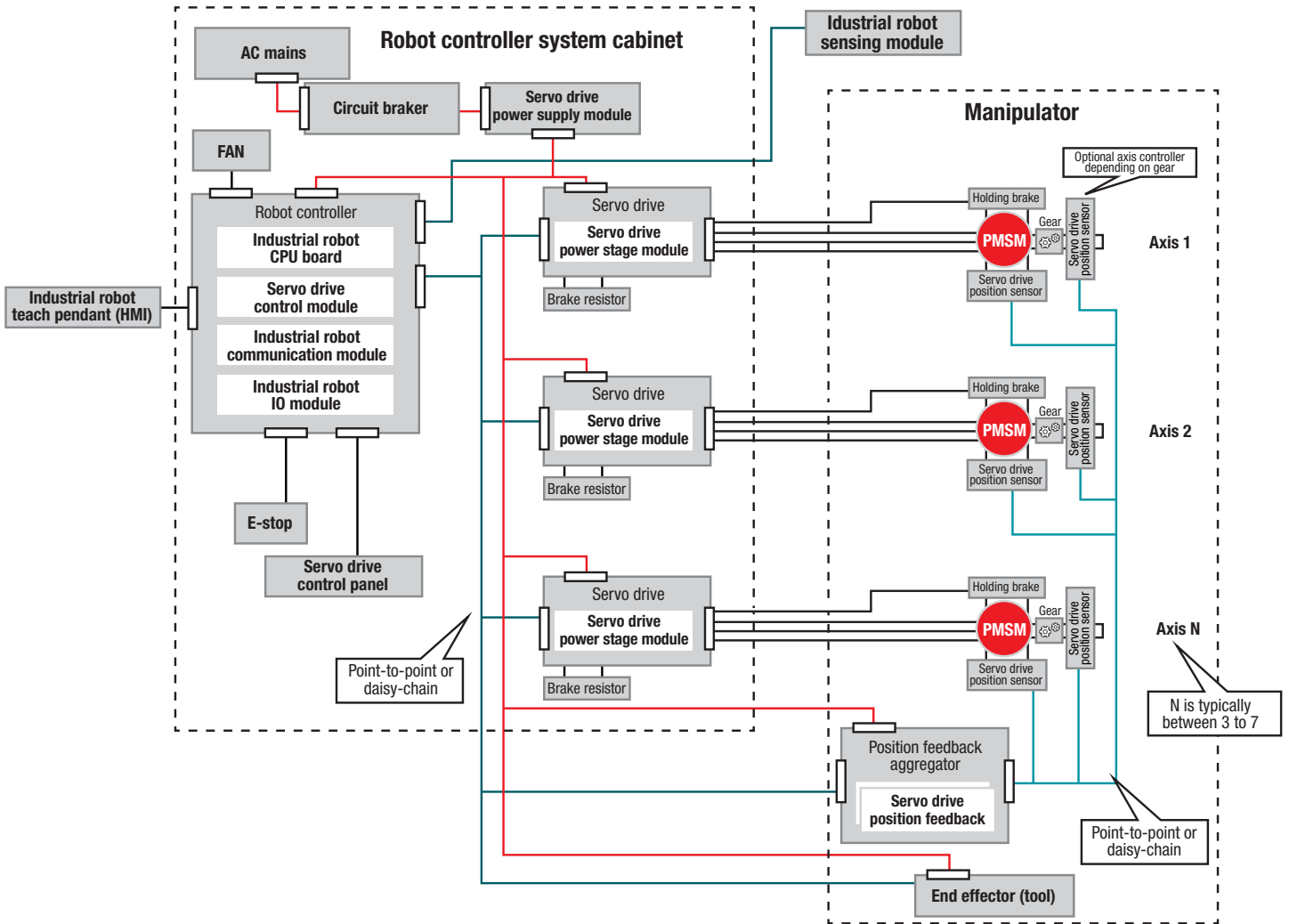

**Figure 2.** Example of a centralized robotic system.

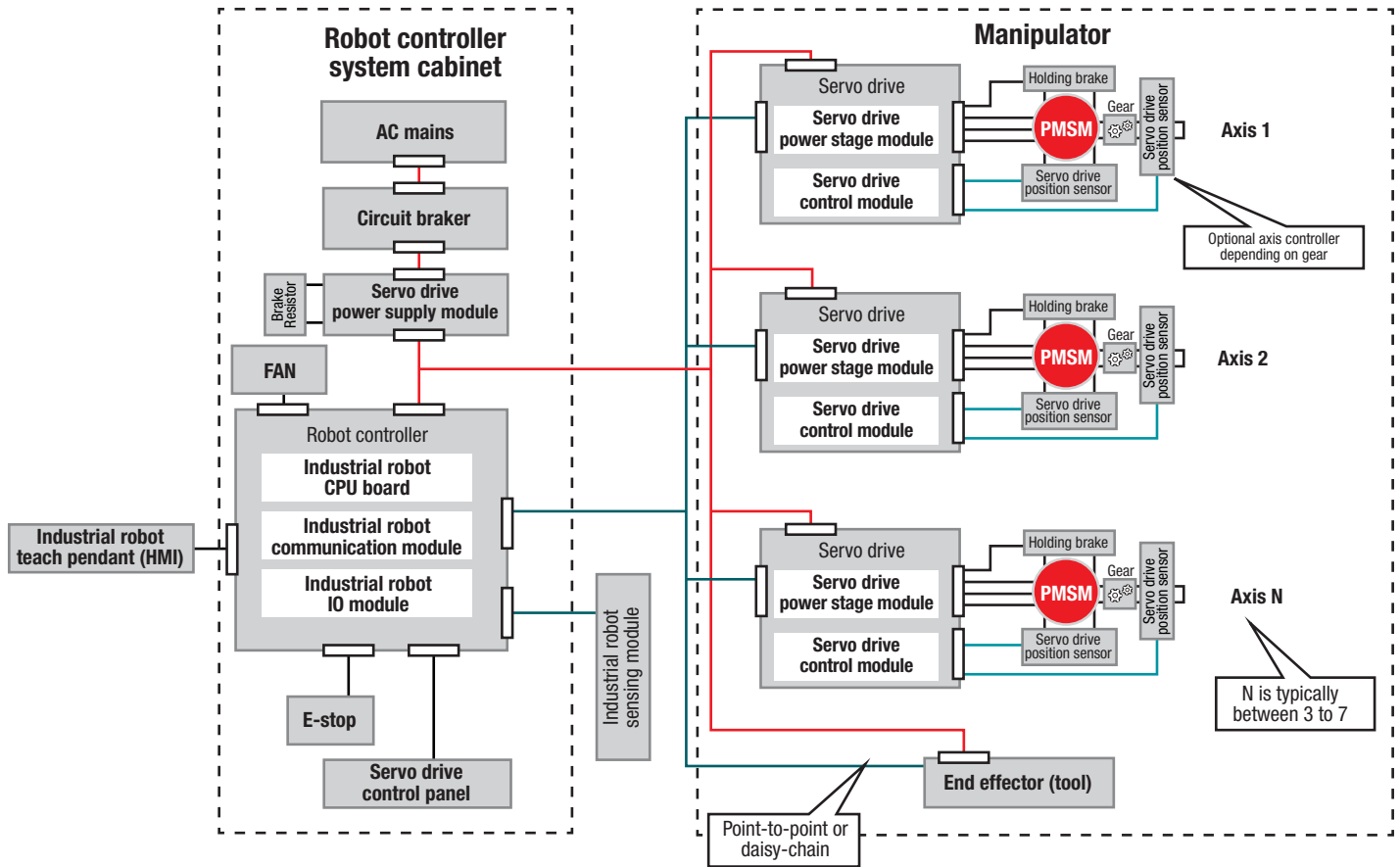

**Figure 3.** Example of a decentralized robotic system.

In a decentralized system, some of these modules move to the robot manipulator to support a variety of factors, including the form factor of the cabinet, cabling and more.

**Figure 3** is an example of a decentralized robot.

When decentralizing electronic content, it is important to remember that the environments where the electronics are now used are not the same as the environments of a centralized system. This environment change necessitates a re-specification of the electronics and typically requires redevelopment of part of the system.

**How will the different subsystems of the robot communicate with each other? What are the interface requirements?**

To ensure real-time functionality, you will need to define which control parameters pass between the subsystems, and the repetition rate and latency of the parameters for both the end effector and manipulator communication.

**Figure 4** includes some typical real-time timing values for a robot.

Now that the robot can move, it needs to know how to move, which leads to the next series of questions.

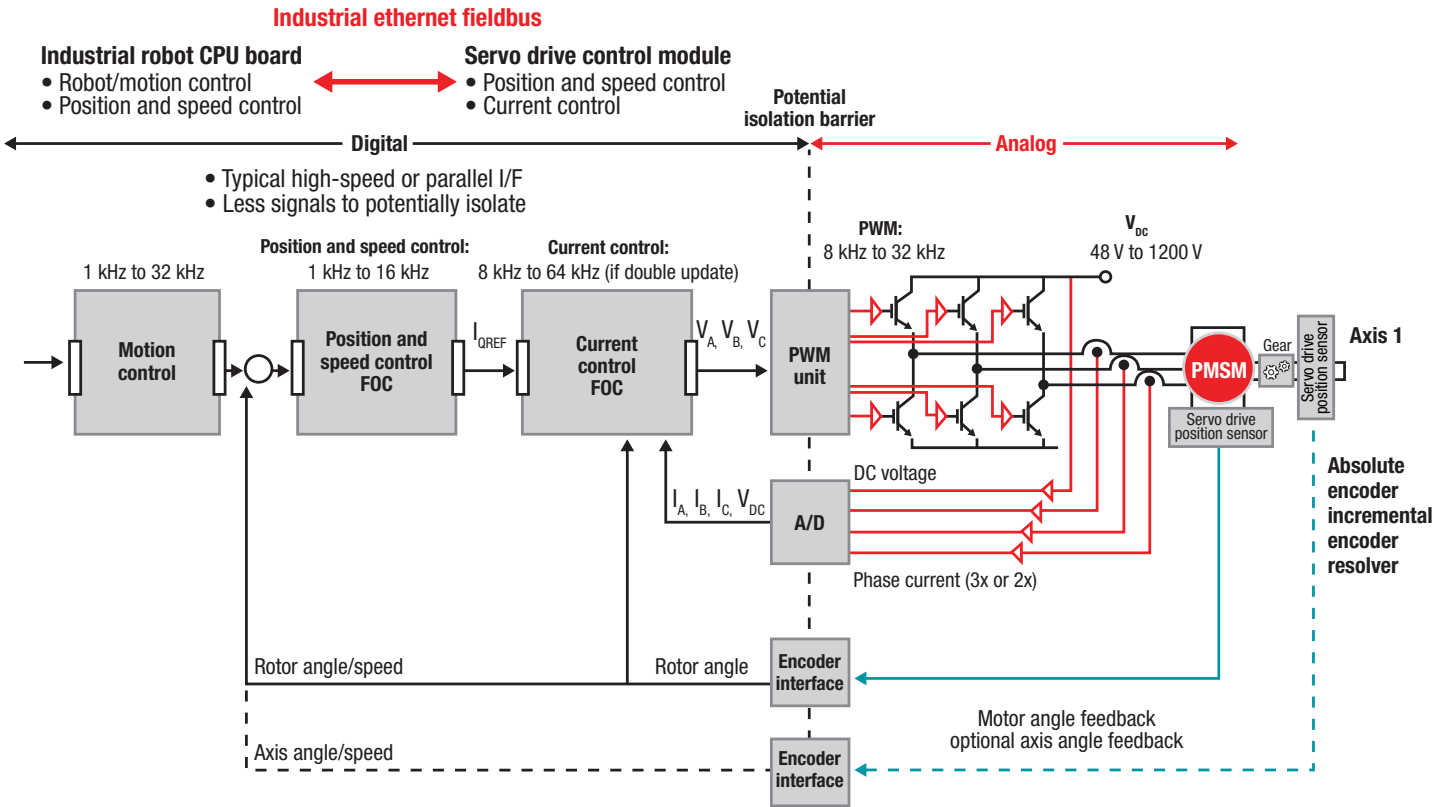

Figure 4. Real-time communication timing needs for robot control.

**How does the programming interface work? Will the robot operate from the user interface or through task programming? Will you need an extra interface to connect the teaching pendant or joystick in order to enable operator functionality?**

It's important to answer these questions early in the design process. Figure 4 also includes some of the design considerations of motion-control timing. And now, for the final question.

**Is the robot a nonadaptive robot or an adaptive robot?**

A nonadaptive robot does not receive feedback from the environment and will execute its task as programmed. Adaptive robots use input and output data to generate environment data. With this data, the robot can react to environmental changes and stop its task if necessary.

For adaptive robots, it is important to define the environment data to which the robot is reacting. The data might be pre-defined parameters, like material amounts or sizes or shapes for quality definitions. Or it might be uncontrolled parameters, like having people move around the robot or malfunctions that when detected put the robot in a safe state.

An adaptive robot requires a sensing module. An area safety scanner or safety skin is placed either at the base of the robot or attached somewhere on top of the robot. It supervises the surrounding area of the manipulator and prevents humans or other machines from getting too close to the robot; if they do, the robot stops or slows down.

You should follow both worldwide and local safety standards when designing robotic systems. Starting the design efforts before looking into relevant standards can considerably delay time to market. Several organizations offer consulting services to help you understand the hardware implications of designing a safe system according to safety standards, including Technischer Überwachungsverein (TÜV) – Rheinland, TÜV – Süd and TÜV – Nord.

### **Conclusion**

A robot is a very complex system with many design challenges within mechatronics and functionality, as well as electrical considerations. You'll need to solve these challenges or make some decisions before a working system is possible.

With all of the different technical aspects of a robotic system, analog and embedded technologies from Texas Instruments offer many different products and designs that can help solve robot-related issues and enable the development of intelligent, autonomous and collaborative robots.

This e-book is a compilation of technical articles, white papers and application notes featuring technologies to help you design your next robotic system.

Authored by: Kristen Mogensen



## 2.1 Control panel

### 2.1.1 Using Sitara™ processors for Industry 4.0 servo drives

The manufacturing and automation industries have used servo motor control for many years, but the rise of Industry 4.0 and smart factories has accelerated the adoption of automated systems, which in turn has led to increased demand for smarter servo drives with more functionality and the ability to control more axes.

Historically, high-end microcontrollers and large field-programmable gate arrays (FPGAs) performed the low-level control algorithms and provided peripherals to connect to the drive output and motor feedback. The requirements for what a servo drive must support are rapidly changing, however, as equipment gets smarter and higher in performance. Features like network communications, functional safety, predictive maintenance and programmable logic controllers (PLCs) are being brought into the servo control board to optimize cost and space by removing external boards. This increased level of integration and need for higher performance are leading designers to look to heterogeneous processors, such as [Sitara™ processors](#) from TI, to handle the majority – or all – of the processing needs for Industry 4.0 applications.

### Performance

In servo motor-drive applications, motor control is typically separated into several control-loop layers: the current/torque loop, speed loop, position loop and a higher-level motion-control loop. These loops are typically arranged in a cascade, each with their own real-time processing requirements. The current or torque loop is the tightest control loop. Each upstream loop runs at a multiple of the loop before it and provides input references to the downstream loops. **Figure 1** shows a typical cascaded control topology.

The blocks in Figure 1 lend themselves well to logical partitioning across cores within a heterogeneous processor, or between a processor and a microcontroller. Spreading the various loops among the different cores in a multicore processor maximizes the processing bandwidth dedicated to each loop. When a processor core receives its control-loop input data, it can run the algorithm to completion as quickly as possible, provide the reference value for the downstream loop and then continue providing other services until the next set of input data is ready.

Processors with higher raw performance can finish the control processing faster and have more bandwidth available to provide additional services and features. Fast processing is especially crucial when cycle times approach 31.25  $\mu$ s in a

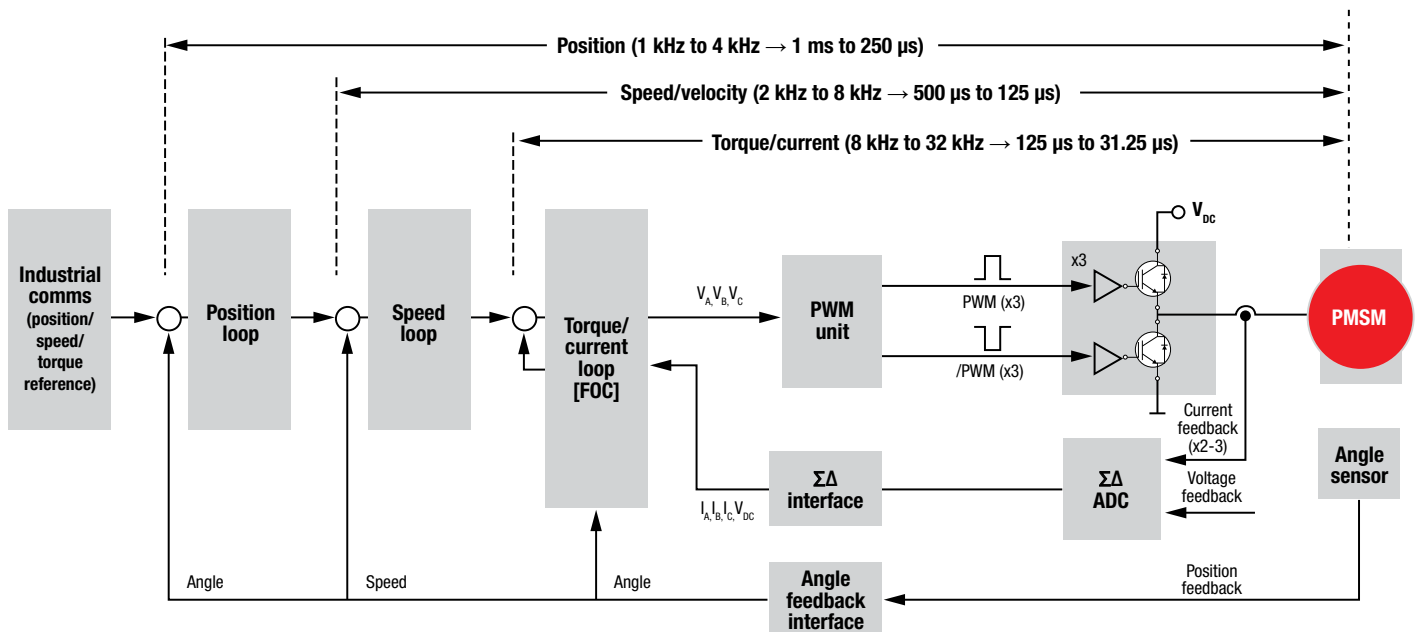

**Figure 1.** Typical servo-motor control-loop technology.

32-kHz control loop or when inputs from multiple axes must be processed nearly simultaneously.

There are a few options for the strict real-time processing requirements of servo control, including [digital signal processors \(DSPs\)](#), FPGAs and standard Arm® processing cores. Choosing the right processing core can be difficult because there's a balance between flexibility and optimizing control algorithms. In the past, optimizing control algorithms was the number one priority, so DSPs, application-specific integrated circuits (ASICs) and FPGAs were the clear choice.

Now, the need to add Industry 4.0 services to servo drives has resulted in the adoption of standard Arm Cortex®-A and Cortex-R cores. Cortex-A cores can achieve very high bandwidths, which is good for rapid processing, but they lack the real-time component of the Cortex-R, which is why Cortex-R is a better fit than the Cortex-A for servo control. On the other hand, the Cortex-A is much better suited than the Cortex-R for many other services, such as networking or predictive maintenance. Fortunately, multicore devices like Sitara AM6x processors can contain all of the processing elements mentioned here, enabling all necessary elements in a single chip.

### Industrial communication

Industry 4.0 brings many new and exciting things to the factory, but the rapid adoption of multiprotocol industrial Ethernet is among the most noticeable in the industrial servo drives sector. There are over a dozen different communication protocols on the market for industrial Ethernet, field bus and position encoders, each with its own pros and cons. EtherCAT, PROFINET and EtherNet/IP are the most popular Ethernet-based protocols in the servo drives market, while Hiperface Digital Servo Link, EnDat 2.2 and Bidirectional Interface for Serial/Synchronous C are among the more popular position-encoder protocols.

Many of these protocols have ASICs that you can attach to host processors to support that specific communication protocol. In some cases, with a multichip solution, the protocol's stack runs on the host processor and the ASIC

performs the media access control layer. Manufacturers who only plan to support a single protocol prefer this distributed architecture, since ASICs are typically optimized for that specific communication standard. Once the need to support multiple protocols arises, a multichip solution loses its attractiveness for multiple reasons. Each new protocol requires that you familiarize yourself with a new device (which adds development effort and cost). Manufacturers must maintain several versions of their boards for each of the different protocols.

Solutions such as Sitara processors have integrated multiprotocol support onto the host processor, helping save costs, board space and development effort, while also minimizing the latency associated with communication between external components and the host. A single platform supporting multiple standards enables you to maintain a single board for the different versions of your end product.

If you need to future-proof your products, you must also take into account the need to support time-sensitive networking (TSN). The platform you choose for industrial communication must be flexible enough to adapt to evolving TSN standards, or you risk it being outdated once the standards are finally set. The Sitara AM6x processor family provides a solution through its flexible programmable real-time unit-industrial communications subsystem (PRU-ICSS), which enables gigabit TSN as well as traditional 100-Mbps protocols like EtherCAT.

### Functional safety

The trend toward autonomous machine decision-making and operation, as well as increased human-machine interaction in potentially dangerous factory environments, means that functional safety is becoming more important for many applications in a smart factory, including servo drives. For a detailed description of functional safety standards and how Sitara processors play in the industrial environment, read the white paper, "[The state of functional safety in Industry 4.0.](#)"

### System partitions

The cascaded control loops in a servo drive typically span at least two circuit boards, separated by a reinforced isolation boundary. This isolation boundary creates what's referred to as a "hot side" and a "cold side." The hot side is closest to the motor and includes the high-voltage components that supply power to the motor. The cold side is on the other side of the isolation and typically holds the control units.

The modular nature of the various control loops in a motor drive give you many possibilities when partitioning your system across the isolation boundary. Figures 2, 3 and 4 show a few possible partitions of a servo drive.

**Figure 2** shows a two-chip solution, with the two system on chips (SoCs) separated by the isolation boundary. The benefit

of this architecture is that the total time for the field-oriented control loop to get inputs from the motor and return a current is short, because the entire loop runs on the power-stage board.

**Figure 3** also shows a two-chip solution, but this time both SoCs on the control board are on the cold side. The control loop is split between two SoCs: one handles the algorithm processing and the other acts as an aggregator and provides pulse-width modulators (PWMs) across the isolation boundary. The benefit of this architecture is that it enables the use of lower-cost power-stage boards but maintains the same performance levels, whereas the partition shown in Figure 2 requires a high-speed interface between the two SoCs.

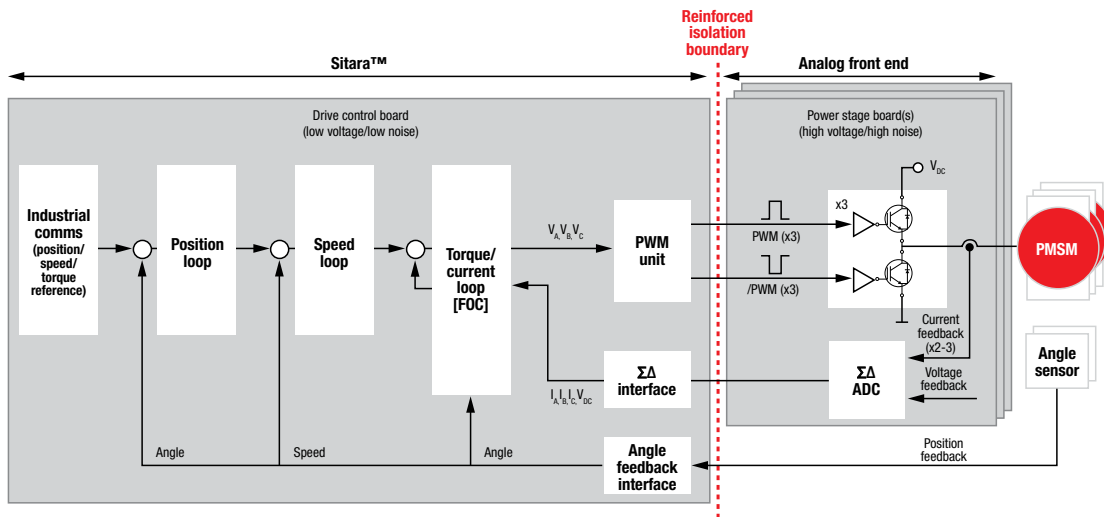

**Figure 2.** A Sitara processor communicating across the isolation boundary to a separate control unit on the hot side of the system.

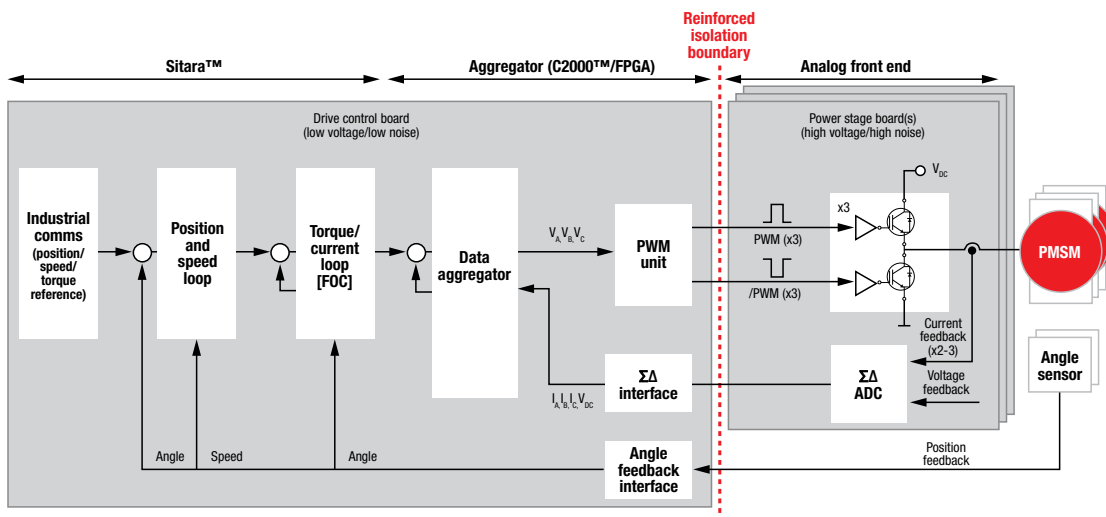

**Figure 3.** A Sitara processor acting as a servo processor, with different control functions offloaded to a C2000 microcontroller or FPGA on the cold side of the system.

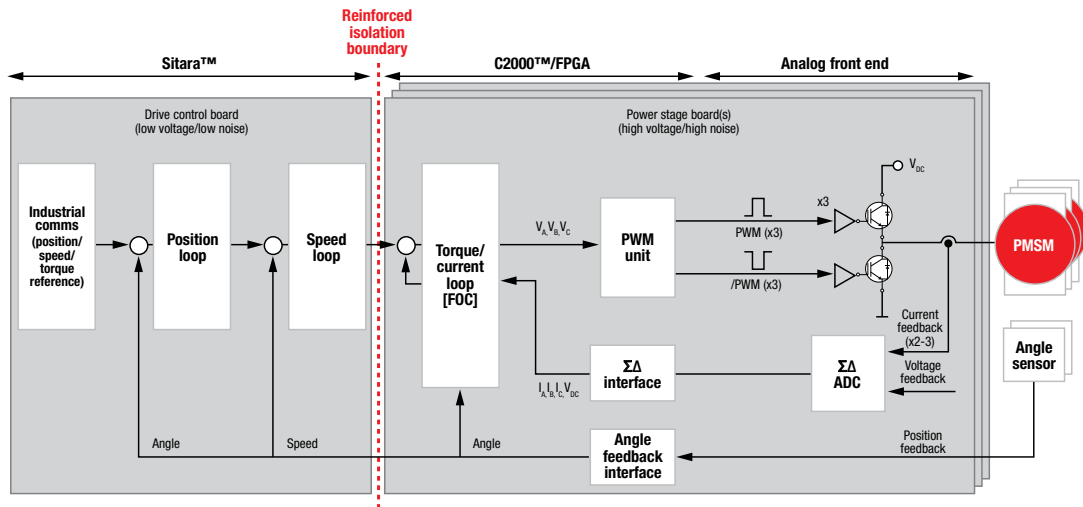

Figure 4. Using a Sitara™ processor to implement full servo control on the cold side.

In Figure 4, the entire control loop including the PWM and motion profile generation (typically handled by a PLC) is integrated into a single SoC on the cold side. This architecture enables even more cost savings through integration and eliminates the latency associated with the interface between SoCs.

### Solutions from TI

The Sitara processor family has SoCs to handle everything from stand-alone industrial communication modules to fully featured multi-axis servo drives for the system partitions discussed in this chapter. Figure 5 shows what is possible with the different processors within the Sitara, Hercules™ and C2000™ real-time microcontroller families. Sitara AMIC processors contain the PRU-ICSS subsystem and have been optimized for stand-alone multi-protocol industrial communications modules.

The rest of the Sitara family integrates the PRU-ICSS subsystem, along with other cores and peripherals, to enable control and communications. The AM6x processor family takes integration one step further by offering integrated safety features based on Hercules microcontrollers to enable a single-chip solution for communications, servo control and some levels of functional safety.

### Conclusion

Industry 4.0 is introducing new guidelines and system requirements for servo drives, making it important for designers to select a solution that fits the needs of current and future servo drives. Devices like Sitara AM65 processors, which include both Cortex-A and Cortex-R cores and support 100-Mbps and 1-Gbps industrial networking, are capable of supporting existing and future servo drives. TI also offers a variety of products, including other Sitara processors and C2000 microcontrollers, to serve the changing needs of the industrial market.

Servo drive products from TI		Sitara™ AMIC110 Processor	Sitara™ AM335x Processors	Sitara™ AM437x Processors	Sitara™ AM57x Processors	Sitara™ AM6x Arm processors	Hercules™ MCU	C2000™ Real-time Microcontrollers	C2000™ Real-time Microcontrollers
Product		AMC110 processors	AM335x processors	AM437x processors	AM57x processors	AM6x Arm processors	Hercules MCU	C2000 F2838x MCU	C2000 F28004x MCU
Safety	Integrated functional safety features					✓	✓	✓	✓
	Time-sensitive networking (TSN)					✓			
Industry 4.0 services	Integrated security features		✓	✓	✓	✓		✓	✓
	Predictive maintenance		✓	✓	✓	✓		✓	✓
Control	High-speed serial interface				✓	✓		✓	✓
	Integrated servo motor control			✓		✓		✓	✓
Communications	Industrial Ethernet	Multi-protocol	Multi-protocol	Multi-protocol	Multi-protocol	Multi-protocol		EtherCAT®	

Figure 5. TI processing products available for servo drives.

## 2.2 Servo drives for robotic systems

### 2.2.1 Impact of an isolated gate driver

With information exchange and urbanization rising at a global level, the need for power management is becoming more critical than ever.

This affects high-efficiency and robust systems that require power electronics with sophisticated intelligence in order to meet the demands of power consumption. Several day-to-day applications that necessitate these requirements are data centers, telecommunications base stations, industrial automation, motor drives and grid infrastructure. Each has their own power-level requirements, topologies and appropriate choice of power switches.

For example, data centers and telecommunications applications use power metal oxide semiconductors (MOSFET) simply because these applications need to switch faster while increasing the system power density. On the other hand, industrial automation and motor drives typically deploy insulated bipolar gate transistors (IGBT) due to their high voltage requirement and higher power levels. Grid infrastructure equipment such as solar inverters have the flexibility to choose any of the power switches, depending on the inverter type and power level.

Human machine interface (HMI) is involved in these applications. Additionally, intelligent systems such as controllers and communication peripherals need protection from the high-power and high-voltage circuitry. This is achieved through isolation. Also, integrating the isolation circuitry with the power transfer components helps to reduce system size cost. One key trend is to integrate the gate driver with an isolator (the device that performs the isolation function) known as the isolated gate driver. This is becoming a key trend that makes these system-level features attractive.

This section of the e-book is twofold. The first is to understand why an isolated gate driver has become so attractive, which is illustrated by walking through an application. The second is to identify the requirements of an isolated driver as a function of the power switch.

## Why use an isolated gate driver?

### Data center application

The demand and availability of information transaction and retrieval is ubiquitous. Time is seldom wasted in using a smart device, for example. Check out what is in our social media, our messages or email. All this is happening in the cloud. This cloud is the workhorse of real-time connectivity across the globe. The cloud is physically located in a data center.

Information to and from the data center is transmitted through a line such as fiber or coax cable, or wireless through telecommunications base stations. Inside the data center is the power delivery unit, commonly referred to as the power supply. Information is stored in servers, known as cloud servers. These servers need power to store and retrieve information back and forth to the users. These power supply units are in the range of a few hundred to thousands of watts. They operate off the grid, which is the AC line voltage in the range of hundreds of volts. Hence, they are referred to as the high-voltage unit.

There are several low-voltage components such as controllers and communication components required to improve server efficiency. Moreover, these servers are sold based on their efficiency ratings and therefore are becoming mandatory to maintain those ratings. In addition, there are humans involved in the cloud operation interacting with the servers through HMIs. It is important to avoid any breakdown and leakage of current from the high-voltage unit into the HMI as it could damage all the low-voltage components, such as controllers and communications.

### Isolation is the answer

An [isolation device](#), which is a semiconductor integrated circuit (IC), allows data and power to transfer between the high-voltage and low-voltage units, while preventing any hazardous DC or uncontrolled transient current flowing from the grid. One well-known example is a lightning strike. Isolation is a means to break the ground loops created in circuits that have high-energy flow. There are several methods of isolation. Of all, galvanic isolation is the one that provides protection for very large potential differences.

Day by day this demand for power continues to increase. Not only that, people expect to receive this information instantaneously. This means that data center capacity is growing by the day with increasing data demand, which means that power delivery systems need to supply more and more power. However, the data center has limited real estate constraints. Scaling them to a larger size is expensive and highly uneconomical.

One way to address this demand is to increase power density and provide isolation robustness. This can be done by significantly improving power supply efficiency and increasing the power transfer rate, also known as switching frequency measured in kHz. This improvement helps to make the power supply units smaller. Isolation robustness is realized by integrating the isolator with a key power component: the high-speed gate driver. This integrated device is known as the isolated gate driver.

### Gate driver functionality

To further understand the value of such an integrated solution, first you need to understand how a gate driver is used. **Gate drivers** are implemented in a system that operates under switched-mode power where the power switch operates in an ON and OFF mode, thereby consuming zero power, ideally under high-switching frequencies. Two common power switches used are the **power MOSFET** and IGBT. Switched-mode power operates in a controller-based, closed-loop power topology. Controlling the ON/OFF status happens at the gate of these switches in order to regulate voltage and the flow of current through the switches. Take a power MOSFET, for example.

**Figure 1** illustrates how the gate terminal works.

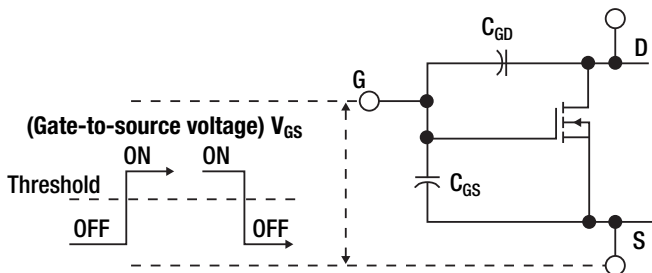

**Figure 1.** Control of a gate terminal in a power switch.

First off, the GATE terminal controls a MOSFET's ON/OFF state.  $V_{GS}$  is the voltage between gate and source.

- To turn ON, apply a positive voltage,  $V_{GS} >$  threshold level.
- To turn OFF, reduce  $V_{GS} <$  threshold level.
- GATE is a capacitive input with a high impedance.
- It has  $C_{GS}$ ,  $C_{GD}$  as two parasitic capacitances residing in the MOSFET's internal structure.

This is where the gate driver comes into play. It acts as a power amplifier that accepts a low-power input from the controller IC and produces the appropriate high-current gate drive for a power MOSFET to turn ON or OFF.

### Isolated gate driver versus traditional transformer isolation

Depending on where the controller is positioned or placed, isolation is required between the controller and the driver for high-voltage applications such as data center power supplies. A traditional method for isolation is using a gate driver transformer.

**Figure 2a** shows where the transformer is pulsed by a simple low-side, non-isolated gate driver to phase leg of a bridge topology (**Figure 2b**). This is referred to as Type A.

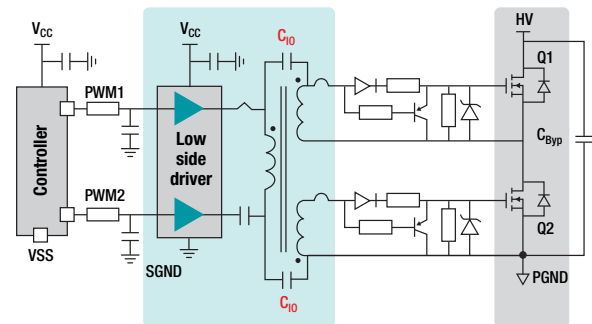

**Figure 2a.** Transformer isolation drives both high-side, low-side switches in a phase leg.

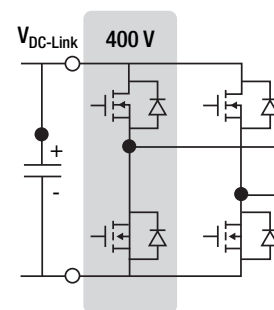

**Figure 2b.** One phase leg of a full-bridge topology.



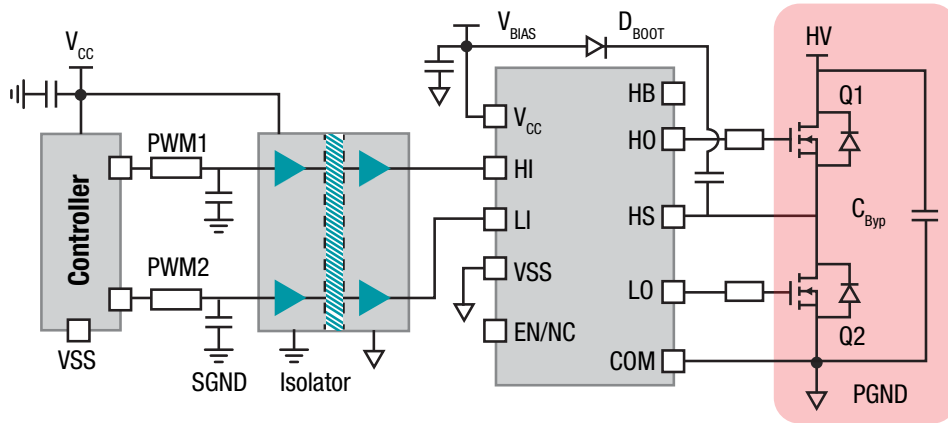

Figure 3. An isolator and a gate driver configuration highlighting a phase leg controller.

Now consider using an isolator IC instead of a transformer located between the controller and a high-side, low-side driver (Figure 3). This is referred to as Type B.

Table 1 shows a typical comparison between Type A and Type B.

Specifications	Type A	Type B
T <sub>Prop</sub>	≈20 ns	≈100 ns
Bias power	No	Yes
C <sub>io</sub>	≥10 pF	≤1 pF
Parasitics	Large (LLK)	Very small
Overshoot	Large	Small
Size	Bulky	Small

Table 1. Type A versus type B comparison.

Note that the size of the isolator and gate driver combination is small compared to the transformer isolation. However, the propagation delay, a key metric for high-power density applications, is significantly higher for Type B.

Now consider the isolator and the driver integrated into one IC or a multi-chip module as shown in Figure 4. This is referred to as Type C. This solution is the isolated gate driver.

Type C gives a propagation delay similar to or better than a discrete transformer solution while it also gives a significant area reduction greater than 50%. Furthermore, Type C can be tailored to deliver common mode transient immunity (CMTI) greater than 100 V/ns, a number significantly higher than that achievable by the Type A solution. CMTI is a key parameter that determines the robustness of a gate driver.

As explained in the data center application, system solutions are becoming smaller in size. This translates into a power supply with higher power levels and smaller board space. Integrating as many components as possible is vital, which is why this is the trend in power solutions. An isolated gate driver (Type C) is the answer to this trend. Galvanic isolation technology is typically capacitive, optical and inductive. Additionally, the isolation level (such as reinforced, basic and functional) depends on the application.

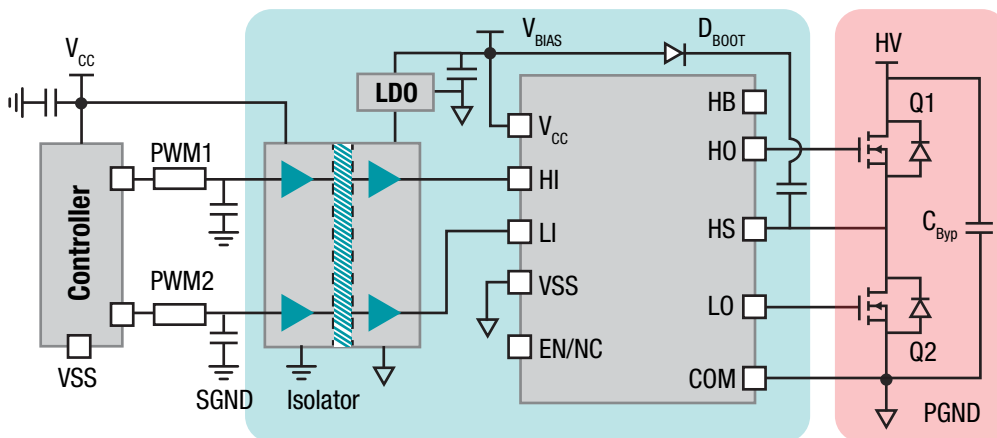

Figure 4. An integrated solution where an isolated gate driver drives a phase leg.

### Isolated driver as a function of power switch

Isolated driver functionalities are very similar to a non-isolated gate driver such as:

- Propagation delay.
- Common-mode transient immunity (CMTI).
- Rise time/fall time.
- Maximum driver-side supply voltage.
- UVLO.
- Channel-to-channel delay.
- Protection schemes.
- Dead time control and overlap.
- Enable/disable features.

The importance of a specification parameter is dictated by the application. For example, power supplies used in data center servers and telecommunications infrastructure operate at high-switching frequencies above 20 kHz.

For such applications where a power MOSFET is used, minimizing switching loss is key. This makes parameters such as rise time/fall times and propagation delay very important. Alternatively, applications like motor drives and high-power (> 5 kW) solar inverters operate at switching frequencies in the range of 5 kHz to 20 kHz. For such high-power applications where IGBT is used, you need to have good protection schemes and high driver-side supply voltages to ensure that your design can tolerate the harsh environments in these applications.

One unique parameter of the isolated gate driver is CMTI, which is important to consider when operating the system

at higher switching frequencies. CMTI is the ability of an isolator in the gate driver IC to tolerate high-slew-rate voltage transients between its two grounds without corrupting signals passing through it. The higher the CMTI implies that the isolated gate driver can be used in high-switching frequency applications. Also, with the advent of wide bandgap switches such as gallium nitride (GaN) and silicon carbide (SiC), CMTI is becoming perhaps the most important parameter for isolated gate drivers.

In particular, SiC MOSFET, due to its superior material properties, has emerged as the disruptive solution in power electronics—resulting in energy efficient, robust and compact systems in high-voltage, high-power applications. These applications are increasingly becoming of interest with the advent of electric vehicles and renewable energy power systems—making the gate driver requirements for SiC very critical. TI has a family of isolated gate drivers, UCC217x, with fast, integrated sensing for SiC MOSFETs. Utilizing TI’s capacitive isolation technology, the UCC217x family maximizes insulation barrier lifetimes while providing high reinforced isolation ratings, fast data speeds and high density packaging.

This stems from TI’s capacitive barrier and industry’s highest dielectric strength insulator, SiO<sub>2</sub>. Each capacitive barrier is built using TI proprietary technology with strength exceeding 12.8 kV of isolation surge-voltage protection and a specified isolation voltage of 5.7 kV to ensure strengthened system-level reliability. In addition, fast short-circuit protection and quick response time enhanced system protection.

**Table 2** compares MOSFET and IGBT isolated gate drivers and summarizes the differences explained earlier.

Power Switch	MOSFET	IGBT
Switching frequencies	High (>20 kHz)	Low-to-medium (5 kHz to 20 kHz)
Number of channels	Single-and dual-channels	Single-channel
Protection	No	Yes—Desaturation, Miller clamping
Max V <sub>DD</sub> (power supply)	20 V	30 V
V <sub>DD</sub> range	0 V to 20 V	-10 V to 20 V
Operating V <sub>DD</sub>	10 V to 12 V	12 V to 15 V
UVLO	8 V	12 V
CMTI	50 to 100 V/ns	<50 V/nx
Propagation delay	Smaller the better (<50ns)	High (not critical)
Rail voltage	Up to 650 V	>650 V
Typical applications	Power supplies: server, data communications, telecommunications, factory automation, onboard and offboard chargers, solar μ-inverters and string inverters (<3 kW), 400-V to 12-V DC/DC, automotive	Motor drives (AC machines), UPS, solar central and string power inverters (>3 kW), automotive traction inverters

**Table 2.** Comparison between MOSFET and IGBT isolated gate drivers.

### Summary

High-power density and robustness are becoming increasingly important in power management applications such as power supplies, solar inverters and HEV/EV DC/DC converters. With increasing power levels, it is important to protect HMI and intelligent systems. Therefore, isolated gate drivers are becoming the preferred solutions for these applications. This section compared the value of the isolated gate driver to the traditional transformer method. Key requirements for this driver are highlighted and explained as a function of the power switch and application. TI offers several isolated gate drivers for these power switches. These include isolated gate drivers such as the [UCC21710-Q1](#), [UCC21732-Q1](#), [UCC21750](#), [UCC21520](#), [ISO5451/5452](#), [UCC5350](#) and [UCC21220](#) family for several applications such as power supplies, motor drivers, solar inverters and automotive electrification systems to name a few.

### 2.2.2 Understanding peak source and sink current parameters

Gate drivers are often confused as continuous current sources because of the high-level output current ( $I_{OH}$ ) and low-level output current ( $I_{OL}$ ) specifications in the data sheet. For example, designers looking at TI's [UCC5320SC](#) might read the parameters “4.3-A source” and “4.4-A sink” and mistakenly believe that these devices are capable of providing these currents continuously.

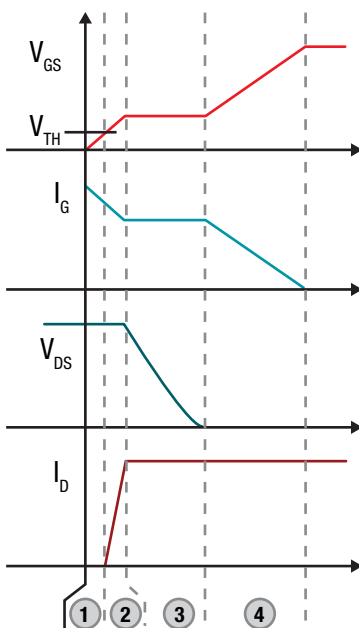

Figure 1. MOSFET turn-on time intervals.

Gate drivers do not need to provide constant current because they only have to source or sink current when switching the gate of power MOSFET or IGBTs.

Figure 1 shows the turn-on waveforms.

Understanding the  $I_{OH}$  and  $I_{OL}$  specifications requires looking at the pull-up and pull-down structures inside the device. The output stage of a gate driver typically comes in some variation of Figure 2. The UCC5320SC is offered in a split-output pinout that gives you more control of the rise and fall times without adding extra components like Schottky diodes.

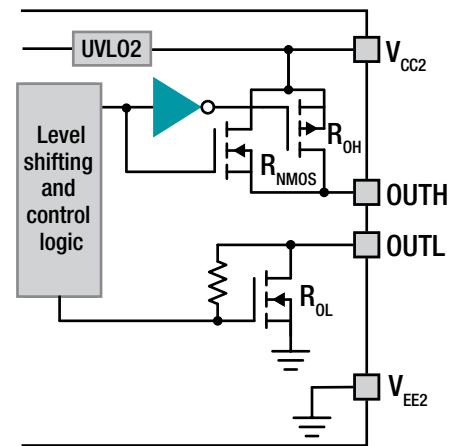

Figure 2. Gate driver output stage.

Under a no-load condition,  $I_{OH}$  is determined by  $V_{CC2}$  and the parallel combination of  $R_{NMOS}$  and  $R_{OH}$ , while  $I_{OL}$  is set by  $V_{CC2}$  and  $R_{OL}$ .  $R_{NMOS}$  helps the pullup structure deliver the peak current, with a brief boost in peak-sourcing current during the Miller plateau region, shown as interval 3 in Figure 1. This is done by turning on the N-channel MOSFET during a narrow instant when the output is changing states from low to high. When driving MOSFETs and IGBTs high, the external gate resistor  $R_{ON}$  and the transistor’s internal gate resistance  $R_{GFET\_Int}$  reduce the peak output current, as shown in Equation 1:

$$I_{OH} = \min \left( 4.3A, \frac{V_{CC2}}{R_{NMOS} || R_{OH} + R_{ON} + R_{GFET\_Int}} \right) \quad (1)$$

Likewise, the peak sink current is limited by the external gate resistor  $R_{OFF}$  in series with  $R_{OL}$  and  $R_{GFET\_Int}$  and is determined by Equation 2

$$I_{OL} = \min \left( 4.4A, \frac{V_{CC2}}{R_{OL} + R_{OFF} + R_{GFET\_Int}} \right) \quad (2)$$

It is possible to demonstrate different techniques to determine the peak drive current using the UCC5320SC isolated single-channel gate driver and a 100-nF capacitive load. The first method calculates the expected peak currents based on Equations 1 and 2. Use these equations to estimate the peak drive current when selecting a gate driver for your system.

In order to simulate driving a MOSFET or IGBT before installing one onto a printed circuit board, select a load capacitor equivalent to the switch's input capacitance,  $C_{ISS}$ . Determine the input capacitance by looking up the required gate charge from the MOSFET or IGBT's data sheet at the drive voltage condition.

A second technique uses  $C_{ISS}$  and the transient voltages ( $dv/dt$ ) of the switching waveform to determine the source or sink current. **Figure 3** measures the  $dv/dt$  using cursors set to a fixed 35-ns interval and swept across the rising edge in order to find the peak  $dv/dt$ . As a guideline, set the oscilloscope's cursors to a time interval,  $\Delta t$ , that is approximately 10% of the rise time to determine the current through the load capacitor.

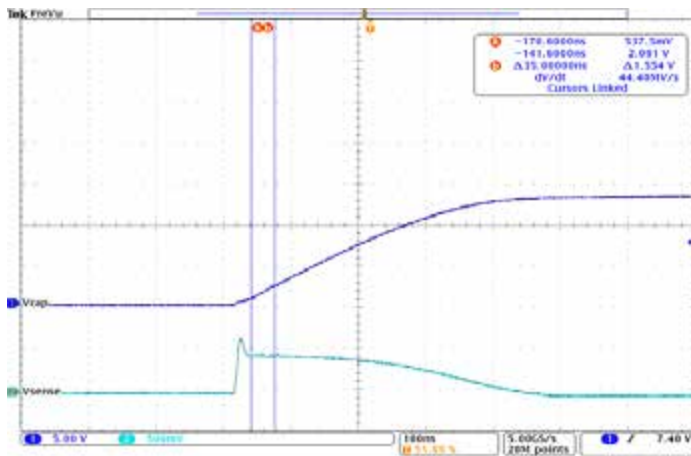
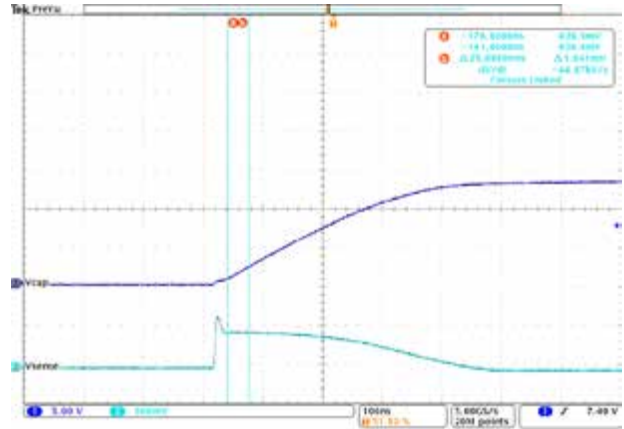

**Figure 3.** Measuring peak  $dv/dt$  across the load capacitor.

Use the measured peak  $dv/dt$  and load capacitor value to calculate the peak current, along with **Equation 3**:

$$I_C = C \frac{dv}{dt} \tag{3}$$

A third method inserts a 0.1- $\Omega$  sense resistor between the capacitor and ground to calculate  $I_{OH}$  or  $I_{OL}$ . **Figure 4** shows the voltage waveform across the sense resistor,  $V_{SENSE}$ , and its measurement coincides with the highest  $dv/dt$  value of the  $V_{cap}$  waveform.



**Figure 4.** Voltage across the series sense resistor.

**Table 1** presents the results of the three techniques. Even with a 0.1- $\Omega$  sense resistor in series with the capacitor, Equation 1 predicts a 4.30-A sourcing current. Equation 3 uses the largest measured  $dv/dt$  value in the linear region of the gate drive waveform, which gives an estimated 4.53 A. In this same linear region, the voltage across the sense resistor is measured in Figure 4, with Ohm's law determining peak  $I_{OH}$  at 4.29 A.

Theoretical vs. measured	Method	Result
Theoretical	Equation 1: $I_{OH} = \min(4.30 \text{ A}, 4.44 \text{ A})$	4.30 A
Calculated from measurement	Equation 3: $I_C = 102 \text{ nF}(4.44 \text{ MV/s})$	4.53 A
Calculated from measurement	Ohm's Law: $I_{OH} = 438 \text{ mV}/102 \text{ m}\Omega$	4.29 A

**Table 1.** Measurement comparison.

The first method is a good starting point when selecting a gate driver, but what you will obtain is not an actual measured value. The second method relies on an accurate measurement of the highest  $dv/dt$  by using a fixed  $\Delta t$  and sweeping it across the waveform. Finally, the voltage measured across the 0.1- $\Omega$  sense resistor will give you a value calculated from the measurement of the peak drive current using Figure 4 and Ohm's law. The key to the third measurement technique is to select a small-valued sense resistor to prevent any limitations in the peak output current. All presented methods are acceptable approximations of a gate driver's peak output current.

To reiterate,  $I_{OH}$  and  $I_{OL}$  are not continuous DC values. The peak current charges or discharges  $C_{ISS}$  in an instant and then reduces in value as the switch begins to turn on.

### 2.2.3 Low-side gate drivers with UVLO versus BJT totem poles

Gate drivers have increasingly replaced the use of bipolar junction transistor (BJT) totem poles to drive power switches in low-side applications. Gate drivers come with many built-in safety features, eliminating risks associated with the lack of protection in a discrete solution. When driving MOSFETs and IGBTs, safety features are important in ensuring a predictable switching, robust gate drive. Let's compare the UCC27517 gate driver and a discrete totem pole, looking at their respective performances during undervoltage lockout (UVLO) conditions.

#### The importance of UVLO

The UCC27517 gate driver has an important built-in protection feature that grounds the output of the driver when the power supply has not reached the UVLO threshold.

**Figure 1** shows how different values of  $V_{GS}$  affect the MOSFET for a given drain-to-source voltage. The right side of the red curve is the saturation region, defined by a constant drain-to-source current, dependent on the gate-to-source voltage and independent of the drain-to-source voltage. This saturation region is where power losses can be high, due to a simultaneous presence of high drain current and high drain-to-source voltage. The left side of the red curve is the linear region, where the drain current is proportional to the low  $R_{DS(on)}$  of the MOSFET. For applications with a high drain current, a drop in the gate-to-source voltage can be dangerous for the MOSFET. The UCC27517, as well as other low-side drivers in the UCC family, prevent that drop with their built-in UVLO, enabling safe power up.

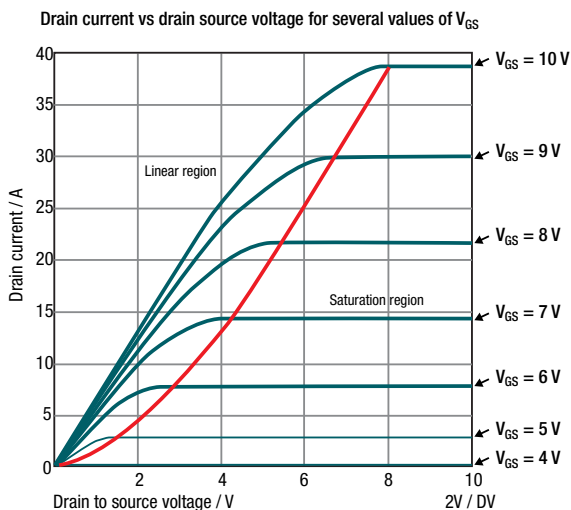

Figure 1. MOSFET 1 to 5 characteristics.

#### Why a BJT totem pole offers no protection

**Figure 2** shows a BJT totem-pole configuration to drive the MOSFET. Figure 2 shows a typical gate-drive circuit achieved using a bypass capacitor and an additional base resistance to limit the input current. At power on and power off, before the BJT drive supply settles, the MOSFET can be subject to a combination of high voltage and high current. You could add external UVLO circuitry to this circuit, but this addition results in an increase in component count, board footprint and bill-of-materials (BOM) cost.

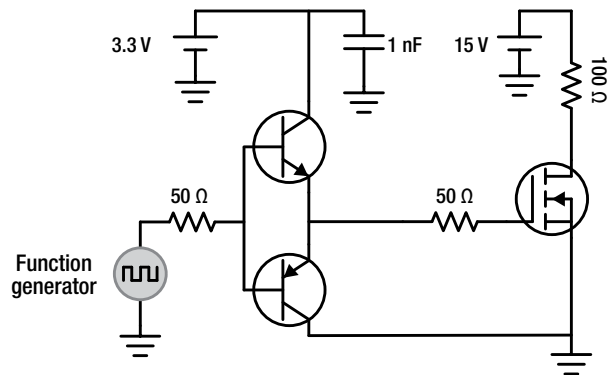

Figure 2. BJT totem-pole schematic.

**Figure 3** shows the UCC27517 device driving the power switch in the same conditions but with a built-in UVLO, which is typically 4.2 V with 300-mV typical hysteresis. When the supply voltage reaches UVLO, the output of the driver rises with  $V_{DD}$  until it reaches steady state. This solution also uses fewer components, has a lower footprint and saves BOM cost.

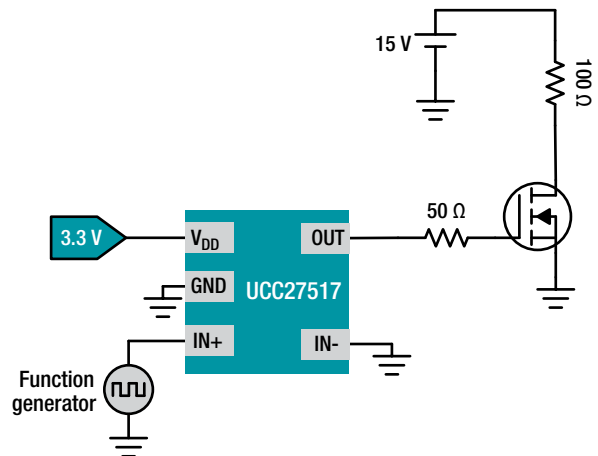
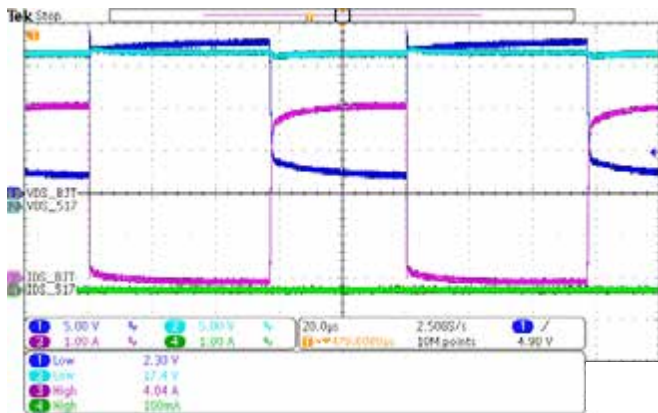

Figure 3. UCC27517 schematic.



## Protecting the MOSFET and IGBT using the UCC27517 with UVLO

At a 3.3-V startup, there is a significant difference in the thermal behavior of both gate drives. The UCC27517 gate driver clamps its output, preventing switching as well as the drain-to-source voltage drop across the field-effect transistor (FET) at its output. The waveforms in **Figure 4** illustrate this event. Channel 2, VDS\_517, captures no voltage drop across the MOSFET, while channel 4, IDS\_517, shows the drain current grounded during power up. This process occurs until the supply voltage reaches the UVLO rising threshold. However, the BJT allows a voltage drop across the MOSFET captured by channel 1, VDS\_BJT, while the drain current rises significantly, as shown by channel 3, IDS\_BJT. This rise in current leads to excessive power dissipation and can potentially damage the MOSFET.



**Figure 4.** Waveforms of the UCC27517 and BJT totem-pole gate drives at a 3.3-V power up.

**Figure 5** shows a thermal image of this event. On the left, the UCC27517 driving the MOSFET (with its built-in UVLO) prevents overheating at the FET junctions by grounding its output. The driver's output stays grounded regardless of its input during UVLO conditions. On the right, however, the FET at the BJT totem-pole output, with no protection, is exposed to overheating due to increased power dissipation.

UVLO is an important feature, allowing smooth power up and power down of the MOSFET by ensuring that switching only occurs when enough voltage is supplied. The UCC27517 takes care of this issue with its internal UVLO by grounding its output and thereby preventing overheating of the MOSFET. This feature is essential, because this excessive power dissipation at the MOSFET junctions can occur during power up and power off and potentially damage the FET.

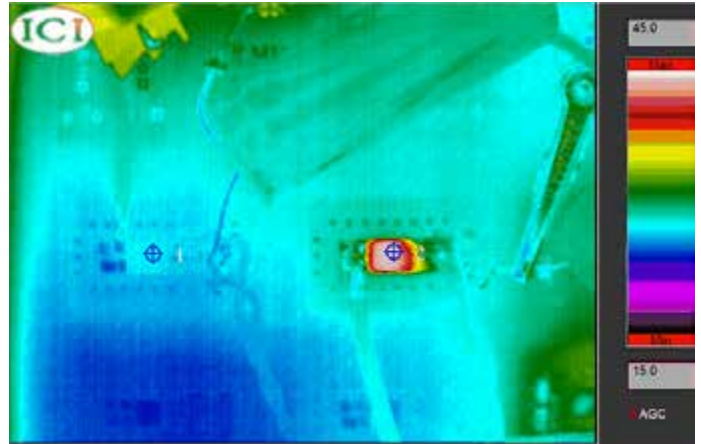

**Figure 5.** Thermal image of the UCC27517-driven MOSFET (left) and BJT-driven MOSFET (right) at a 3.3-V power up.

Internal UVLO protection is not limited to the UCC27517 gate driver; it also extends to other devices in the UCC family of low-side gate drivers.

### 2.2.4 An external gate-resistor design guide for gate drivers

External gate-drive resistors play a crucial part in limiting noise and ringing in the gate-drive path. Parasitic inductances and capacitances, high transient voltages (dv/dt) and transient currents (di/dt), and body-diode reverse recovery can cause unwanted behavior without an appropriately sized gate resistor.

**Figure 1** depicts common elements in the gate-drive path: the internal resistance of the gate driver, external gate resistance and internal gate resistance of the MOSFET or IGBT.  $R_{GATE}$  is the only component that tunes the gate-drive waveform.

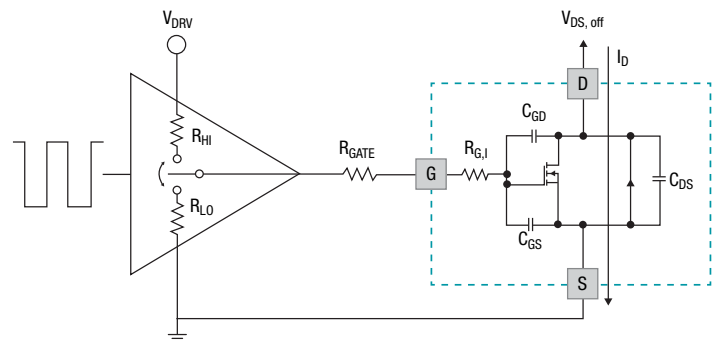

**Figure 1.** Gate-drive elements.



**Figure 2** shows the parasitic inductances and their effect on the gate drive waveform created by long trace length and poor PCB design.

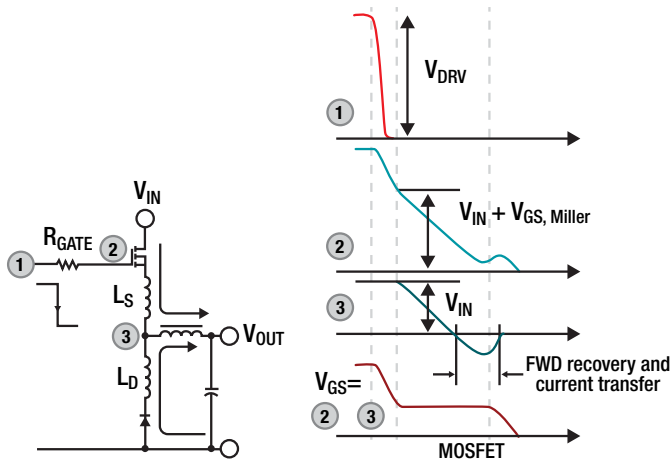

**Figure 2.** Switching theory.

Parasitic inductance and capacitance cause oscillations in the gate-drive loop and are modeled by resonant circuits. Fortunately, it is possible to damp the otherwise very high Q resonance between the input capacitance,  $C_{ISS}$  ( $C_{GD} + C_{GS}$ ), and the source inductance,  $L_S$ , by the series resistive components of the loop,  $R_G$  ( $R_G = R_{HI} \text{ or } L_O + R_{GATE} + R_{G,i}$ ).

An optimal gate-resistor selection is key for a high-performance design. Without optimization, small resistor values will result in overshoot in the gate-drive voltage waveform and also result in a faster turn-on speed. Higher resistor values will also overdamp the oscillation and extend the switching times without offering much benefit for the gate-drive design.

It's best to select a gate resistor that will give your design a quality factor Q between 0.5 (critically damped) and 1 (underdamped). A quality factor greater than 0.5 will give you faster turn-on and turn-off if required.

Start by recording the gate-drive ring with no external resistance. This is your ring frequency,  $f_R$ , used in **Equation 1**:

$$L_S = \frac{1}{CISS(2\pi f_R)^2} \quad (1)$$

The MOSFET or IGBT data sheet will provide  $C_{ISS}$ , which will help you calculate  $L_S$ .

Determine when  $R_G$  is equal to or twice the inductor's reactance for underdamped or critically damped performance. Subtracting the internal gate drive and

transistor gate resistance from the total series resistance then determines the external gate resistor, as expressed by **Equation 2**:

$$Q = \frac{X_L}{R_G} = \frac{\omega L_S}{R_G} \quad (2)$$

The method described here is an iterative process starting with  $0 \Omega$  as the external gate resistance and calculating a new external gate-resistor value based on the ring frequency, source inductance and input capacitance.

Two isolated single-channel gate drivers in a half-bridge configuration provide proof of concept. Two UCC5310MC gate drivers driven from a 15-V supply drive two 100-V CSD19536KCS MOSFETs with a typical internal gate resistance,  $R_{G,i}$ , of  $1.4 \Omega$ .

The CSD19536KCS MOSFET's relatively small internal gate resistance shows the effects of adding external gate resistors. External gate resistors may not be required if a MOSFET's or IGBT's internal gate resistance is large enough.

At  $0 \Omega$ , there is unwanted ringing on the gate-source waveform. The internal gate resistance of the CSD19536KCS MOSFET is not enough to dampen the oscillations found in

**Figure 3.**

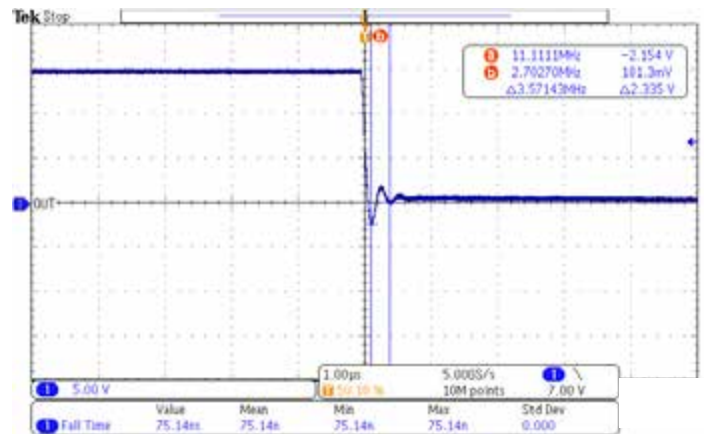

**Figure 3.** External gate resistor where  $R_{GATE} = 0 \Omega$ .

Using 3.57 MHz as the ring frequency and 9,250 pF as the input capacitance, Equations 1 and 2 can determine a critically damped resistor value. Don't forget to subtract the series resistive elements  $R_{G,i}$  and  $R_{HI}$  or  $L_O$  from this calculated value. **Figure 4** (next page) demonstrates the effects of adding a  $7\text{-}\Omega$  resistor to the gate-drive path, which makes the waveform critically damped.

The selection of external gate resistor will affect three things: drive current, gate-driver power dissipation, and rise and fall times. Figures 3 and 4 show the gate resistor’s dampening effect and its effect on rise and fall times.

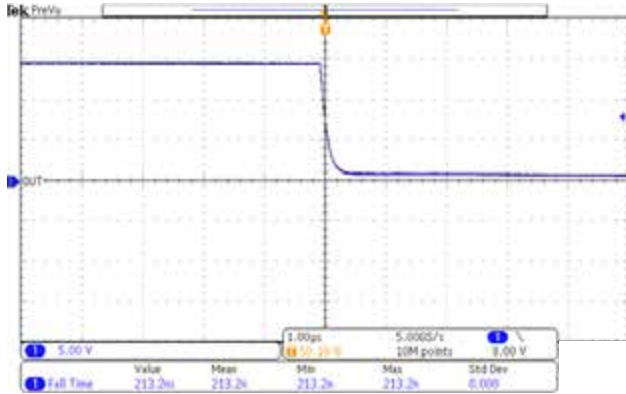

**Figure 4.** A critically damped external gate resistor where  $R_{GATE} = 7 \Omega$ .

If the rise and fall times are too slow after adding an optimized gate resistor, another option is to calculate your gate resistor with a Q factor set to 1. This will promote an underdamped solution, but be careful to prevent overshoot or undershoot. If you still see overshoot or undershoot conditions, look at the source and sink current of your gate driver and find a device with greater peak currents to replace it with. This will charge and discharge your FET at a faster rate, but you will need a new optimized gate resistor to prevent overshooting.

For alternate device recommendations, see **Table 1**.

Device	Optimized parameters	Performance trade-off
UCC5350MC	Miller clamp feature available	Requires larger value gate resistor due to higher source/sink current
UCC5320SC	Split output feature available	Need to design a method to prevent Miller current induced turn-on
UCC5390EC	UVLO2 referenced to GND2 feature available	True UVLO2 monitoring at the expense of not having split output or Miller clamp
UCC21220	Configured as a half-bridge or two low-side drivers	Difficult to layout both transistors close to each output when using a dual channel

**Table 1.** Alternate device recommendations.

Another way to decrease ringing from the series  $R_{LC}$  circuit shown in **Figure 5** is to minimize the loop inductance between the source of the high-side transistor and the source of the low-side transistor. Confining the high peak currents that charge and discharge the transistor gates to a minimum physical area is essential. You must place the gate driver as close as possible to the transistors to reduce parasitics.

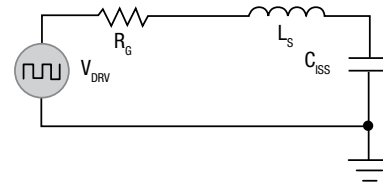

**Figure 5.** Resonant circuits in a gate-drive design.

The trade-off between fast rise and fall times versus oscillations is why the external gate-resistor element of a gate-drive design is so valuable.

### 2.2.5 High-side motor current monitoring for overcurrent protection

High-power precision motor systems commonly require detailed feedback such as speed, torque and position. Sending this feedback to the motor-control circuitry helps control the motor’s operation to be more precise and efficient. Other motor-control applications such as fixed-motion tasks do not require the same level of system complexity in order to carry out their jobs. Ensuring that the motor has not stalled or encountered an unintended object in the motor’s path, or that a short in the motor’s winding exists may be all of the feedback that’s necessary. More complex motor-control systems implementing dynamic control and active monitoring can benefit from adding a simple out-of-range detection function because of the faster indication of out-of-range events.

Placing a current-sense amplifier in series with the DC power supply driving the high side of motor-drive circuitry, as shown in **Figure 1**, enables the measurement of overall current to the motor and the detection of out-of-range conditions. To detect small leakages, it is also possible to measure the low-side return current. A difference between the high- and low-side current levels indicates that a leakage path exists within the motor or motor-control circuitry.

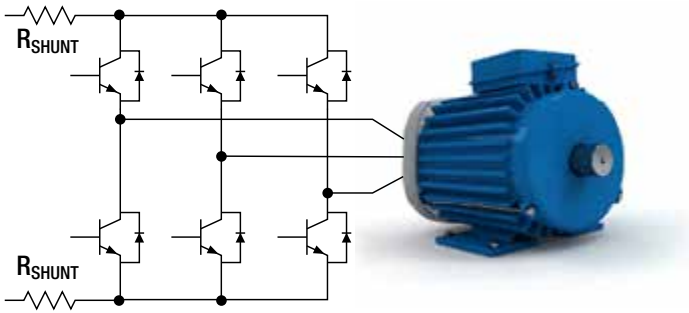

**Figure 1.** Low- and high-side current sensing.

The DC voltage level varies depending on the motor's voltage rating, leading to multiple current-measurement solutions to accommodate the corresponding voltage levels. For low-voltage motors (~5 V), the selection of circuitry to monitor this current is simple: multiple amplifier types (current sense, operational, difference, instrumentation) can perform the current-measurement function to support a common-mode input voltage range.

For higher-voltage motors (24 V and 48 V), the only available options are dedicated current-sense and differential amplifiers. As the voltage requirements continue to increase, measurement errors will begin to impact the ability to effectively identify out-of-range conditions. One specification that describes an amplifier's effectiveness at operating at high input voltage levels is common-mode rejection. This specification directly describes how well an amplifier's input circuitry can reject the influence of large input voltages.

Under the best conditions, an amplifier can completely reject and cancel out any voltage common to both input pins and amplify only the differential voltage between them. As the common-mode voltage increases, however, leakage currents in the amplifier's input stage result in an additional input offset voltage. Monitoring larger input range levels will create proportionally larger measurement errors.

For example, an difference amplifier or current-sense amplifier that has a common-mode rejection specification of 80 dB will have a significant offset voltage introduced in the measurement based on the input voltage level. An 80-dB common-mode rejection specification corresponds to an additional 100  $\mu\text{V}$  of offset voltage induced into the measurement for every volt applied to the input.

Many devices are specified under defined conditions (such as  $V_{\text{CM}} = 12 \text{ V}$  and  $V_{\text{S}} = 5 \text{ V}$ ) which establishes the baseline for the default common-mode rejection and power-supply rejection ratio specifications. In this example, operating at a 60-V common-mode voltage creates a change in  $V_{\text{CM}}$  of 48 V (60 V to 12 V). A 48-V change with a 80-dB of common-mode rejection results in an additional 4.8 mV of offset voltage – in addition to the specified input offset voltage found in the device's data sheet.

Applications employing calibration schemes are less concerned by this additional induced offset voltage. However, for applications where system calibration cannot account for this shift in offset, you must select an amplifier with better common-mode voltage rejection.

The [INA240](#) is a dedicated current-sense amplifier with a common-mode input voltage range of -4 V to +80 V and a worst case common-mode rejection specification of 120 dB over the entire input and temperature range of the device. A common-mode rejection of 120 dB corresponds to an additional 1  $\mu\text{V}$  of input offset voltage induced for every 1-V change in common-mode voltage. The temperature influence on the amplifier's ability to reject common-mode voltages is not well documented in many product data sheets, so you should evaluate it in addition to the room temperature specification. The INA240 maintains a guaranteed 120-dB common-mode rejection specification over the entire -40°C to +125°C temperature range. **Figure 2** shows that the typical common-mode rejection performance for the INA240 over the entire temperature range is 135 dB (less than 0.2  $\mu\text{V}$  for every 1-V change).

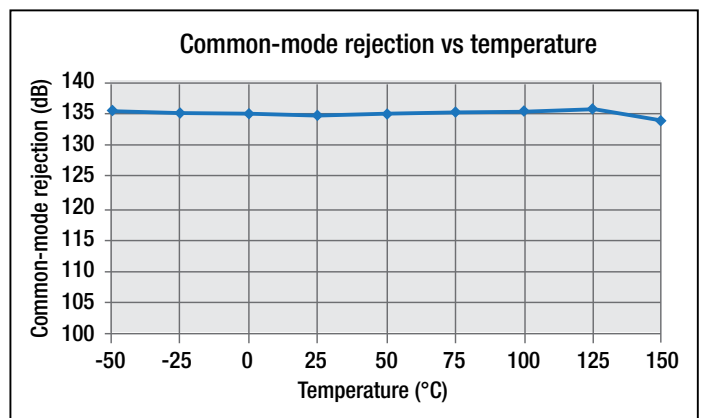

**Figure 2.** Common-mode rejection vs. temperature.

A system controller has the ability to use the current-sense amplifier's measurement to evaluate overall system operation. Comparing the current information to a predefined operating threshold enables the detection of out-of-range events. A comparator following the high-side current-sense amplifier can easily detect and provide alerts quickly to the system, enabling corrective actions.

**Figure 3** illustrates the signal-chain path for monitoring and detecting out-of-range excursions when measuring currents on a high-voltage rail driving the motor-drive circuitry. The output signal proportional to the measured input current is directed to the analog-to-digital converter; the output signal is also sent to the comparator to detect overcurrent events. The comparator alert will assert if the input current level exceeds the predefined threshold connected as the comparator's reference voltage.

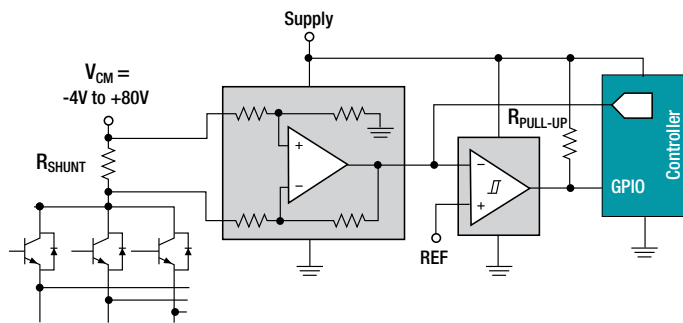

**Figure 3.** High-side overcurrent detection.

A key requirement for overcurrent detection circuitry is the ability to detect and respond quickly to out-of-range conditions. A signal bandwidth of 100 kHz and 2 V/μs enables the INA240 to accurately measure and amplify the input current signal and send the output to the high-speed comparator, which can issue an alert in the event of a shorted condition in just a few microseconds. This fast response ensures that other critical system components will not be damaged by unintended excess current flowing in the system.

### Alternate device recommendations

For applications measuring high voltage that need a faster signal bandwidth or a smaller package, consider the LMP8640. For applications requiring higher-voltage

capability, the INA149 is a high-performance difference amplifier capable of interfacing with common-mode voltages up to ±275 V off of a ±15-V supply and has a guaranteed common-mode rejection of 90 dB (or 31.6 μV for every 1-V input change).

**Table 1** summarizes these alternate device recommendations.

Device	Optimized parameter	Performance trade-off
<a href="#">LMP8640HV</a>	Package: SOT23-6, signal bandwidth	Accuracy
Calculated from measurement	$V_{CM}$ Range: ±275V	CMR, Gain
Calculated from measurement	Onboard comparator; 35μV $V_{OS}$	$V_{CM}$ : 0V to 36V

**Table 1.** Alternate device recommendations.

The INA301 is a precision current-sense amplifier with an onboard comparator that can detect overcurrent events on common-mode voltages up to 36 V.

## 2.2.6 Five benefits of enhanced PWM rejection for in-line motor control

There's almost always more than one way to solve a problem. Sometimes the most widely used method doesn't yield the biggest benefit. System designers working on motor-control projects use various current-measurement methods to ensure that motors are running efficiently, and to prevent possible damage.

As **Figure 1** depicts, there are three different ways to measure current in three-phase motor-drive systems: low-side, DC link and inline. While Figure 1 shows the traditional three-phase pulse-width modulation (PWM) inverter needed to drive a DC motor with the three pairs of power MOSFETs (IGBTs are very common as well), Figure 1 also includes high-side current sensing, which is typically used for gross fault conditions such as a short to ground.

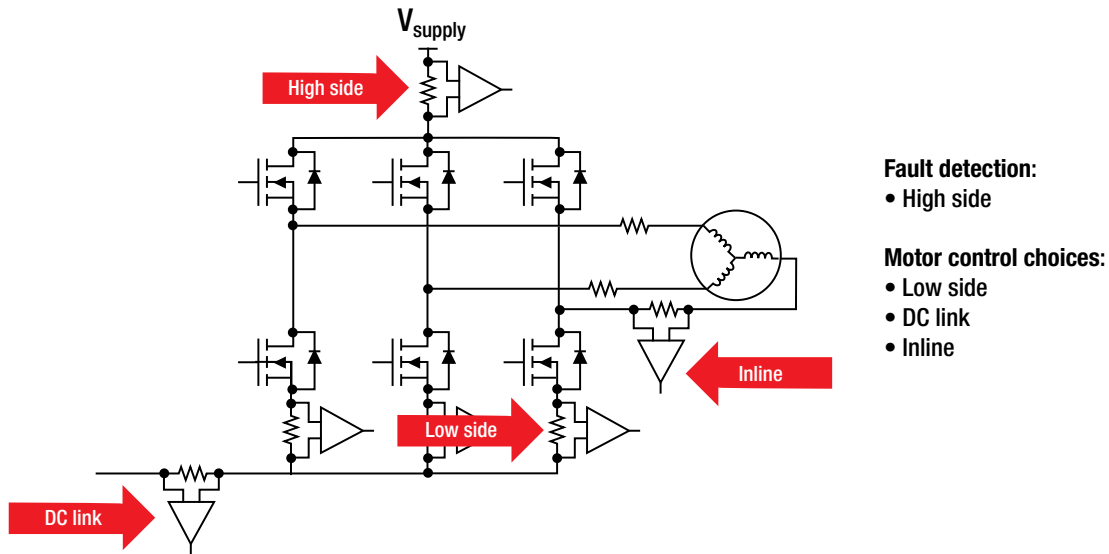

**Figure 1.** Various current-sensing methods for three-phase motor-drive systems.

Many designers use the first two methods (low side, DC link and various combinations thereof) because standard current-sensing solutions are readily available – typically with fast response times, high bandwidths, fast output slew rates and low common-mode input voltages. But just because products exist that can sense phase current via low side or DC link doesn't mean that these solutions represent the easiest way. The idea behind measuring current is to try to replicate the current being driven into the motor windings. This replication effort occurs in software; it can be quite involved and is never truly exact.

The inline current-sensing method seems to be the most logical because that is the current you are ultimately trying to measure, but there is a challenge associated with this approach. The PWM signals driving the MOSFETs or IGBTs wreak havoc on the current-sense amplifier. The common-mode signals at the sense resistor are driven from the supply voltage to ground with very fast transient switching characteristics, while the current-sense amplifier is trying to measure a small differential signal across the sense resistor itself.

**Figure 2** is an oscilloscope shot of the sinusoidal phase current (red waveform) generated by the PWM inverter. In this case, the PWM frequency is 100 kHz, sourced by the [LMG5200](#) gallium nitride half-bridge power stage. The fast switching signals are what the inline current-sense amplifier experiences as it measures the phase current.

If I could use an analogy, this is like trying to measure the liquid in a cup as it floats along the sea during a hurricane. No wonder most designers use low-side sensing!

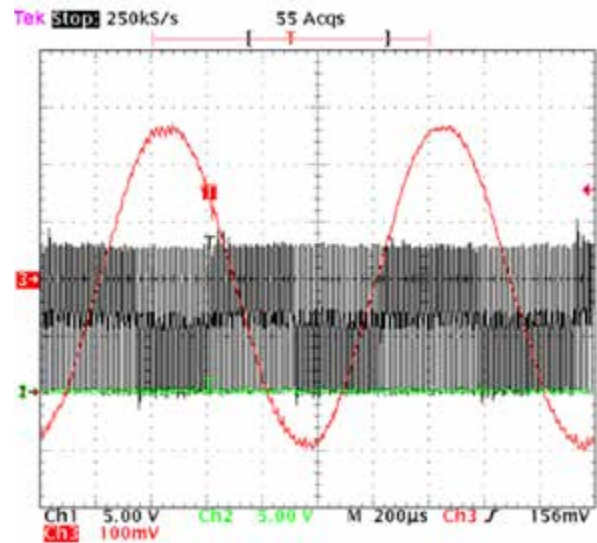

**Figure 2.** Measuring phase current amid fast common-mode transients.

Before describing the potential benefits of inline motor current sensing using enhanced PWM rejection, let me explain enhanced PWM rejection. Enhanced PWM rejection is active circuitry that forces the output voltage to settle much more quickly than traditional methods. As the current-sense amplifier detects input common-mode signals with fast transitions, internal active circuitry minimizes disturbances that may propagate to the device's output.



An alternate method to reduce these disturbances, also known as ringing, is to use high-bandwidth amplifiers (in the megahertz range) to settle the output as quickly as possible, but that may be an expensive proposition.

**Figure 3** shows the output voltage signal for each of the phases represented without the introduction of noise. The red waveform is a representation of the signal to show that the power transistors, which are electronically commutated, replicate a sinusoidal waveform to the motor as closely as possible. The current-sense amplifier will experience an input common-mode voltage signal from the power-supply rail ( $V_{BATT} = 48\text{ V}$ , for example) to ground.

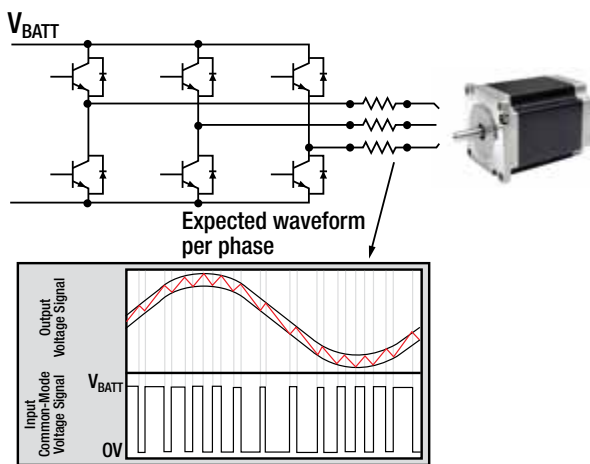

**Figure 3.** Expected voltage waveform with enhanced PWM rejection.

Five core benefits of in-line motor current sensing using enhanced PWM rejection include:

- **Reduced blanking time.** Common-mode PWM transient suppression reduces ringing at the output of the current-sense amplifier. Having to wait for the voltage signal to settle is a major drawback, especially for systems that require low duty cycles ( $\leq 10\%$ ) because the time to take the current measurement is shortened (commonly known in the industry as blanking time).
- **In-line current sensing.** Coupled with a high common-mode input voltage, enhanced PWM rejection facilitates the ability to monitor current inline. The robustness of a current-sense amplifier is a necessity due to the harsh environment to which it's exposed. Aside from this requirement, the amplifier must also have high AC and DC accuracy to provide precise current-sensor measurements.
- **The possible elimination of galvanic isolation.** Another benefit of enhanced PWM rejection is subtle but important. With enhanced PWM rejection, you may be able to eliminate the use of an isolated current-sensing device when galvanic isolation is not part of the system requirements. Isolated devices will decouple the noise generated as the PWM signals travel through the sense resistor. This decoupling is no longer necessary with enhanced PWM rejection.
- **Algorithm optimization.** With enhanced PWM rejection, the need to replicate or calculate the phase current is no longer an issue because the answer is already provided directly. Only minimal software is required to run the motor efficiently.
- **Increased motor efficiency.** Motor manufacturers and motor-drive system designers are always looking for ways to improve motor efficiency. High AC and DC accuracy, a fast output response and reduced blanking time enable motor operation at the highest efficiency possible. Precise timing control of a multiphase motor reduces the blanking time as much as possible, which in turn maximizes motor efficiency.

The [INA240](#) current-sense amplifier from TI incorporates enhanced PWM rejection, which brings with it many system-level benefits to your motor design.

## 2.2.7 How to protect control systems from thermal damage

In many control systems, the operating temperature is one of many factors that can affect the system's performance, reliability and safety. Understanding the temperature effects on control systems can help system designers anticipate and prevent thermal damage.

Typically, control systems operate within limited temperature ranges. But whenever the system operates beyond its specified temperature range, its behavior becomes unpredictable. When operating at high temperatures, the control system typically experiences a decrease in efficiency, an increase in heat dissipation and accelerated aging. On the other hand, temperatures that are too low can also have a negative impact on the system's safety and function, as the operating condition experiences effects such as condensation. The combination of these effects may lead to costly failures.



A number of discrete or integrated solutions exist that are designed to protect control systems from thermal damage. Generally, these solutions comprise a temperature sensor, a comparator and a voltage reference (see **Figure 1**).

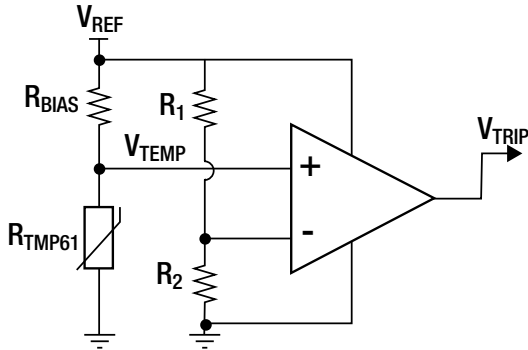

**Figure 1.** Thermistor + comparator for threshold detection.

This approach provides real-time thermal protection without interrupting the control processing system. **Figure 2** shows an example of temperature switch behavior. In this example, the trip point is set to 60°C with a 10°C hysteresis.

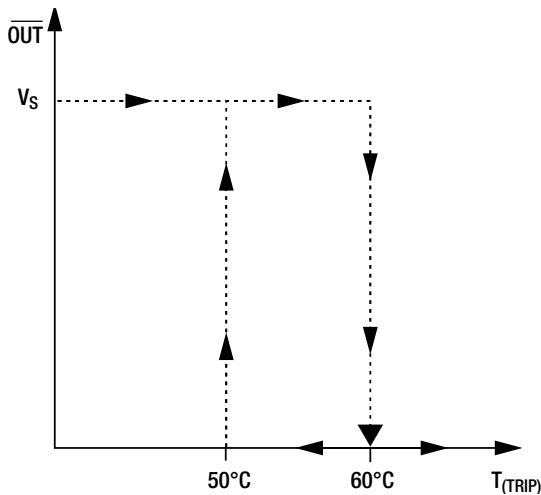

**Figure 2.** Example of temperature switch trip behavior with hysteresis.

Some applications require both thermal protection and monitor functions, and thus you will also need an analog-to-digital converter (see **Figure 3**).

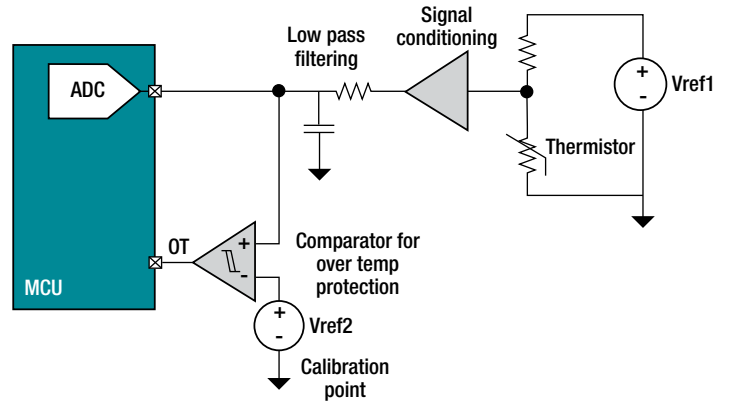

**Figure 3.** Example discrete implementation of a temperature monitor and switch.

The specific implementation will depend on these application requirements:

- Features.
- Cost.
- Footprint.
- Power.
- Accuracy.

Other features to look for include hysteresis, trip-point programmability, trip test, qualifications (like automotive or Underwriters Laboratories), output type, channel count and supply voltage range.

### Discrete solutions

It is quite common to see a discrete implementation of a temperature switch using a negative temperature coefficient (NTC) thermistor, because the use of these devices is well established. Thermistor solutions are also considered low cost. Given the demanding requirements of thermal protection (like guaranteed performance), discrete solutions often prove to be challenging and costly.

Some of the challenges when designing a discrete thermal protection solution include accuracy, reliability and efficiency. For example:

- Because of the nonlinear nature of NTC thermistors, maintaining a high-accuracy trip point at high or low temperatures is difficult without using precision components, which can increase system cost.
- Calibration is not practical in hardware-based switching applications.

- A discrete implementation requires multiple components working together, which can decrease system reliability.
- NTC discrete solutions dissipate a significant amount of power when hot because the NTC resistance decreases significantly at high temperatures.

**Integrated circuit solutions: temperature switches/thermostats**

Another thermal protection solution for control systems is an integrated temperature switch/thermostat. Typically, these devices have a temperature sensor, comparator and voltage reference fully integrated in a single chip. These temperature switches are smart sensors that autonomously make decisions to provide real-time thermal protection without interrupting the control processing system. The key advantages of these sensors are:

- The ability to autonomously enable thermal protection independent of the control unit.
- No software needed.
- Guaranteed temperature accuracy for trip point with hysteresis.
- Simple and cost-effective over- and/or under-temperature detection.

- Various threshold programming options (resistor, pin programmable, factory preset).
- Some devices also offer analog output.

A highly integrated sensor lowers solution costs and enables redundancy in safety applications.

TI provides a broad portfolio of temperature switches and thermistors such as the [TMP302](#), TMP390 and TMP61, shown in **Figure 4**. The TMP302 is available in a small-outline transistor-563 package (1.6 mm by 1.2 mm). The device offers low power (15- $\mu$ A maximum) and ease of use through pin-selectable trip points and hysteresis. The TMP302 can achieve a trip-point accuracy of  $\pm 2^{\circ}\text{C}$  from  $-40^{\circ}\text{C}$  to  $125^{\circ}\text{C}$  without any calibration.

**Design tips**

The TMP302 measures the temperature of the device leads. Careful PCB layout considerations are essential to accurately measure ambient or board temperatures. As with any physical board design, environmental factors can significantly affect system performance. To avoid leakage and corrosion, the system must be kept insulated and dry. This is especially true if the system operates in cold temperatures where condensation can occur. Printed circuit coatings can help ensure that moisture will not corrode the sensor or its connections.

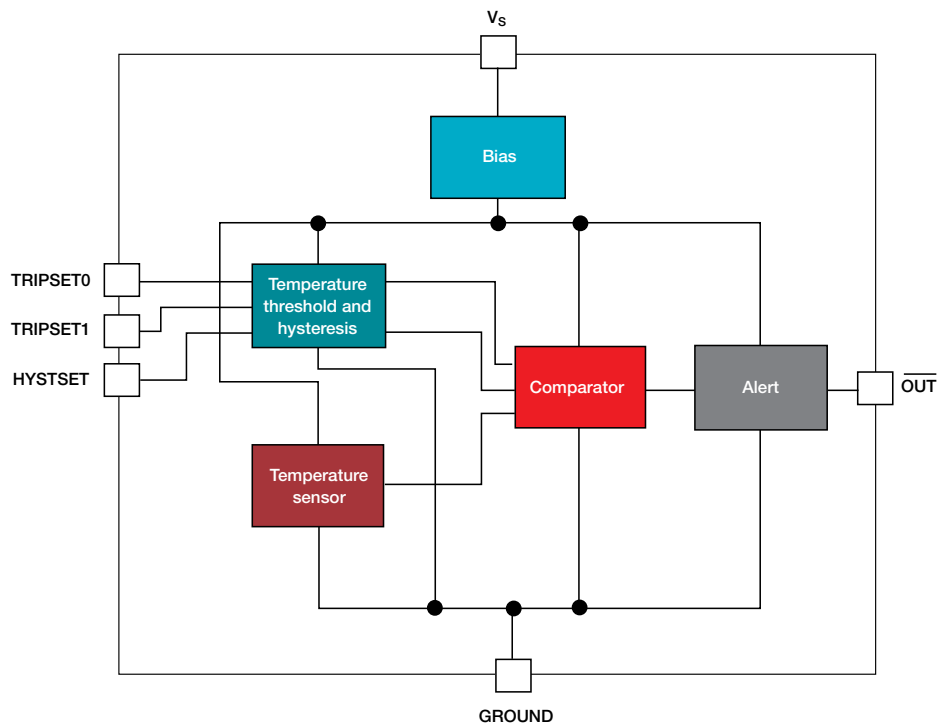

**Figure 4.** Pin-programmable IC temperature switch block diagram.

## 2.2.8 How high precision in motor-drive control enables industrial advances

Picture a robot in an automotive manufacturing plant. It picks up an engine block, moves it to a car chassis, places the block exactly, releases it and returns to its original position to repeat the process. The robot can lift much greater weight than humans, move items to specific spots more consistently and repeat the same operation without stopping – 24 hours a day if necessary.

Robots like these have become a mainstay of manufacturing for automobiles and many other industries, and their use is ever-increasing. But robotics would be impossible to operate without precise motor-drive control. At each point in its operation, a multiaxis robot has to employ different amounts of force in three dimensions in order to move the engine. Motors inside the robot supply variable speed and torque (rotational force) at precise points, which the robot's controller uses to coordinate motion along different axes for exact positioning. After the robot releases the car engine, the motors scale back the torque while returning the arm to its initial position.

Just as the control of motor drives enables advances in robotics and other areas, motor control itself depends on advances in electronics that make precise control possible during real-time operation. High-end power supplies, intelligent motor drivers, high-performance control signal processing and exact sensing feedback all function together to deliver the precise speed and torque that complex machines need instantaneously. The result is greater functionality, higher productivity and increased safety for both equipment and people.

TI offers a range of integrated solutions that enable the development of advanced motor-control systems. TI provides design engineers with integrated circuit (IC) products, including software and tools, that enable them to develop the increasingly precise motor-drive control that industries require. Based on years of engagement with leading motor manufacturers, TI helps engineers simplify the design of motor-control systems while enhancing the performance of their products.

## Benefits of motor control

Controlling motor drives electronically introduces a level of precision that leads to lower costs, greater productivity and new manufacturing capabilities. Drive control ensures a stable rotor position relative to the shunts, so that motor output is more predictable and power usage more efficient. When the load changes on a motor, electronic control can instantaneously modify the voltage input and torque delivered, thus matching the machine's output force and power consumption more closely to the application.

Electronic input control also makes it possible to change drive speeds within the motor itself instead of relying on expensive gears, belts and pulleys to output different speeds. Control enables stepper motors to move rotor positions in the small increments or microsteps required for robotic motion control. For all of these reasons, efficient operation enables applications to use controlled motors that are better scaled for the job, eliminating much of the overhead that would be otherwise required.

Operational efficiency goes hand in hand with increased productivity. For instance, a conveyor belt on an assembly line usually operates in tandem with other systems that load items on the belt, perform operations on items, or receive items from the belt to perform further steps. Belts usually move with a consistent forward motion, but operation may sometimes require changing speeds, stopping or briefly reversing direction. These motions, together with continual changes of the number and weight of items on the belt, require controlled motor drives that can adjust the output automatically. Coordination among motors may be required as well, since multiple belts in a factory are often synchronized in order to keep items moving at an optimal rate. Controlled motors that keep belts moving predictably in changing conditions not only have a positive impact on the productivity of the entire plant, but play an essential role in a contemporary manufacturing environment.

Precisely controlled motors also enable new manufacturing capabilities. Robots offer the most striking example, where electronically controlled motors provide fine-grade control of motion, often combined with strength and speed that go beyond those of humans. While the earlier example of

a robot moving an engine block illustrates strength, other examples emphasize precision or speed of movement. Pick-and-place robots, for instance, repetitively perform fine motion control with tolerances measurable in micrometers, and usually far more rapidly than a human.

By helping remove human workers from high-speed, repetitive, sometimes dangerous tasks, electronically controlled motors make work environments safer. A new development within this trend is occurring today, as robots are being designed to operate safely in collaboration with human workers. While safety issues are often related to system operations and employee procedures, they also include the internal control electronics, which have to protect both equipment and workers from electrical discharges. Safety is always an important element in the design of industrial machines and the motors that run them.

### Design challenges for precise motor control

Many types of motors are used for specific tasks, but the majority of industrial motors run on three-phase power from an AC electrical supply. **Figure 1** shows a block diagram of the representative control electronics for such a system. AC power input is rectified to DC. A pulse-width modulation (PWM) switched three-phase inverter creates three high-frequency pulsed voltage waveforms that it outputs in separate phases to the three phase windings of the motor.

In these three power signals, changes in the motor load impact the current feedback that is sensed, digitized and sent to a digital processing unit (like microcontrollers [MCUs], microprocessors [MPUs], processors or field-programmable gate arrays [FPGAs]). High-speed digital signal processing algorithms in the digital processing unit determine in real time whether changing conditions make it necessary to adjust the power being delivered. The processing unit sends a control output with PWM to the three-phase inverter in order to gate power switching and regulate the power outputs to the windings, thus supplying greater or lesser torque or speed from the motor. Additional sensing data may be fed into the controller to track system input voltage and temperature changes.

All of these components require a high level of performance for precise motor control. The switched-mode power supply (SMPS) to supply the control system must be capable of ultra-high-speed switching, controlled with consistently high resolution. Power-supply design is exacting because of the high voltages and frequencies involved and numerous passive components required, which introduce mutually reactive impedances that are difficult to manage. Fortunately, new high-frequency materials and integrated SMPS modules are making it much easier to design high-performance power supplies in control systems.

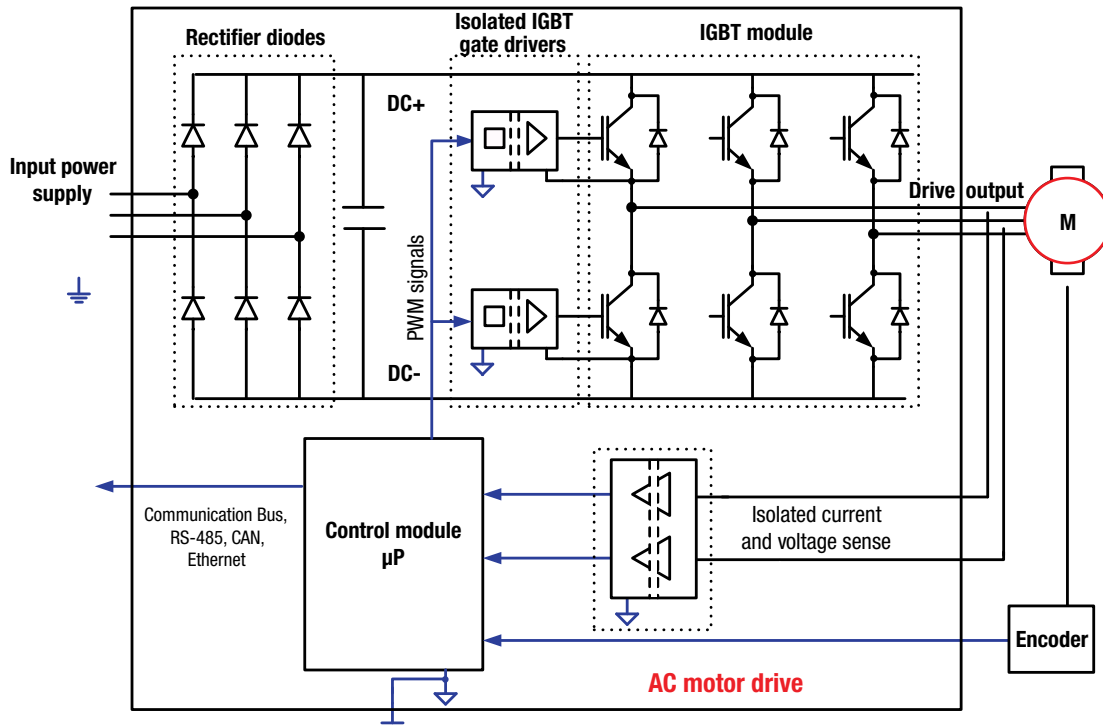

**Figure 1.** Control for a three-phase AC induction motor.

Accurate motor control also requires extremely high-speed computation in real time, which is best supplied by MCUs with digital signal processor (DSP) capabilities. DSPs are also capable of performing digital filtering and other functions to help protect systems from power transients and other signal flaws, while at the same time reducing the need for analog components that perform these functions.

While dedicated logic and general-purpose MCUs might be used for low-cost applications where basic control is sufficient, industrial motors in robots and other advanced manufacturing equipment require instantaneous response and accuracy, as well as the programming flexibility and advanced algorithms that digital signal control MCUs offer.

One of the biggest challenges of motor-control systems is in designing high-resolution current and voltage sensing feedback. Designs may measure current feedback from only one shunt, but a more thorough (if more compute-intensive) approach measures feedback from all three shunts. To avoid the possibility of analog signal loss or interference, designers increasingly digitize feedback signals as close to the sensor as possible. However, digital feedback signals can have potential problems with timing, especially as clock speeds increase and sampling rates rise, which brings narrower timing windows. Different trace lengths for clocks and data signals can intensify this problem, potentially causing data errors if the signals drift as components heat up during operation. Good design practices using advanced signal modulators can minimize these problems; algorithms that modify variables in keeping with temperature gain can compensate as well.

The more precise the application requirements, the more carefully the motor has to deal with changes in temperature, voltage input, timing and other factors. For example, a robot arm that moves an object in a straight line in three-dimensional space may change its trajectory when the system is operating at a high temperature, unless the control design compensates for these changes with temperature sensing and algorithm adjustments. These same types of

on-the-fly adjustments may be necessary to enable fine-grained robotic pick-and-place movements to consistently measure in micrometers, instead of drifting with heat into less precise movements with tolerances in millimeters. Given that manufacturing environments are often highly demanding in terms of temperature, dust, vibration and other stresses, it is even more important to carefully design motor-control electronics for precise operation that is consistent throughout a wide range of conditions.

### Enabling technologies for motor-drive control

TI offers technology to help with the design of precise motor-control and reliable driver electronics that can operate effectively in today's integrated manufacturing environments. The company's solutions include isolated and nonisolated switching gate drivers, feedback signal conversion, and high-speed processing for real-time control, as well as auxiliary functions such as programmable clock generators and DC/DC power supplies. For advanced SMPS and three-phase inverter designs, TI provides high-frequency [gallium-nitride \(GaN\) gate drivers](#) and modules that include GaN switches and gate drivers. For lower-voltage three-phase inverters, TI provides high-performance smart gate drivers, drivers with built-in FETs and drivers with integrated control, which result in simplified but accurate control and very short development times. Products include safety features, such as reinforced isolation that meets industrial specifications, and they are tested and qualified for use in harsh industrial environments.

Among the most important recent TI innovations for motor control is the [AMC1306](#) isolated delta-sigma modulator, a device that digitizes signals from current and other sensors and outputs a combined data and clock signal for maximum timing efficiency. The AMC1306 integrates TI's integrated capacitive isolation technology in series to achieve reinforced isolation in a minimal footprint. Delta-sigma analog-to-digital conversion of the change in sensor output level is followed by Manchester coding of the clock rate onto the data stream, as shown in **Figure 2** (next page).



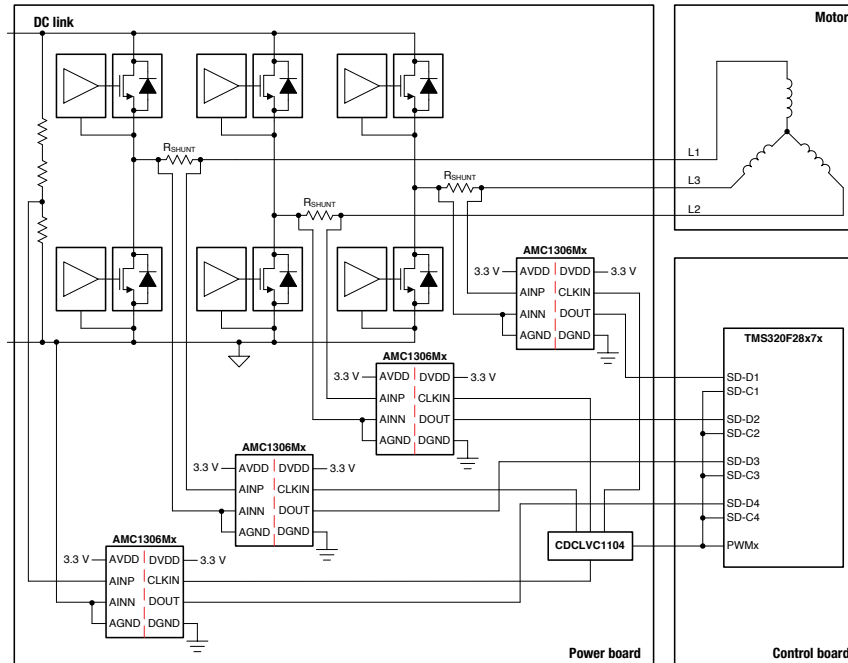

Figure 2. Reinforced isolated phase current-sense reference design with small delta-sigma modulators.

The result is a highly robust signal that significantly decreases problems with setup and hold times, which can occur with changes in operating temperature, thus simplifying the design and routing of three-phase motor-control systems.

### Manchester coding with the clock embedded in the data stream

To help implement the AMC1306 modulator, TI created the [Reinforced Isolated Phase Current Sense Reference Design with Small Delta Sigma Modulators reference design](#). Figure 2 shows the functions of the reference design, including the AMC1306 used for current-, temperature- and voltage-sensing signals. (The device is used for current sensing on all three power signals to the motor shunts, but to reduce detail, Figure 2 shows only one signal.) The dotted red line within the reference design's circuits, indicates that it is effectively isolated for safety. Breaks within the AMC1306 triangles indicate specific points of reinforced isolation, as do the dotted red lines within the UCC5320 and UCC23513 insulated gate bipolar transistor (IGBT) switch drivers, which also feature TI's integrated capacitive isolation technology.

Figure 2 shows control processing using a [TMS320F28379D](#) 32-bit floating-point MCU, part of TI's family of

C2000™ real-time MCUs designed for high-performance computation and programming ease, along with a peripheral set for use in control systems. The [C2000 Motor Control SDK](#) software platform, with support for a wide variety of motor types, helps speed algorithm development and system implementation. InstaSPIN™ motor-control solutions provide algorithms, tools and reference designs for evaluation, fast learning and quick development. TI's DSP and analog expertise combine in comprehensive solutions that save developers time when designing advanced motor drive control.

### Precise motors for integrated manufacturing

Industries are moving ahead with more precise control, greater communication among machines, a wider range of sensing inputs, and new capabilities in robotics and artificial intelligence. These advances are leading to a new level of integrated automation and data exchange known as the fourth industrial revolution, or [Industry 4.0](#).

Precisely controlled motors make an important contribution to Industry 4.0, since they drive almost every motion made by industrial machines. TI's advanced technology has played a significant role in bringing about high-resolution motor control, and it continues to help manufacturers push motor and motion control to higher levels.

### 2.2.9 Getting the most out of your power stage at the full temperature range

When designing a power stage for motor control, you can drive down the total system cost if you make special considerations regarding efficiency. This includes optimizing the field-effect transistor, switch node and control algorithms. During design, you will need to protect the system against an over-temperature condition. If the system gets to a certain temperature level, the components on the printed circuit board (PCB) are outside their specification ranges, which can damage the components and cause the drive system to malfunction.

Temperature sensors monitor and protect power-stage components to keep the drive system within the safe operating area (SOA). An SOA is a defined operating temperature range for a system at a specific apparent load or root-mean-square (RMS) current in a phase that the drive can support without extra cooling abilities. The temperature range for industrial equipment is typically an ambient temperature of -40°C to 85°C.

**Figure 1** shows an SOA curve generated with [48-V/500-W Three-Phase Inverter with Smart Gate Driver Reference Design for Servo Drives](#). The curve is defined based on results from thermal camera testing and an efficiency measurement at 10 A<sub>RMS</sub>. With an assumed zero temperature error, it is possible to use this curve as a reference against a negative temperature coefficient (NTC) thermistor and TI’s TMP235A2 sensors. The difference in the SOA is a result of the temperature error of the sensors and indicates the need for a safety margin in order to ensure operation within the SOA of the drive.

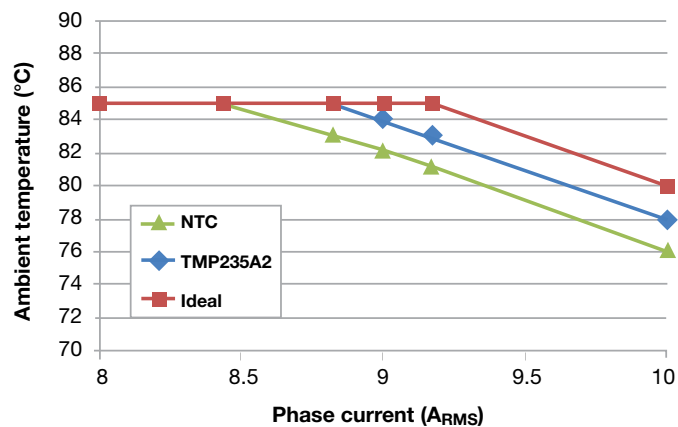
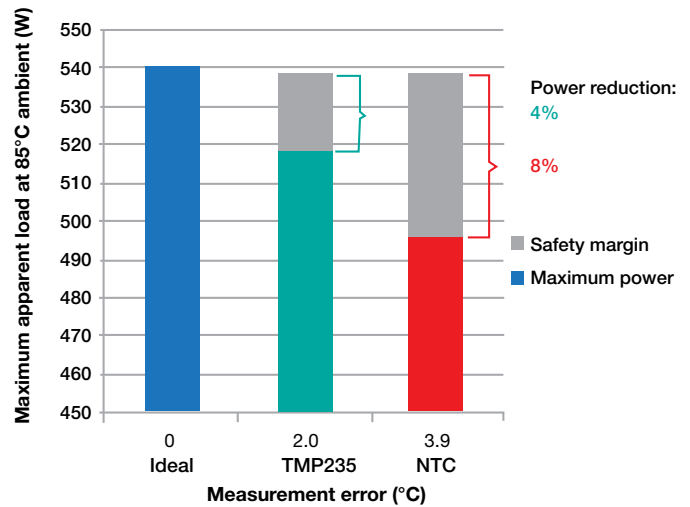

**Figure 1.** SOA differences caused by sensor temperature error compensation.

### How does the temperature error degradation of the SOA affect system performance?

Figure 1 illustrates the effect that temperature error has in regards to RMS current at ambient temperature, assuming that the NTC has an error of 3.9°C and that the TMP235A2 has an error of 2.0°C. Using the SOA curve on the maximum phase current with regards to ambient temperature, it is possible to define the maximum phase current possible before cooling is required. You can use this maximum phase current to calculate the power degradation of the power stage given a specific temperature sensor error.

**Figure 2** is based on calculations found in the three-phase inverter reference design.



**Figure 2.** The usable apparent load at 85°C using different temperature sensors.

You can see that the power stage can support 539 W – if it was possible to measure the temperature without error. Now, because of the temperature error of the sensor, you’ll need to add a safety margin. This safety margin means that the power stage needs to be degraded by 4% or 8% of the potential power usage of a servo drive power-stage module system. If the power stage needs to support 500 W (which is clearly possible, as shown in Figure 1) but you choose to use an NTC, you would need to add additional cooling to the system to support the system’s full temperature range, or redesign the system for higher efficiency.

To ensure that the power stage is only used under recommended temperatures, a temperature sensor monitors the temperature and shuts down the power stage in the event of an over-temperature condition. The accuracy of the temperature sensor affects the power stage's maximum temperature limit due to the temperature safety margin. Below we discuss how to generate the right configurations to get the most out of your power stage, and some of the considerations you should keep in mind for your design.

Above, we identified that temperature sensor error introduces a safety margin that affects the safe operating area of the power stage. Aside from sensor error, another error not accounted for in the comparison shown in Figure 1 is the analog-to-digital converter (ADC) error, since both the TMP235A2 and negative temperature coefficient thermistor (NTC) are delivering an analog signal. The ADC error will affect both signals equally, however at hotter temperatures NTCs become very nonlinear which adds to the challenge of obtaining an accurate measurement. A silicon temperature sensor like the TMP235 maintains its linearity across temperature, making it easier to compensate the error.

A digital temperature sensor like the TMP117 can eliminate the ADC error and achieve an apparent load that's much closer to the "ideal" curve achieved using a thermal camera.

When your system is operating at an ambient temperature of 85°C, the PCB and ICs are in fact working at a higher temperature due to the self-heating of the ICs. A typical industrial-grade IC has an operating temperature of 125°C or higher.

When the ambient temperature is 85°C, the self-heating of the ICs can only raise the IC up to 40°C. If the IC gets to a higher temperature the IC is working outside of temperature range. For more details about self-heating, see the 48-V, 500-W Three-Phase Inverter with [Smart Gate Driver Reference Design for Servo Drives design guide](#).

To avoid working outside the recommended temperature range, you need to ensure that your system does not exceed temperatures higher than 125°C. In the smart gate driver reference design, a thermal camera measures the temperature. In a real system, either a thermistor or IC sensor would measure this temperature. In the comparison shown in Figure 1, a small error is introduced into the calculations by incorrectly assuming that the thermal camera has no error and is ideal. A resistance temperature detector probe would offer a more accurate baseline method of sensing.

The various methods of the various sensor types add a measurement error, which needs to be compensated from the ideal measurement. The smaller the error, the more power the three-phase inverter can supply before the system must turn off due to an over-temperature error. In other words, the temperature sensor will limit your overall system's apparent load capabilities without even looking at the gate driver, FETs or any of the other factors affecting power-stage efficiency. This is why temperature sensor accuracy is so important.

What does this mean for your design? Let's use the smart gate driver reference design as an example and compare the temperature error of an NTC thermistor with the TMP235A2 IC temperature sensor. First, how do you quantify the temperature error?

Looking at the TMP235A2's data sheet, it has a temperature error of  $\pm 2^\circ\text{C}$  for the full temperature range. There is a small footnote in the data sheet that refers to the lookup table used to correct the device for temperature drift.

For the NTC, it takes a little more time to calculate the error. Mathematical equations can generate a model that you can use to calculate the error in Celsius degrees. The equations can typically be found on the NTC data sheet or NTC application notes. With these equations, you can generate the curves representing the NTC model, as seen in the TMP6131 parameter simulator.

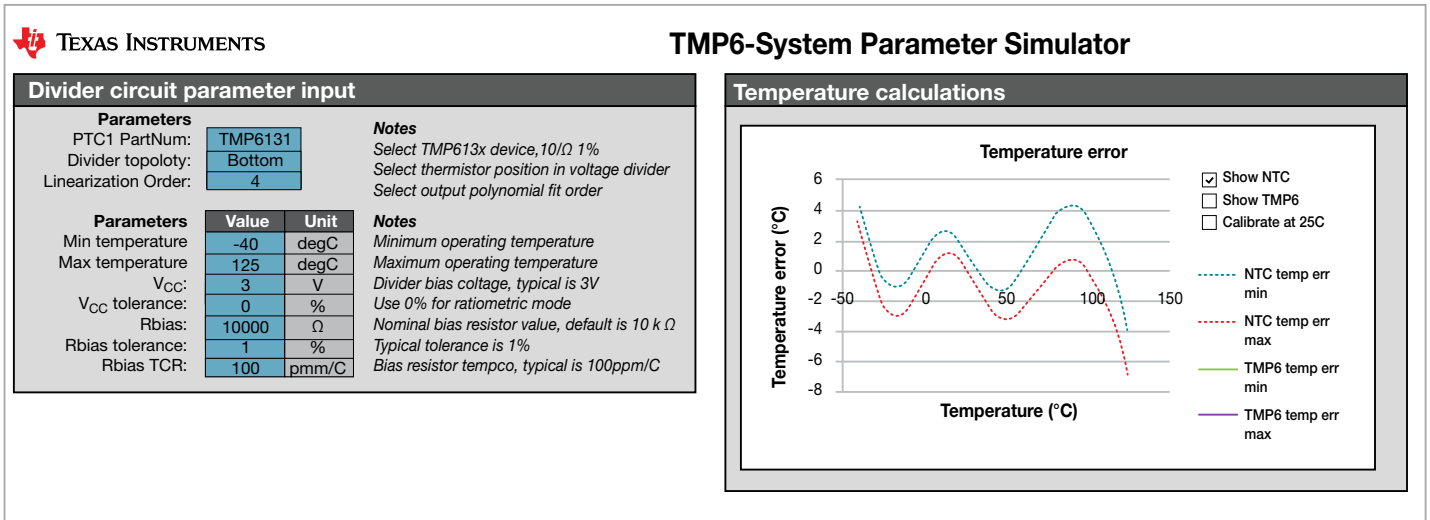

Figure 3. Temperature error calculation of an NTC using the TMP6131 system parameter simulator.

The TMP6131 system parameter simulator can simulate the NTC model and estimate the accuracy when applying polynomial fitting, as opposed to a lookup table. **Figure 3** shows the setting used for the simulation and the result.

The blue curve in Figure 2 defines the temperature error. The area used is from -40°C to +125°C. You can see that the maximum negative and positive error is -3.6°C and +4.3°C, respectively. For ease of calculation let's normalize this temperature error range to ±3.9°C of the NTC. Due to the NTC's nonlinearity over temperature, the compensation should occur in the temperature range specified for the system.

There are two basic ways to linearize thermistors in software: polynomial fitting and a lookup table. These methods will get the NTC, PTC and or TMP235A2 measurements closer to the ideal measurement and actual temperature. In the simulation tool, polynomial fitting will reduce the linearization error. Using a higher polynomial fitting order increases the NTC's accuracy, but also increases the time it takes for the processor to calculate the temperature. This extra calculation time results in additional power consumption, which also affects system efficiency. The lookup tables require processor memory.

Calibration errors are not considered in the simulation, but will affect both the sensors similarly.

This chapter section defined the NTC accuracy error as ±3.9°C and the TMP235A2 error as ±2°C, and discussed how these errors translate into a derating of

the total apparent power of the power stage and provided understanding on the effect the temperature sensor error has on the power stage system performance.

### 2.2.10 Anything but discrete: how to simplify a 48-V to 60-V<sub>DC</sub>-fed three-phase inverter design

Imagine that you're designing the next power stage of a servo, computer numerical control (CNC) or robotics application. In this instance, the power stage is a low-voltage DC-fed three-phase inverter for voltages ranging from 12 V<sub>DC</sub> to 60 V<sub>DC</sub>, with power ratings less than 1 kW. This voltage rating covers the range typically used for battery voltages in battery-operated motor systems or low-voltage DC-fed motor systems. On top of this, your boss says, "By the way, you need to design this to work without extra cooling of the power stage. It has to be as small as possible to fit the target application needs and of course it needs to be low cost."

#### No problem, right?

Well, in this case, there is a approachable solution for designing an inverter that meets the demands of this hypothetical – albeit demanding – boss.

But before you start defining the specified power stage, current sensing and protection circuit, it is important to consider a very real and accessible reference design for a 48-V/500-W three-phase inverter with smart gate driver servo drives.

The [48V/500W Three-Phase Inverter with Smart Gate Driver Reference Design for Servo Drives](#) achieves a small form factor using highly integrated circuits that include three half-bridge gate drivers with 100% duty-cycle operation and selectable source/sink currents from 50 mA to 2 A.  $V_{DS}$  sensing enables overcurrent protection, which prevents damage to the power stage and motor. The  $V_{GS}$  handshake feature protects the power stage against shoot-through caused by erroneous pulse-width modulation configurations. A typical low-voltage DC-fed servo drive power stage can be partitioned like **Figure 1**, which is based on the DC-fed servo drive power-stage module. The boxes outlined in red are the modules.

The covered modules of the low-voltage DC-fed servo drive in Figure 1 have a huge impact on system performance and affect the design considerations.

It is possible to build a robust system by adding fault detection to the half-bridge gate drivers for  $V_{DS}$  sensing and soft shutdown. These integrated features enable the gate-driver system to detect typical overcurrent or when short-circuit events take place, without adding extra current sensing or hardware circuits to enable dead-time insertion. Thus, the MCU can't provide a wrong drive signal and damage either the power stage or the motor with a shoot-through short circuit.

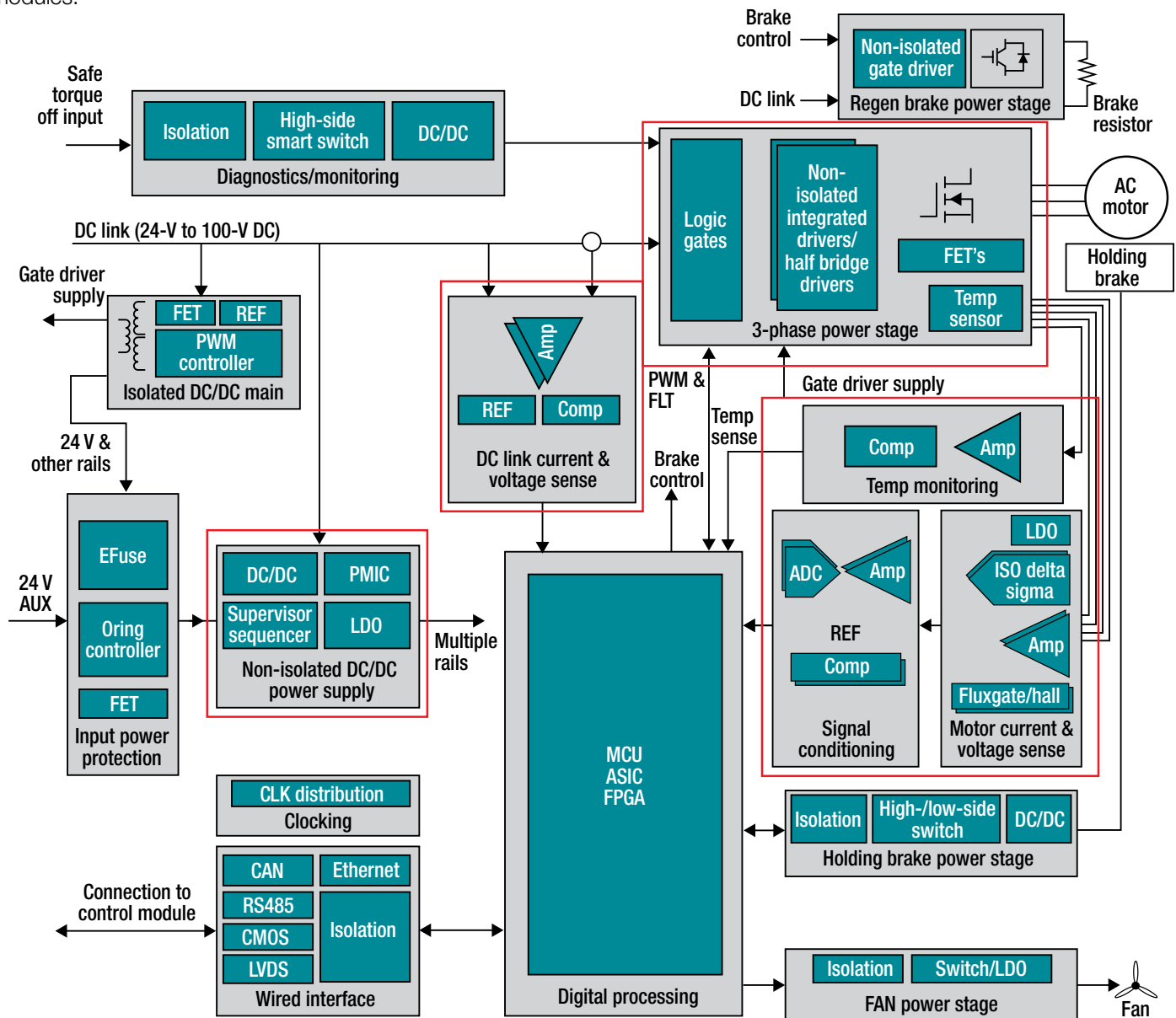

Figure 1. DC-fed servo power stage.



One consideration in building a robust system is optimizing efficiency to reduce cost for the heat sink and radiated emissions (electromagnetic interference) versus the switching speed. Implementing these features with 100-V single- or half-bridge FET gate drivers requires additional active and passive components, which increases bill-of-materials (BOM) cost and PCB size, while reducing the flexibility to modify parameters like the strength of the gate drive. When analyzing the system efficiency the current sensing circuit, FETs with low  $R_{DS(on)}$  and a low gate charge to enable fast switching affect the system efficiency performance. System designers typically want to achieve 99% efficiency of the power stage.

To enable continuous phase-current sensing with minimum losses, the reference design uses 1-m $\Omega$  in-line shunts. The resistor value is a compromise between accuracy and efficiency.

A major challenge for nonisolated in-line amplifiers is the wide common-mode voltage (0 V to 80 V) used for the system, considering that the shunt full-scale voltage is  $\pm 30$  mV in this reference design (designed for  $\pm 30$  A<sub>RMS</sub>). This is a small signal compared to the common-mode voltage of 48 V. Therefore, you will need a current-sense amplifier with a large common-mode voltage range and very high DC and AC common-mode rejection. Because of the low shunt

impedance, an amplifier with an additional integrated fixed gain and zero offset further helps reduce system cost while ensuring highly accurate current measurements.

An 100-V<sub>DC</sub> buck regulator creates an intermediate rail from the DC input to supply the gate driver and point of load. The power stage needs to work at a high efficiency to reduce self-heating in order to meet the industry's ambient temperature of operation, which is typically 85°C. Given this requirement the ICs used in the system need to support even higher temperatures, as the electronics will always have some temperature increase (self-heating).

The reference design for servo drives was tested from 0 W to 500 W of output power with a permanent magnet synchronous motor. **Figure 2** shows that the motor load was controlled with a dynamometer.

### Conclusion

The three-phase inverter reference design shows how to design a compact hardware-protected power stage with low BOM count, in-phase current sensing, fault diagnostic capabilities and high efficiency. The reference design uses the TI's DRV8530 100-V three-phase smart gate driver with buck regulator and the INA240 80-V, low-/high-side, bidirectional zero-drift current-sense amplifier with enhanced pulse-width modulation rejection, which enables optimization of a low-voltage DC-fed power stage.

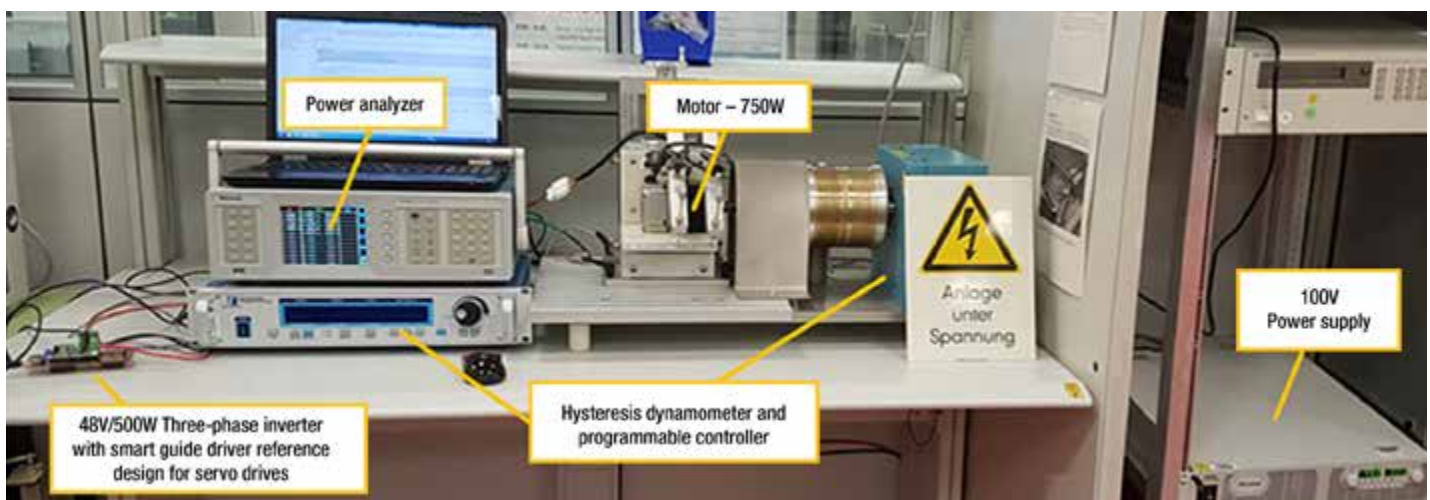

**Figure 2.** Test setup of the motor drive power stage.

### 2.2.11 Selecting amplifiers for shunt-based current sensing in three-phase motor drives

Accurate phase-current sensing has a significant impact on the performance of vector-controlled three-phase inverters for industrial motor drives. The motor phase currents can be measured through Hall-effect, fluxgate or transformer-based magnetic sensors, or through shunt resistors. Magnetic sensors offer inherent isolation and a wide current range, while shunt solutions offer cost-effective, highly linear and high-bandwidth sensing options. Phase currents can be as high as 100 A with three-phase inverters operating from

110 to 690 VAC or from 12 to 60 VDC. To get the motor phase currents, shunts are typically placed either at the DC-link return to ground, between the bottom switch and ground, or in-line with the three-phase power to the motor (see **Figure 1**).

Each shunt placement has advantages and challenges, and specific requirements so that the amplifier can convert the small shunt voltage into an analog or digital signal for processing by a microcontroller (MCU). **Figure 2** shows the ideal shunt current versus the phase current over one pulse-width modulation (PWM) cycle for each shunt placement.

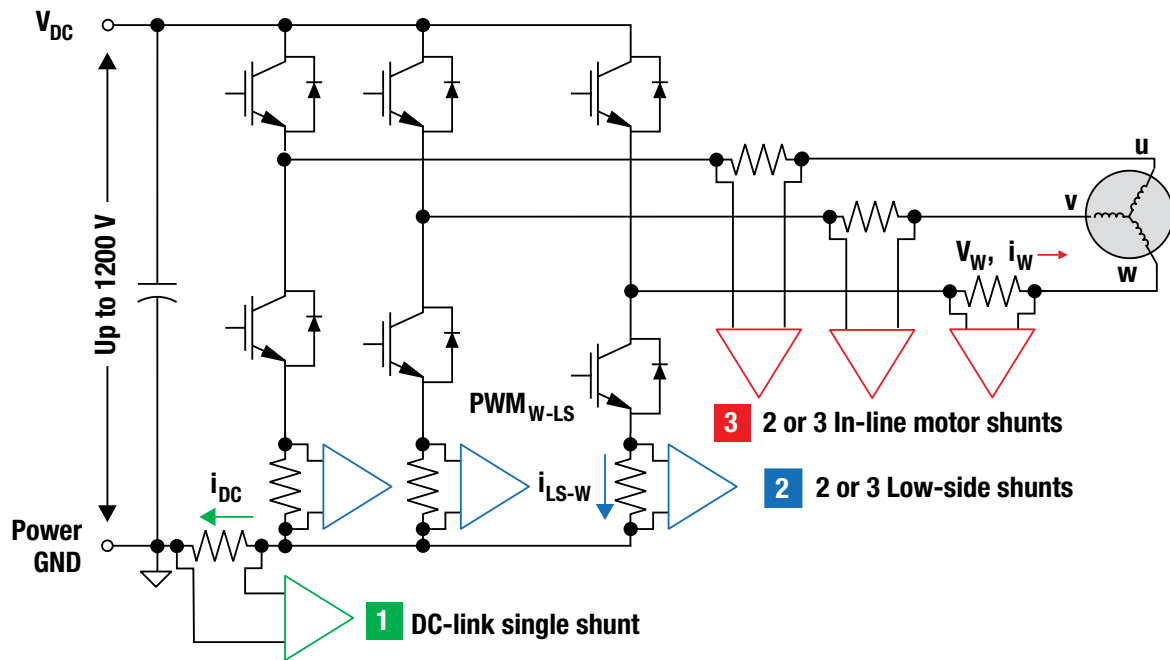

Figure 1. Current-shunt options in three-phase inverters.

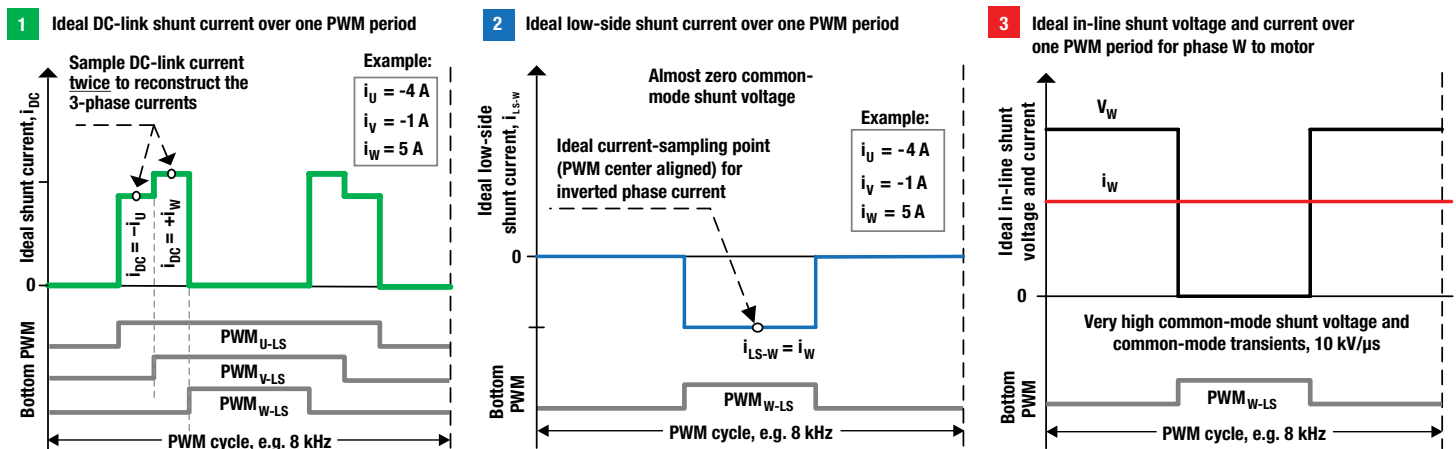

Figure 2. Shunt current vs. phase current and common mode depending on shunt placement.

From a system view, the motor in-line shunts offer major performance advantages, while from an amplifier view, the low-side shunts enable lower-cost solutions, as shown in

**Table 1.**

In shunt-based systems, the shunt resistance and package are a compromise between accuracy, thermal performance, PCB size and cost. In motor drives, the shunt resistance is such that the voltage drop at the maximum phase current is typically from  $\pm 25$  mV to  $\pm 250$  mV. The subsequent amplifier converts the small bipolar shunt voltage into a typically unipolar output voltage, with bias offset matched to the ADC's 3-V to 5-V input range. Gain settings are typically from 10 to 100 V.

For each of the three shunt placements, the shunt resistance tolerance and drift, as well as the amplifier's gain, input offset and related drift over temperature, have similar impacts on accuracy.

Consider a shunt with a  $\pm 50$ -mV maximum voltage (100-mV full-scale input range), and assume that each parameter will not contribute more than  $\pm 0.1\%$  to the absolute error over the industrial temperature range. The amplifier input-offset voltage cannot be  $\leq 100$   $\mu$ V and the offset drift must be  $\leq 1$   $\mu$ V/ $^{\circ}$ C. The amplifier's gain-set resistors, as well as the shunt, are required to have 0.1% tolerance with a drift of  $\leq 10$  ppm/ $^{\circ}$ C. Of course, not all drives require this accuracy and parameter scale. Unlike the gain error, the offset error is often more critical, as it contributes to an absolute error that is independent of the current magnitude, and thus especially impacts inverter performance at lower currents.

**Placement No. 1: a single DC-link to ground shunt**

A single DC-link shunt is more common in low-cost, low-power, vector-controlled fans and pumps than in industrial AC and servo drives. The DC-link current must be measured twice per PWM cycle at two different PWM switching states to reconstruct the three-phase currents. The short measurement cycle at small voltages requires amplifiers like the OPA835 from TI. This amplifier offers a high large-signal unity-gain bandwidth of at least 20 MHz and high slew rates ( $>10$  V/ $\mu$ s) to settle in  $<1$   $\mu$ s. The method won't work for zero phase voltage since all three PWM duty cycles are 50%, unless extended with sophisticated PWM compensation algorithms.

**Placement No. 2: low-side current shunts**

Using low-side current shunts are attractive for compact AC-line-fed inverters up to approximately 5 kW and for 12- to 60- $V_{DC}$ -fed motor drives, where the control MCU is nonisolated and connected to power ground. The shunts might be placed in two or three legs of the three-phase inverter.

The amplifier should operate from a single supply, as should the subsequent ADC. Since the shunt voltage drop is referenced to ground, an input common-mode voltage near the ground negative rail is crucial. To decouple from ground bounces during switching, an amplifier in a differential to single-ended configuration will convert the small bipolar shunt voltage into a unipolar voltage, typically 0 V to 3.3 V

	Advantages	Challenges	Accuracy
In-line motor shunts	<ul style="list-style-type: none"> <li>• Direct, continuous phase current sense.</li> <li>• Allows averaging phase current over on PWM cycle for higher accuracy and/or a current controller can run twice per PWM.</li> <li>• Detection of phase-to-phase and phase-to-GND shorts.</li> </ul>	<ul style="list-style-type: none"> <li>• Amplifier requires high common-mode input voltage with a high common-mode rejection ratio (CMRR).</li> <li>• AC line-fed inverters typically use an isolated approach.</li> </ul>	High
Low-side shunts	<ul style="list-style-type: none"> <li>• Can detect shoot-through.</li> <li>• Lower system cost: due to near zero common mode input voltage a non-isolated current sense amplifier/op amp can be used.</li> </ul>	<ul style="list-style-type: none"> <li>• Indirect, discontinuous inverted phase-current sense. Can be measured only when low-side switch is on.</li> <li>• Cannot average over one PWM period and run the current controller twice per PWM</li> <li>• Cannot detect phase-to-GND shorts.</li> </ul>	Medium
DC-link single shunt	<ul style="list-style-type: none"> <li>• Works with both vector control and trapezoidal control.</li> <li>• Lower system cost: due to near zero common mode input voltage a non-isolated current sense amplifier/op amp can be used.</li> </ul>	<ul style="list-style-type: none"> <li>• Requires two measurements synchronized to the PWM pattern in each PWM cycle.</li> <li>• Requires a minimum duration of each active PWM pattern and PWM compensation algorithms to ensure a minimum duration.</li> <li>• Requires an amplifier with a high bandwidth and slew rate.</li> </ul>	Low

**Table 1.** Comparison of shunt placement for motor phase-current measurement.

with 1.65 V mid-bias, to drive the ADC. Key parameters for the amplifier are:

- A rail-to-rail input with a near-zero input common-mode voltage.
- A rail-to-rail output.
- A single supply voltage.
- Offset and offset drift, which might not be critical because it is possible to measure offset at each PWM cycle when the low-side switch is off.
- Bandwidth and slew rate, which impact the minimum settling time, and which should be smaller than the specific minimum on-time for the low-side switch.

When using three shunts, a workaround for a low-side on-time that is too small is to only consider the two phases with the highest on-time and calculate the third phase. This approach won't work for the two-shunt solution, however; the amplifier has to settle at least within the minimum on-time specified, typically even at half the minimum on-time since the current is often sampled symmetrically to the PWM.

**Table 2** provides example settling times for an amplifier with a unity gain bandwidth of 10 MHz, like the TLV9062. The TLV9062 meets these specifications and offers dual amplifiers in a single 8-pin package hence minimizing the BOM for systems that use the two low-side leg shunt approach.

To further reduce the BOM, designers can eliminate the need for external gain setting resistors and amplifiers with internal

fixed gain settings like the INA181, INA2181 (dual channel), and INA4181 (quad channel) current sense amplifiers.

### Placement No. 3: in-line motor shunts

For 12-V to 60-V<sub>DC</sub>-fed inverters, non-isolated current-sense amplifiers referenced to GND of DC- are attractive due to their system cost. The major challenge is the huge common-mode voltage, which is 100 to 1,000 times higher than even the full-scale shunt voltage. This requires amplifiers with:

- A very high DC and AC common-mode rejection ratio (CMRR) for accurate current measurements without long recovery ripple after transients. The DC CMRR should be at least -100 dB and the output should settle within a few microseconds. **Table 3** outlines the impact of CMRR.
- A wide common-mode voltage range from at least -1 V to 70 V for margin during switching and DC-link voltage increase during motor braking.

The amplifier should operate from a single 3.3-V supply, as should the subsequent ADC or MCU-embedded ADC. This eliminates the need for clamping diodes to protect the ADC input. An amplifier bandwidth at a configured gain of 400 kHz allows overcurrent detection as fast as  $\leq 1 \mu\text{s}$  (10% to 90%). It's not possible to compensate for offset and gain error easily in this configuration, especially over the operating temperature range. As outlined before, the offset and offset drift are critical for the inverter's low-current performance and the acceptable offset error depends on the desired current-measurement accuracy.

Operational amplifier	Gain	Bandwidth	Minimum slew rate at 3.3 V	Settling time to 1%	Settling time to 3%
10 MHz	20	500 kHz	$\geq 3 \text{ V}/\mu\text{s}$	1.5 $\mu\text{s}$	1.1 $\mu\text{s}$
10 MHz	50	200 kHz	$\geq 1.2 \text{ V}/\mu\text{s}$	3.7 $\mu\text{s}$	2.7 $\mu\text{s}$

**Table 2.** Settling time versus amplifier gain bandwidth.

Parameter	Value	Accuracy versus $\pm 50 \text{ mW}$	Comment
CMRR (DC)	-120 dB	0.1%	At 48-V common mode
CMRR (AC)	-90 dB	3.3%	At 0-V to 48-V common-mode transient, fast settling required "PWM rejection"

**Table 3.** Impact of CMRR on accuracy.

**Figure 3** shows a transient response of a current-sense amplifier with enhanced PWM rejection (the INA240) with a 48-V three-phase GaN inverter. Thanks to high DC and AC common-mode rejection, the phase current settles within around 2.5  $\mu\text{s}$ . Assuming a center-aligned sampling, the minimum PWM on or off time required to accurately measure the corresponding phase current is 5  $\mu\text{s}$ . For lower on/off times, the three-shunt approach enables the calculation of the third-phase current from the other two phases with higher on/off times.

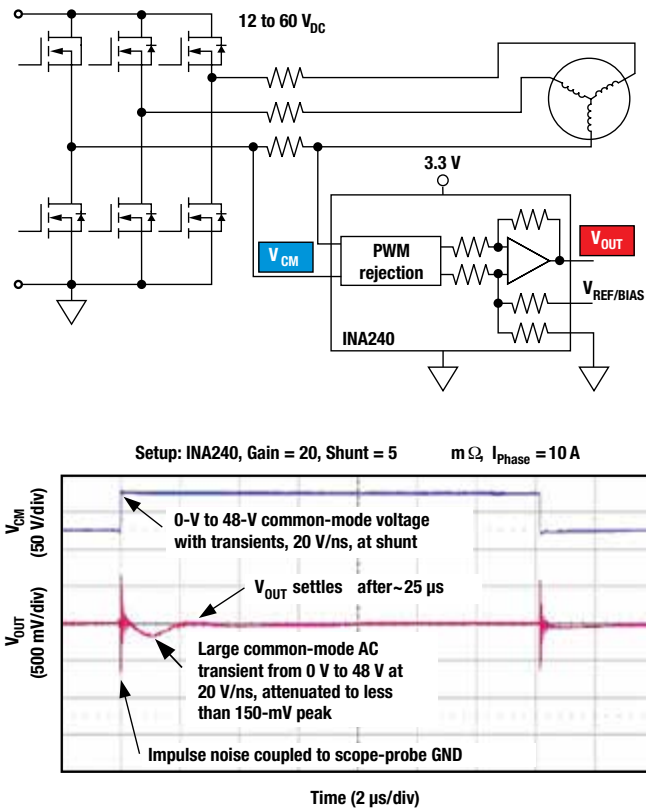

**Figure 3.** In-line current-sense amplifier and transient response over one PWM cycle at 48 V.

### Isolated in-line phase-current sensing

For AC line-fed inverters with DC-link voltages from 300 to 1,200 VDC, an isolated amplifier or delta-sigma modulator provides accurate phase-current sensing with in-line shunts. The isolation function enables rejection of the large common-mode voltage and transients shown in Table 1. Since industrial motor drives are required to meet International

Electrotechnical Commission (IEC) 61800-5-1 electrical-safety requirements, basic or reinforced insulation is required. Basic or reinforced isolated amplifiers and delta-sigma modulators serve this purpose.

### Isolated delta-sigma modulators

**Figure 4 (next page)** shows the isolated phase-current measurement with an in-line shunt and isolated delta-sigma modulator. The measurement can be applied to three phases or two phases, with the third phase current calculated accordingly. The floating shunt voltage is low-pass filtered, amplified and fed into a second-order delta-sigma modulator, which is isolated from the output. The isolated output is a bitstream of ones and zeros at the modulator clock frequency, typically from 5 MHz to 20 MHz. A decimation filter in the MCU must process the bitstream to get an accurate high-resolution result.

From a system perspective, isolated delta-sigma modulators should offer:

- A gain amplifier with an anti-aliasing filter.
  - A  $\pm 50\text{-mV}$  input range reduces shunt losses by 80% compared to the traditional  $\pm 250\text{-mV}$  range.
  - Very low gain, offset and related drift are crucial for accuracy, since it is difficult to compensate for them. A very low  $50\text{-}\mu\text{V}$  offset with  $1\text{-}\mu\text{V}/^\circ\text{C}$  drift contributes to less than 0.11% error over a temperature range from  $25^\circ\text{C}$  to  $85^\circ\text{C}$ .
  - An integrated anti-aliasing filter attenuates noise above half the modulator clock frequency to avoid it folding back and impacting accuracy in the band of interest.
  - The common-mode input voltage should be at least half the negative full-scale input range.
- A delta-sigma modulator running a 20-MHz clock to enable highly accurate, highly linear current sensing at low latency. Modulators with the Manchester-coded bitstream option enable easier clock routing from the processor to each of the three modulators.
- A wide-range high-side supply voltage and low current consumption, preferably with an integrated low-dropout regulator such as the AMC1304, to enable use of the floating-gate drive supply.



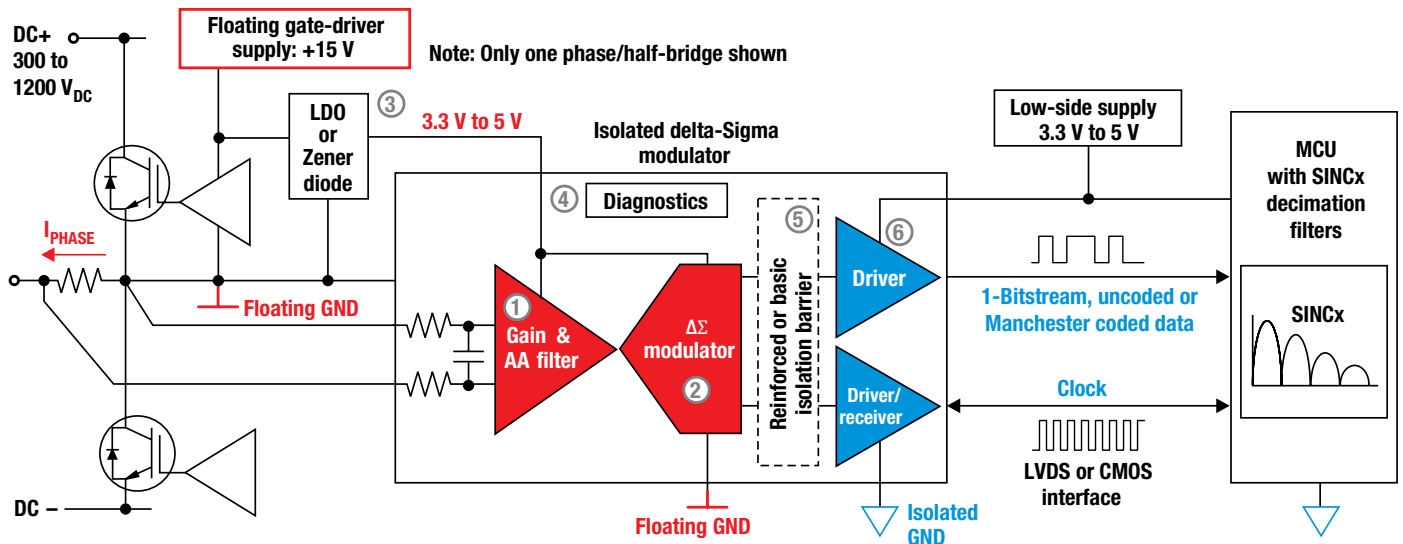

Figure 4. In-line shunt-based phase-current sensing with an isolated delta-sigma modulator.

- A diagnostic function that detects a loss of high-side power to avoid unpredictable measurements.
- Basic or reinforced isolation, with high immunity against electromagnetic fields and high common-mode transient immunity (CMTI) of at least 10 kV/μs to reject switch-node transients.
- A complementary metal-oxide semiconductor or low-voltage differential signaling (LVDS) digital interface option. In noisy environments or for longer traces, LVDS offers higher common-mode noise immunity.

The processor’s decimation low-pass filter, such as a sinc filter, sets the bandwidth and resolution of the output signal by cutting off high-frequency noise. The effective number of bits (ENOB) and settling time increase with the sinc filter order and oversampling ratio; see Figure 5. The advantage of digital filters is that resolution versus bandwidth and settling time can be configured in software, and it is possible to apply two or more filters to the same bitstream. This advantage enables a high-resolution phase current for accurate control (for example, 12 ENOB with a sinc<sup>3</sup> filter and 64 times oversampling) and very-fast overcurrent detection (for example, 1.2 μs with a sinc<sup>3</sup> filter and 8 times oversampling).

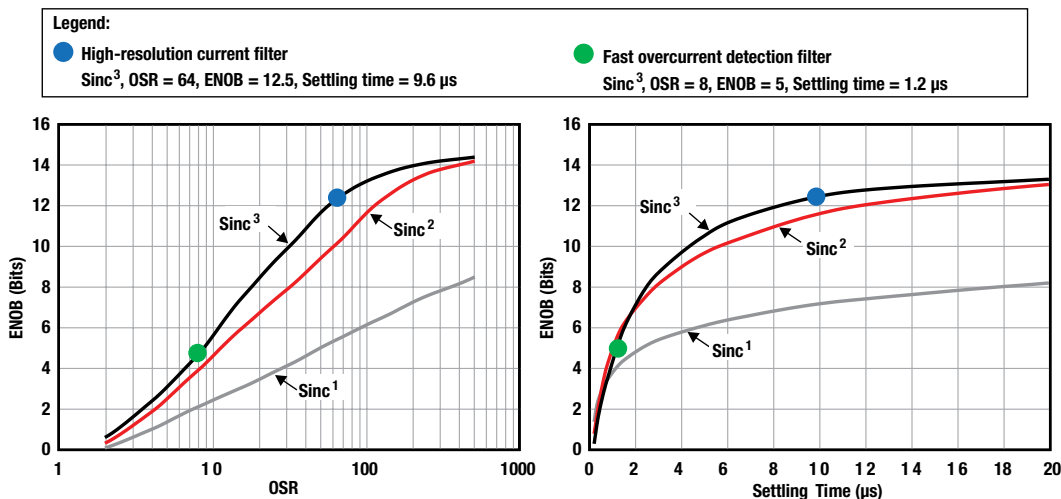

Figure 5. ENOB vs. oversampling ratio and settling time for a 20-MHz modulator clock (AMC1306).

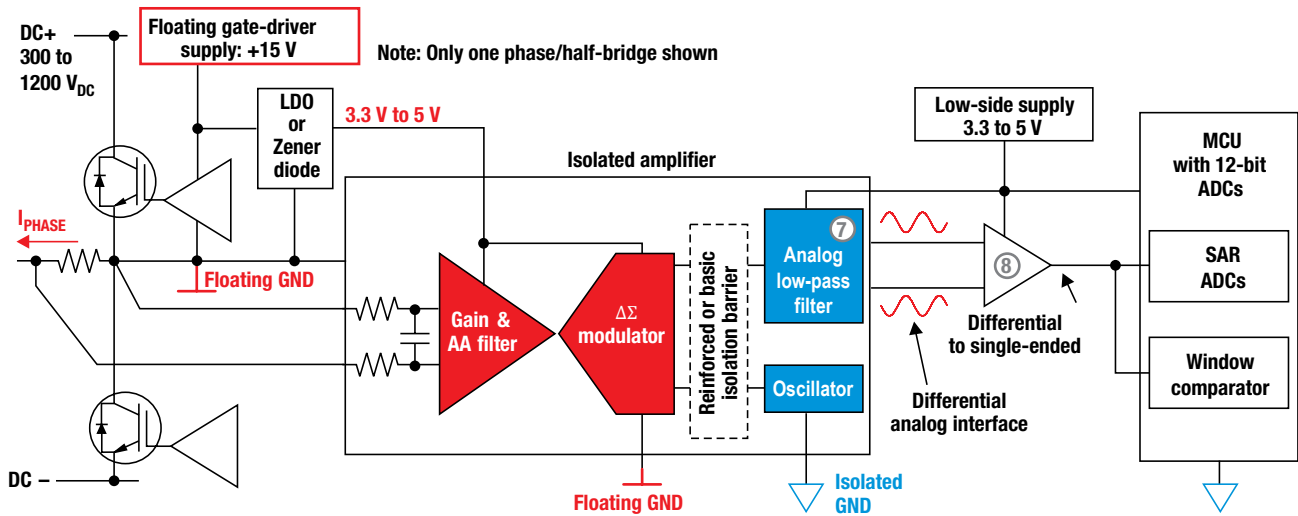

Figure 6. In-line shunt-based phase-current sensing with an isolated amplifier.

### Isolated amplifier

Figure 6 shows the phase-current sensing with an isolated amplifier. The nonisolated subsystem of the isolated amplifier (in red) is the same as the isolated delta-sigma modulator in Figure 4. The main difference is the inclusion of an output filter (the subsystem in blue). An active low-pass filter with a fixed cut-off frequency removes the high-frequency quantization noise in the bitstream and provides a high linear differential analog output. The features that a delta-sigma modulator should have listed earlier also apply to isolated amplifiers. However, the analog bandwidth and settling time are hardware-fixed and depend on the device-specific oscillator clock and low-pass filter of the isolated amplifier.

The isolated amplifier-based phase-current sensing system has three conversion stages: the isolated amplifier, an additional differential-to-single-ended amplifier and (typically)

a single-ended 12-bit successive approximation register ADC. Short-circuit detection requires an additional window comparator per phase.

A major system advantage is the simple analog interface to a wide range of MCUs with an embedded ADC. For single-ended ADCs, you will have an additional operation amplifier (op amp) that will not degrade performance. For better noise immunity, place the op amp close to the MCU to keep the analog traces differential as long as possible. From a system performance perspective, the isolated delta-sigma modulator system is superior. Table 4 provides a comparison.

### Conclusion

A TI reference design is available for each system configuration described in this article, with detailed hardware design guidelines and system test results.

Parameter	Isolated amplifier	Isolated delta-sigma modulator
Resolution/accuracy	Three conversion stages: system resolution also impacted by external ADC, typically $\leq 12$ bit.	Single analog-to-digital conversion: 16-bit resolution with 14-bit accuracy (ENOB) possible, pending digital filter configuration. See Figure 5.
Bandwidth/settling time	Fixed. High-performance amplifiers offer 300-kHz bandwidth and less than 3- $\mu$ s settling time.	Flexible. Pending digital filter on processor. See Figure 5.
Short-circuit detect	Requires additional analog hardware (window comparator).	No additional hardware required; calculated on the processor.
Interface to processor	Analog differential interface: easy to interface to any MCU with an embedded SAR ADC, but requires an additional amplifier.	CMOS or LVDS interface. Requires a higher-performance MCU/microprocessor unit (MPU) with an integrated delta-sigma interface or field-programmable gate array (FPGA).
EMC immunity	Medium, due to analog differential output signals.	High to very high, due to digital signals and LVDS interface option.

Table 4. Comparing an isolated amplifier and an isolated delta-sigma modulator.

### 2.3.1 Servo drive-related reference designs for robotic systems

<a href="#">48V/500W Three-Phase Inverter with Smart Gate Driver Reference Design for Servo Drives</a>	<p>Efficiency, protection and integration are important design factors for compact DC-fed drives up to 60 V<sub>DC</sub>. This reference design shows a three-phase inverter with a nominal 48-V<sub>DC</sub> input and 10-A<sub>RMS</sub> output current.</p>
<a href="#">Basic Isolated Three-Phase Compact Power Stage Reference Design for Industrial Drives</a>	<p>This three-phase, compact power stage reference design for industrial drives, which uses a UCC5350 gate driver to support basic capacitive isolation requirements, provides an increased lifespan and better propagation delay match over optocouplers to minimize inverter deadband distortions and losses.</p>
<a href="#">Reinforced Isolated Phase Current Sense Reference Design with Small Delta Sigma Modulators</a>	<p>This reference design realizes a reinforced isolated three-phase inverter subsystem using isolated gate bipolar transistor (IGBT) gate drivers and isolated current/voltage sensors. AMC1306E25 delta-sigma modulators perform precise in-line shunt-based motor phase current sensing.</p>
<a href="#">Three-Phase Inverter Reference Design for 200-480 VAC Drives with Opto-Emulated Input Gate Drivers</a>	<p>This reference design realizes a reinforced isolated three-phase inverter subsystem using isolated IGBT gate drivers and isolated current/voltage sensors.</p>

[Find more reference designs for your robot system controller.](#)

Contributing authors: Eddie Esparza, Jason Reeder, Martin Staebler, Nagarajan Sridhar, Mateo Begue, Mamadou Diallo, Scott Hill, Manny Soltero, Harald Parzuber, Kristen Mogensen and Martin Staebler.

## 3.1.1 How to protect battery power management systems from thermal damage

Nowadays, consumers expect their personal electronics to have a longer battery life, a shorter charge time and a smaller form factor. The increased charge and discharge currents, as well as the smaller form factor, make battery packs vulnerable to thermal damage. In addition, different battery technologies have different charging and discharging requirements that are sensitive to temperature, as shown in

**Table 1.**

Battery type	Charge temperature	Discharge temperature
Lead acid	-20°C to 50°C	-20°C to 50°C
NiCd, NiMH	0°C to 45°C	-20°C to 65°C
Li-ion	0°C to 45°C	-20°C to 60°C

**Table 1.** Common charge and discharge temperature limits for various batteries.

Batteries are typically discharged over a wider temperature range, but the charge temperature is limited. It is possible to perform fast charging safely if the cell temperature is between 10°C and 40°C. These temperature limits are tied to battery-cell chemistries and temperature-dependent chemical reactions. If charged too quickly, the cell pressure can build up and lead to venting and reduced battery life.

If the operating temperature is too high, cell degradation can occur and result in thermal runaway and explosion. If the operating temperature is too low, irreversible cell chemical reactions can occur and shorten battery life. Thus, battery temperature monitoring is critical for battery management systems.

### Thermal protection solutions

Both discrete or integrated temperature-sensing solutions can protect battery management systems from thermal damage. A discrete solution comprises a thermistor, comparator and voltage reference, as shown in **Figure 1**. This approach provides real-time thermal protection without interrupting the control processing system.

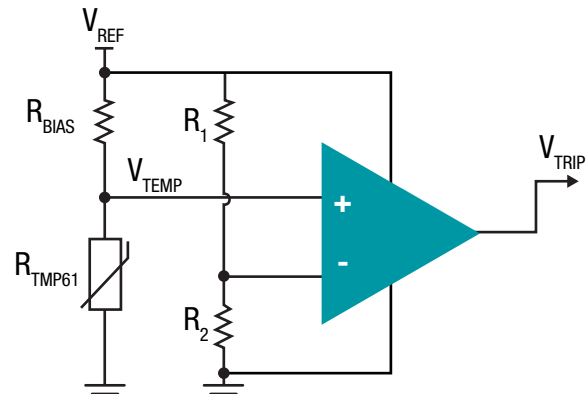

**Figure 1.** Thermistor + comparator for threshold detection.

Since battery applications require protection at both hot and cold temperatures, a temperature window comparator is a better solution. **Figure 2** illustrates an example of this output. In this example, the trip points are set to 60°C and 0°C with a 10°C hysteresis.

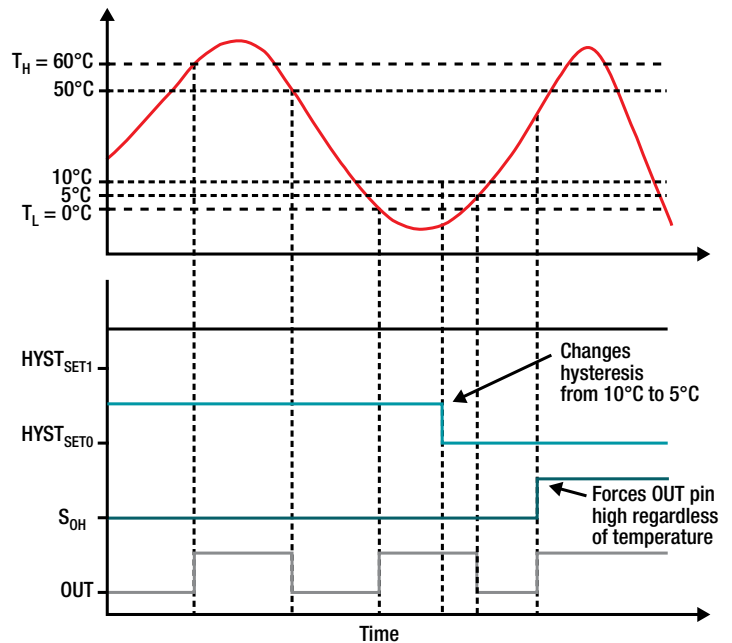
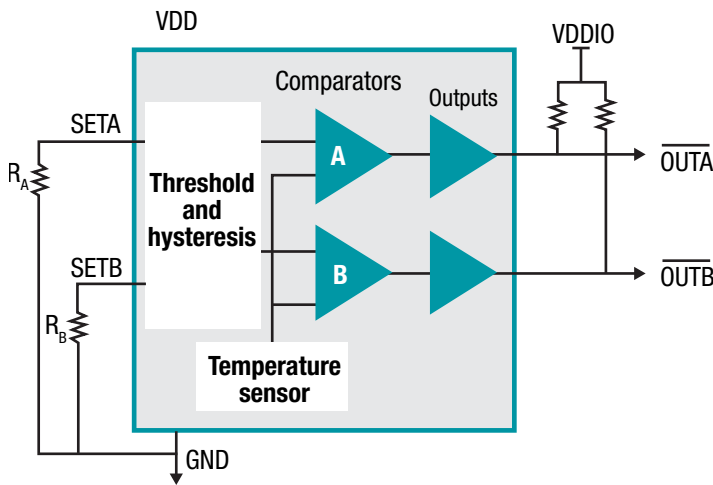

**Figure 2.** Example temperature window comparator output behavior.

Note that the set output high (SOH) in Figure 2 is a system diagnostic test feature that enables you to force the output high, independent of the temperature.

TI provides a broad portfolio of temperature switches and thermistors like the TMP303, TMP390 and TMP61. The TMP303 uses a window comparator and offers design flexibility through an extra-small footprint (small outline transistor-563), low power (5  $\mu$ A maximum) and supply-voltage capability as low as 1.4 V. No additional components are required for operation and the window comparator can function independently of microprocessors or microcontrollers. Seven trip points are available through different device options, which are programmable at the factory to any temperature.

The TMP390, shown in **Figure 3**, is a resistor programmable dual-output temperature switch with two internal comparators and two outputs. The TMP390 is offered in the same small package, has ultra-low power (1  $\mu$ A maximum) and low supply-voltage capability (1.62 V).



**Figure 3.** TMP390 block diagram.

Both the hot and cold trip points are configurable to any desired temperature window, with hysteresis options between 5°C and 30°C using just two resistors. The separate hot and cold trip outputs generate independent warning signals to be interpreted by the microprocessor.

### 3.1.2 Protecting your battery isn't as hard as you think

When it comes to any type of protection, the solution should be simple. Protection should be something that you design and set up once and don't worry about again; at least that's how it should be. But when it comes to more and better battery protection, you might worry about what it might cost them going forward.

Given that battery protection circuitry usually sits inside of battery packs out of sight, it isn't typically considered a cool, sleek new application feature, and you may not give it much thought. But battery protection can cause major headlines if not done properly.

For any protection device, you want the setup to be simple: an integrated circuit that protects your system but does not come with a high current consumption. The TI BQ77905 family of battery protectors for three- to five-series cells and beyond can help by providing the protection your system needs with low power drain.

In battery applications, you always need to have a primary protector that will serve as the first line of defense; any protection after will have the role of secondary protection. Secondary protection is a last-resort type of battery protection that is usually simple overvoltage protection, like BQ7718 family.

The BQ77905 shown in **Figure 1** is a primary protector for applications such as power tools; garden tools; vacuums; and robotic applications like drones, robotic vacuums and robotic lawnmowers. These types of industrial consumer applications take a toll on their battery packs, since consumers want their power tool or robotic vacuum to perform as if it were AC-powered. Typical continuous current consumptions for these applications can go as high as 50 A (in power tools) and as low (but still high) as 15 A (in vacuums).

In addition to supporting high current draws, the internal battery pack circuitry needs to consume ultra-low power for longer battery lifetimes and overall runtime. That is where the BQ77905's 6  $\mu$ A of average current consumption comes in handy.





**Figure 1.** BQ77905 3S to 5S advanced stackable low-power battery protector EVM.

Industrial consumer applications typically include battery-pack sizes of 3S (small power tools or drones), 4S (drones), 5S (professional power tools), 6S (industrial drones), 7S (vacuums), 10S (garden tools or larger power tools like saws)

and even 20S. To accommodate these various sizes, creating a common platform for battery-pack design eliminates the engineering costs associated with redesign and unfamiliarity between different IC architectures. The BQ77905 also offers stacking capability to provide cell-count flexibility to designs.

If additional features like cell balancing and hibernate mode are needed, upgrading to the BQ77915 may be a good choice. Cell balancing helps in high cell count applications where the application needs to prolong the pack life by keeping each individual cell appropriately balanced.

In general, protection should be straightforward, easy to use and should not cost much (power consumption, price, safety). In addition, battery protection devices should provide flexibility and enable scalable approaches to various cell counts, which help manage overall design costs. Protection should never limit what the application can do.

### 3.1.3 Position feedback-related reference designs for robotic systems

#### [1 to 4 Series Cell Li-Ion Battery Pack Manager Reference Design](#)

This reference design features the BQ40z50-R1 battery pack manager, with integrated gas gauging and protection for completely autonomous operation of 1S to 4S cell lithium-ion and lithium-polymer battery packs. The architecture enables communication between the fuel gauging processor and an internal battery charger controller through SMBus broadcast commands.

#### [High EMC Immunity RS-485 Interface Reference Design for Absolute Encoders](#)

This high electromagnetic compatibility (EMC) immunity reference design demonstrates a RS-485 transceiver for use with both the drive and with encoders such as EnDat 2.2, BiSS and Tamagawa. EMC immunity – particularly immunity against inverter switching noise – is important for position encoder feedback systems within industrial drives.

[Find more reference designs for your robot system manipulator.](#)

Contributing authors: Miguel Rios and Bryan Tristan

## Chapter 4: Sensing and vision technologies

### 4.1 TI mmWave radar sensors in robotics applications

When you conjure up an image of robots, you might envision massive machine arms with visible coils and wire harnesses along a factory floor, with welding sparks flying. These machines are very different than robots portrayed in popular culture and science fiction, which present a future where robots are ubiquitous assistants in everyday living.

Today, breakthroughs in artificial intelligence technology are driving the advancement of robotics for service robots, unmanned aerial vehicles and autonomous vehicles.





As robotic technologies advance, so do complementary sensor technologies. Much like the five senses of a human being, combining different sensing technologies offers the best results when deploying robotic systems into changing and uncontrolled environments.

#### Sensor technologies in robotics

Sensor technologies in robots include force and torque sensors, touch sensors, 1D/2D infrared (IR) range finders, 3-D time-of-flight light detection and ranging (LIDAR)

sensors, cameras, inertial measurement units (IMUs), GPS and others. One relatively new technology in robotic sensing is complementary metal-oxide semiconductor (CMOS) [millimeter-wave \(mmWave\) radar sensors](#). CMOS mmWave radar sensors enable the accurate measurement of not only the distance of objects in their field of view but also the relative velocities of any obstacles. These sensing technologies all have advantages and drawbacks, as shown in **Table 1**.

One important advantage that mmWave sensors have over vision- and LIDAR-based sensors is their immunity to environmental conditions such as rain, dust, smoke, fog or frost. Additionally, mmWave sensors can work in complete darkness or in the glare of direct sunlight. Mounted directly behind enclosure plastics without external lenses, apertures or sensor surfaces, the sensors are extremely rugged and can meet Ingress Protection (IP) 69K standards. TI's mmWave sensors are also small, lightweight and produce designs that are three times smaller and half the weight of miniature LIDAR range finders.

Sensors	Detection range	Detection angle	Range resolution	Detectable information	Bad weather	Night operation	Detection performance
mmWave 	Long	Narrow and wide	Good	Velocity, range, angle	Good	Yes	Robust and stable
Camera 	Medium	Medium	Medium	Target classification	Poor	No	Complexity to calculate object coordinates
LIDAR 	Long	Narrow and wide	Good	Velocity, range, angle	Poor	No	Poor in bad weather
Ultrasonic 	Short	Wide	Good	Range	Good	No	Short-range applications

**Table 1.** Sensor technology comparison.

### Detecting glass walls

**Figure 1** illustrates the use of glass walls and partitions in modern architecture and service robots that vacuum or mop floors, for example, and need to sense these surfaces to prevent collisions. These elements have proved difficult to detect using camera- or IR-based sensors. But mmWave sensors can detect the presence of glass walls as well as materials behind them.



**Figure 1.** Modern architecture makes extensive use of glass surfaces.

To demonstrate this capability, we set up a simple experiment using the IWR1443 single-chip 76-GHz to 81-GHz TI mmWave sensor evaluation module (EVM) with a pane of glass positioned 80 cm away. We then placed a wall panel behind the glass at a distance of 140 cm, as shown in **Figure 2**.

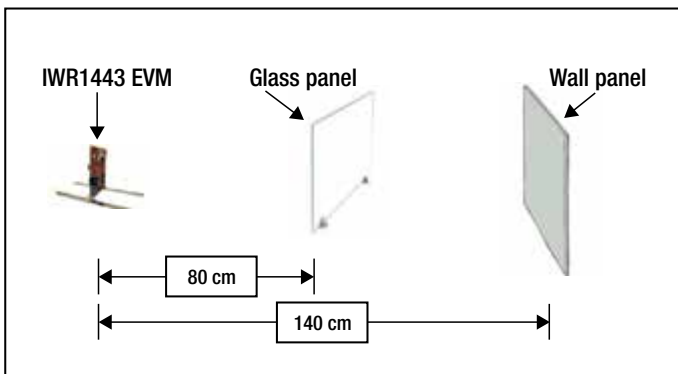

**Figure 2.** Test setup for detecting glass walls.

Using the demo software and visualization tools included with the EVM in the mmWave demo visualizer, the results shown in **Figure 3** clearly demonstrate the TI mmWave sensor detecting the glass wall surface, as well as the wall behind the glass.

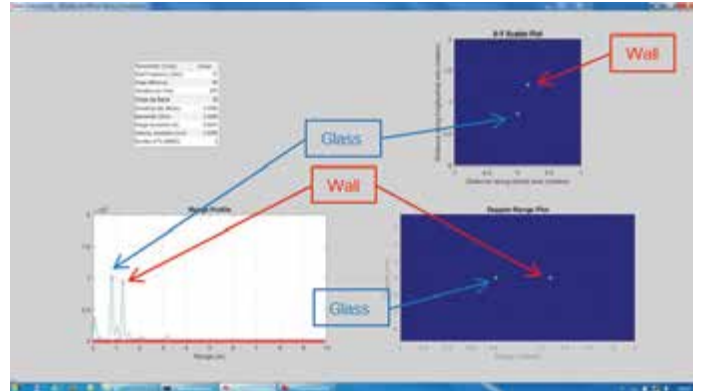

**Figure 3.** Test results showing the detection of glass and wall panel.

### Using TI mmWave sensors to measure ground speed

Accurate odometry information is essential for the autonomous movement of a robot platform. It's possible to derive odometry information simply by measuring the rotation of wheels or belts on a robot platform. This low-cost approach is easily defeated, however, if the wheels slip on surfaces such as loose gravel, dirt or wet areas.

More advanced systems can assure very accurate odometry through the addition of an IMU that's sometimes augmented with GPS. TI mmWave sensors can supply additional odometer information for robots that traverse over uneven terrain or have a lot of chassis pitch and yaw by sending chirp signals toward the ground and measuring the Doppler shift of the return signal.

**Figure 4** (next page) shows the potential configuration of a ground-speed mmWave radar sensor on a robotics platform. Whether to point the radar in front of platform (as shown) or behind the platform (as is standard practice in agriculture vehicles) is an example trade-off. If pointed in front, then you

can use the same TI mmWave sensor to also sense surface edges and avoid an unrecoverable platform loss, such as going off the shipping dock in a warehouse. If pointed behind the platform, you can mount the sensor at the platform's center of gravity in order to minimize the pitch and yaw effect on the measurement, which is a large concern in agriculture applications.

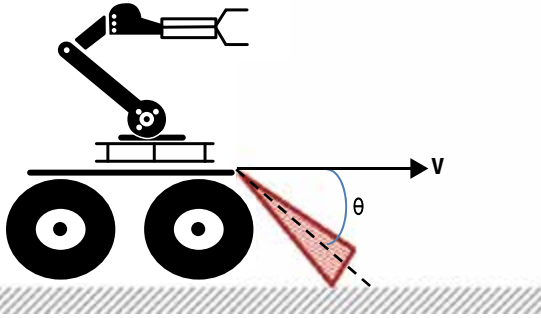

**Figure 4.** Ground-speed radar configuration on a robotics platform.

**Equation 1** calculates velocity under uniform ideal conditions.

$$fd = (2V / \lambda) \cdot \cos\theta \tag{1}$$

Expanding Equation 1 enables you to compensate for velocity-measurement errors for variables such as uneven terrain that result in sensor pitch, yaw and roll and introduce a rotational velocity component.

### Safety guards around robotic arms

As robots interact more with humans – either in service capacities or in flexible, low-quantity batch-processing automation tasks – it is critical that they do not cause harm to the people with whom they interact, as shown in **Figure 5**.

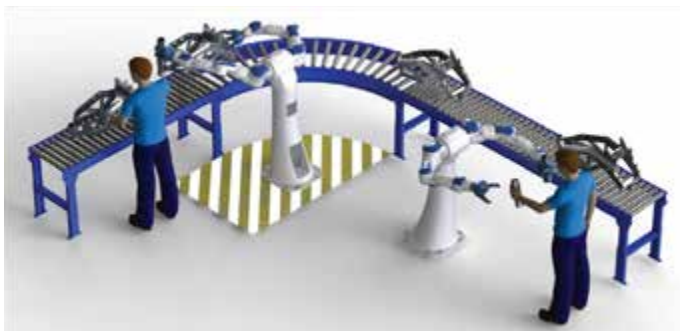

**Figure 5.** Robots of the future will be more interactive with humans.

Historically, a safety curtain or keep-out zone has been used around the robot's field of operation to ensure physical separation, as shown in **Figure 6**.



**Figure 6.** Robotic arm with a physical safety cage.

Sensors make it possible for a virtual safety curtain or bubble to separate robotic operation from unplanned human interaction, and also to avoid robot-to-robot collision as density and operation programmability increase. Vision-based safety systems require controlled lighting, which increases energy consumption, generates heat and requires maintenance. In dusty manufacturing environments such as textile or carpeting, lenses need frequent cleaning and attention.

Since TI mmWave sensors are robust at detecting objects regardless of lighting, humidity, smoke and dust on the factory floor, they are a good fit to replace vision systems, and can provide this detection with very low processing latency – typically under 2 ms. With a wide field of view and long detection range, mounting these sensors above the area of operation simplifies installation. The ability to detect multiple objects or humans with only one mmWave sensor reduces the number of sensors required and reduces cost.

### Point-cloud information generated by mmWave sensors

TI mmWave radar sensors convert radio-frequency (RF) front-end analog data to a digital representation through an analog-to-digital converter. This digitally converted data requires high-speed external data buses to bring the data stream to the processing chain, where a series of mathematical operations generate the range, velocity and angular information for points detected in the sensor's field of view. Because these systems are traditionally large and



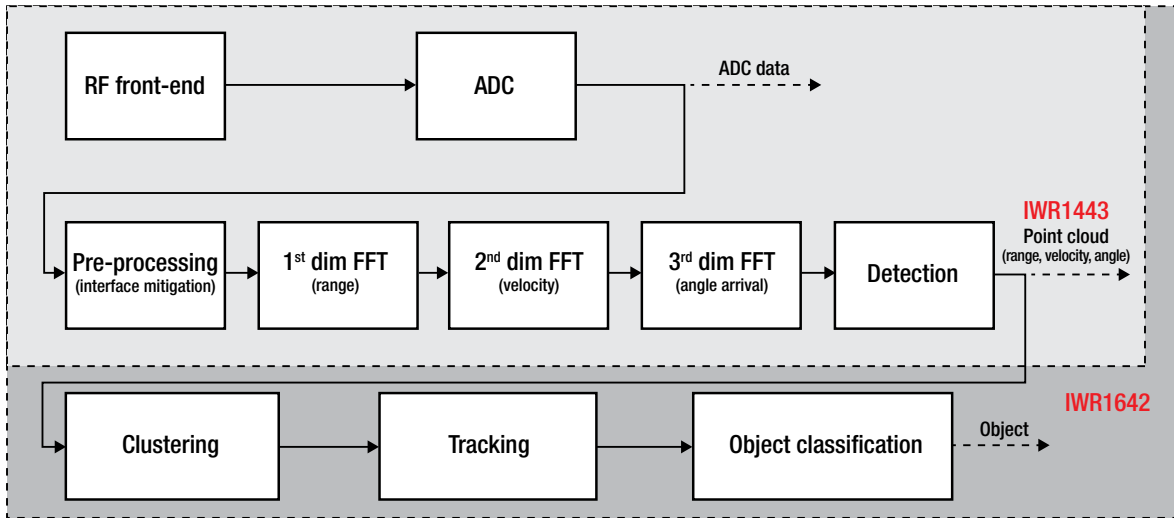

Figure 7. TI mmWave sensors processing chain.

expensive, TI sought to integrate all of this functionality onto a single monolithic piece of CMOS silicon, thus reducing size, cost and power consumption. The additional digital processing resources now handle data post-processing for such tasks as clustering, tracking and classification, as shown in **Figure 7**.

A person walking in front of a TI mmWave sensor generates multiple reflection points. Each of these detected points can be mapped in a 3D field relative to the sensor (as shown in **Figure 8**) within the robot operating system (ROS) visualization (RVIZ) tool. This mapping collects all points over a quarter-of-a-second time period. The density of the point information collected provides a good amount of fidelity with leg and arm movement visible, enabling object classification as a moving person. The clarity of the open spaces in the 3D field is also very important data for mobile robots so that they can operate autonomously.

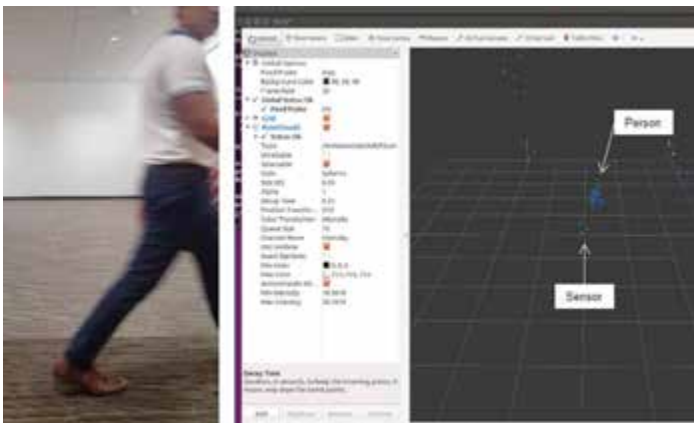

Figure 8. Point cloud of a person shown in RVIZ, captured with the IWR1443 EVM.

### Mapping and navigation using TI mmWave sensors

Using the point information for objects detected by the [IWR1443 EVM](#), it is then possible to demonstrate the use of TI mmWave radar to accurately map obstacles in a room, and to use the free space identified for autonomous operation. In order to quickly demonstrate the use of a single mmWave radar in mapping and navigation applications, we chose the Robot OS robotic open-source Turtlebot 2 development platform and mounted the IWR1443 EVM on it, as shown in **Figure 9**.



Figure 9. IWR1443 EVM mounted on a Turtlebot 2.

Implementing a basic driver for the EVM (ti\_mmwave\_ropkg), we integrated the point-cloud information into the navigation stack using the OctoMap and move\_base libraries, as shown in **Figure 10** (next page).



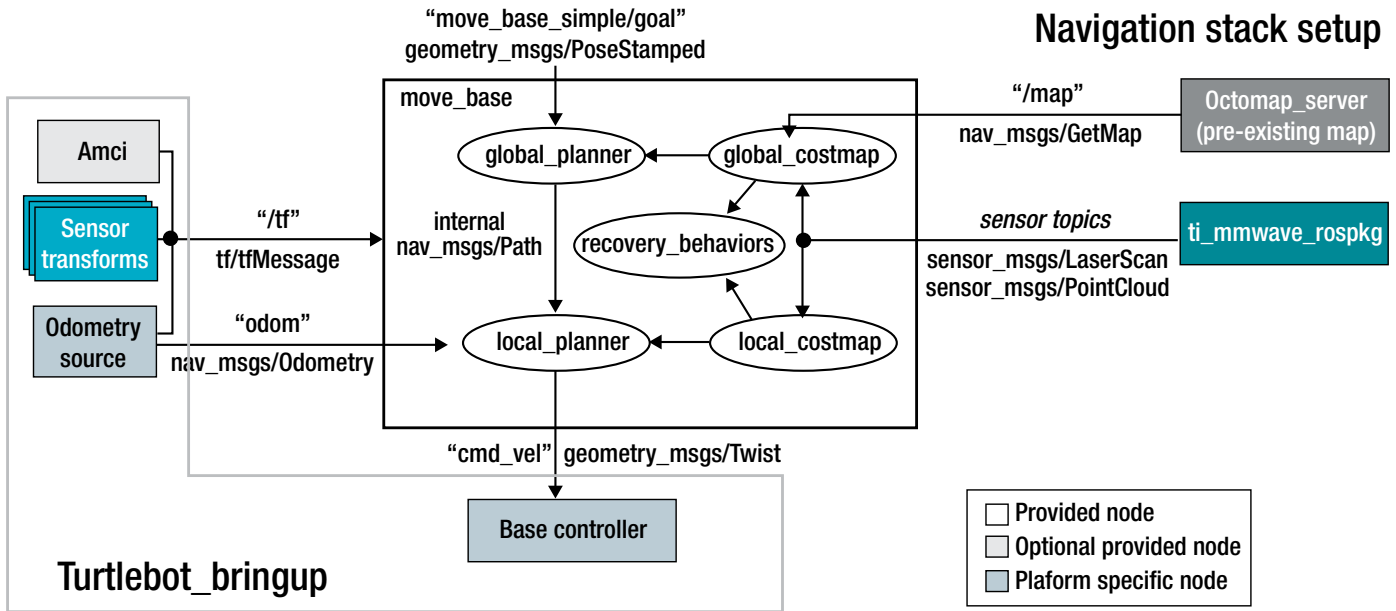

Figure 10. Robot OS library navigation stack used with the IWR1443 EVM-equipped Turtlebot 2.

We placed obstacles in an interior office environment and drove the Turtlebot 2 through the area to build a 3D occupancy grid map using the OctoMap library. Figure 11 is a screen shot of the occupancy grid using RVIZ.

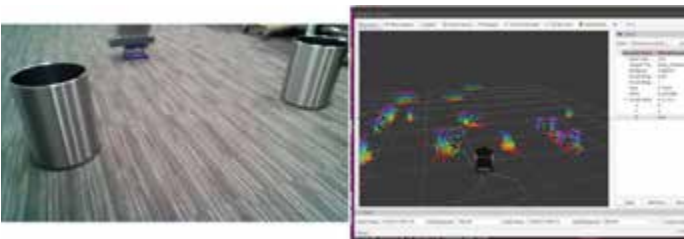

Figure 11. Generating an occupancy map using the OctoMap library in Robot OS.

We used the map generated from OctoMap with move\_base, inputting a final destination and pose position as shown by the green arrow in the screen capture of Figure 12. The Turtlebot 2 successfully and efficiently navigated to the selected spot and then rotated to the appropriate pose, avoiding both static and dynamic objects in its path. This demonstrated the efficacy of using a single forward-facing mmWave sensor for basic autonomous robotic navigation quickly in the Robot OS environment.

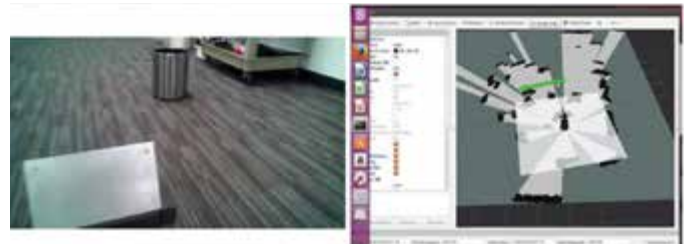

Figure 12. Using the IWR1443 EVM occupancy map for autonomous navigation of a Turtlebot 2 with the Robot OS move\_base library.

### Conclusion

TI mmWave sensors were initially expensive and large, and required multiple discrete components. Now, however, driven by TI's integration of RF, processing and memory resources onto a single monolithic CMOS die, it is now realistic to say that mmWave sensors will complement or displace established sensing technologies in robotics.

Here are the advantages of TI mmWave sensors vs. other technologies:

- TI mmWave sensors are not sensitive to environmental conditions such as direct sunlight, shadows or light reflections off of water.
- TI mmWave technology can detect glass walls, partitions and furnishings where light-based sensing solutions could fail.

- TI mmWave sensors provide Doppler velocity information on objects, and thus can help augment robot odometry where wheel slippage on wet surfaces is possible.
- TI mmWave sensors are less mechanically complex, and thus reduce manufacturing alignment and error-calibration processes. Without apertures or lenses, they are mountable directly behind enclosure plastics. Integrated calibration means less in-line manufacturing complexity. Wide field-of-view possibilities eliminate the need for mechanical rotating sensor mechanisms.
- Integrated single monolithic CMOS TI mmWave sensors enable all processing to occur within the sensor. This lowers BOM costs, makes for a small sensor and reduces the million instructions per second (MIPS) needed from the central controller processor vs. vision-based systems.

TI mmWave sensor technology enhances the intelligent operation of robotics while increasing robustness in real-world environments. The application of this technology will further accelerate the rapid adoption of robotic systems.

## 4.2 Intelligence at the edge powers autonomous factories

A variety of robots, from traditional industrial robotic systems to today's latest collaborative robots, rely on sensors that generate and process large volumes of highly varied data. This data facilitates real-time decision-making in autonomous robots, resulting in smarter incident management while maintaining productivity in dynamic real-world environments, as shown in **Figure 1**.

### How TI mmWave sensors enable intelligence at the edge in factories

Texas Instruments mmWave sensors have an integrated processor that can process data on-chip for real-time decision-making. This integration enables smaller designs compared to some light- or vision-based sensors.



**Figure 1.** mmWave sensing helps monitor the area around machinery for real-time incident management.

Additionally, having the ability to detect multiple objects and process data with only a single sensor reduces overall system costs.

Immunity to environmental conditions such as dust, smoke and variable lighting is another important consideration in a factory setting. TI mmWave sensors can operate in any of these conditions – and be mounted behind enclosure plastics – without the need for external lenses, apertures or sensor surfaces. All of these attributes enable mmWave sensors to perform well in industrial sensing applications.

TI mmWave technology enables more than just distance measurement

Intelligent edge processing allows factory machines and robots to interact with humans and reduce incidents. For instance, TI mmWave sensors can be configured to monitor a specific area of interest around machinery, define keep-out zones and trigger a warning to people in the area. These zones can be partitioned so that the sensor can react accordingly based on zone occupancy or proximity of a person.



**Figure 2.** A person walks slowly past a machine and the danger signal flashes at 1 m.

**Figure 2** illustrates this feature, with zones marked safe (green), warning (yellow) and danger (red) to indicate proximity to the machine.

TI mmWave sensors enable the accurate measurement of not only the distance of objects in their field of view, but also of the relative velocities of any obstacles. This enables robots to

take more predictive action, such as stopping the machine, based on how fast objects are approaching the sensor.

**Figure 3** shows how quickly the machine triggers a danger-zone warning based on the speed of the person approaching the machine.

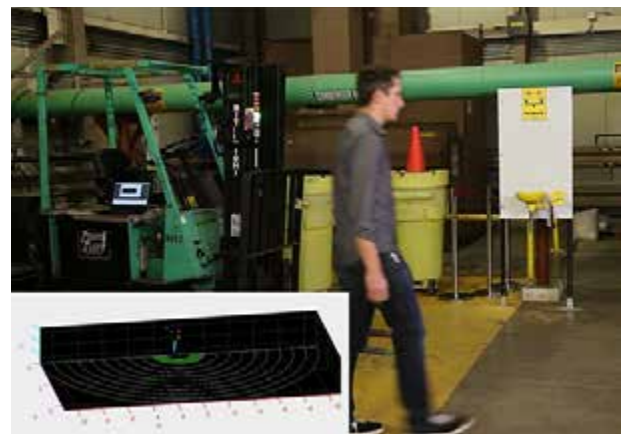

**Figure 3.** The danger sign triggers at 1 m when a person is walking slowly (a); and at 2 m when a person is walking fast (b).

To improve productivity, you want the machine to avoid stops due to false triggers. The example in **Figure 4** shows how integrated tracking algorithms enable the sensor to accurately determine a person's direction. When a person is walking away from the machine, it does not turn on a warning signal and takes no other action.

### Simplify design and speed development

To simplify the design of robotic systems and reduce development time, the Area scanner using mmWave sensor with integrated antenna-on-package reference design uses the IWR6843 EVM, which works on the 60-GHz frequency band and integrates a complete radar processing chain onto the device.



**Figure 4.** The sensor does not indicate a danger signal, since the person is walking away from the machine.



### 4.3 Use ultrasonic sensing for graceful robots

We're not far from the day when robots perform many of the tasks done by humans today. We already have robotic vacuums cleaning our homes and robotic mowers cutting the grass in our yards. On factory floors, robots are building many of the products we use, from toothbrushes to cars. Robots are serving food in China and Japan, while drones are fertilizing farms and delivering goods.

So it won't be long until robots will build our homes, lay our roads and drive us around. But one of the key requirements for the reality of such a future is for robots to have senses similar to humans.

One of the biggest challenges with robotic devices is how they find their way around without crashing into walls, furniture, equipment, humans or other robots. To avoid obstructions and do their job effectively, a robot should be able to detect obstacles from a few feet to a few centimeters away so that they have time to navigate elsewhere.

Common technologies for detecting obstacles include:

- Ultrasonic sensing, which transmits ultrasonic waves and listens for the echoes that reflect back from any obstacles.
- Optical time-of-flight (ToF) sensors, which use a photodiode to capture reflected light waves from obstacles.
- Radar sensors, which use radio-frequency waves and the returning echoes from objects to determine the direction and distance of a moving object.

The first technology, ultrasonic sensing, is a low-cost, slower-speed alternative to radar for robots that don't need to reach high speeds in homes and factories. Ultrasonic sensing is more reliable than optical ToF sensing for obstacle avoidance, as ultrasonic sensing is not affected by the amount of available light reflected off of obstacles. Another benefit of ultrasonic sensing is its ability to sense glass or any other transparent surface, since it uses sound waves instead of light to detect objects.

#### Many applications for robotics

Consider a robot vacuum that either on command or following a set schedule leaves its base and moves around a home to clean the floors. A good way to design this system

would be to use ultrasonic sensors embedded on the sides of the vacuum to give it full 360-degree coverage. The spacing and number of sensors would depend on the shape of the vacuum and the field of view (FOV) of the ultrasonic sensor.

As the robot vacuum moves around, the ultrasonic sensor network maps obstructions, calculates the distance from them and feeds this information to the central processing unit (CPU) to navigate around them. A similar approach with integrated ultrasonic sensors would work for robot lawn mowers, robot interactive toys, or restaurant or retail service robots, as shown in **Figure 1**.



**Figure 1.** Examples of service robots.

As a second example, consider assembly-line robots and robots that move raw materials or finished goods within and between a factory floor and a warehouse.

In today's factories, robot arms assemble products by moving around to pick up and place parts and install nuts and bolts, as shown in Figure 2. A main concern among factory owners and robotic system manufacturers is installing sensors on robotic arms to prevent collisions between multiple robots on the floor. Ultrasonic sensors installed in appropriate locations on robotic arms or mobile robotic vehicles can provide intelligence about objects nearby, along with distance information that the CPUs of these robotic systems can use to avoid collisions.



**Figure 2.** Assembly line robotic system components.

The components of an ultrasonic-based obstruction avoidance system used in robots would include:

- **Ultrasonic transducers.** These are piezoelectric crystals that oscillate to generate ultrasonic sound waves when an AC voltage is applied, and vice versa when the echo returns. There are two types of transducers: closed top, where the piezoelectric crystal is hermetically sealed (protecting it from the environment); and open top, where the crystal is exposed or covered by something similar to a speaker mesh. Closed-top transducers require a higher drive voltage that necessitates an additional system component: a transformer.
- **A transformer.** A single-ended or center-tap transformer will generate the large voltage needed to drive closed-top transducers.
- **An ultrasonic signal processor and transducer driver.** As an example, TI's [PGA460](#) drives the transformer, processes the returned electrical signals from the echoes and calculates the ToF data for each of the relevant echoes in real time.

- **A CPU.** This section of a robotic system uses the ToF information from multiple ultrasonic sensors around the robot to map obstructions and either stop or help navigate away from them, depending on its programming.

**Figure 3** is an example of an ultrasonic transceiver module that combines an ultrasonic transducer and the TI's PGA460 ultrasonic signal processor and driver IC. The design files for the module are available as a reference.

### Get started with ultrasonic sensing

Ultrasonic sensing is a cost-effective, reliable and practical solution for home and factory robotic systems. TI offers a few different devices and a wide variety of collateral to help you [quickly develop a design based on ultrasonic sensing](#).

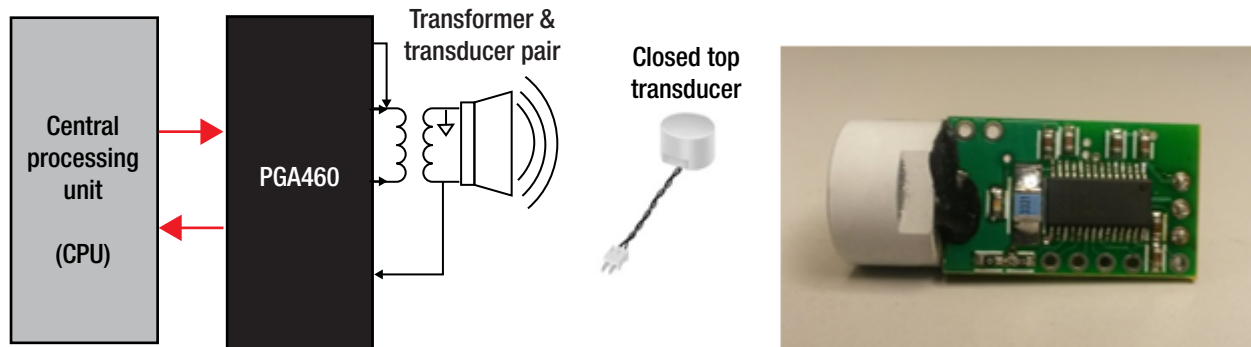

**Figure 3.** Ultrasonic transceiver module example.

## 4.4 How sensor data is powering AI in robotics

From traditional industrial robotic systems to today's latest collaborative robots (cobots), robots rely on sensors that generate increasingly massive volumes of highly varied data.

This data can help build better machine learning (ML) and artificial intelligence (AI) models that robots rely on to become autonomous, making real-time decisions and navigating in dynamic real-world environments.

Industrial robots are typically placed in caged environments, and will stop when a human enters its environment. But limiting human/robot collaboration prevents the realization of many benefits. Autonomous capabilities would enable their safe and productive co-existence of humans and robots.

Sensing and intelligent perception in robotic applications are important, because the effective performance of robotic systems – particularly ML/AI systems – greatly depends on the performance of sensors that provide critical data to these systems. Today's wide range of increasingly sophisticated and accurate sensors, combined with systems that can fuse all of this sensor data together, are enabling robots to have increasingly good perception and awareness. Examples of sensing abilities in robotics can be seen in **Figure 1**.

### The growth of AI

Robotic automation has been a revolutionary technology in the manufacturing sector for some time, yet the integration of AI into robotics is poised to transform the industry over the next few years.

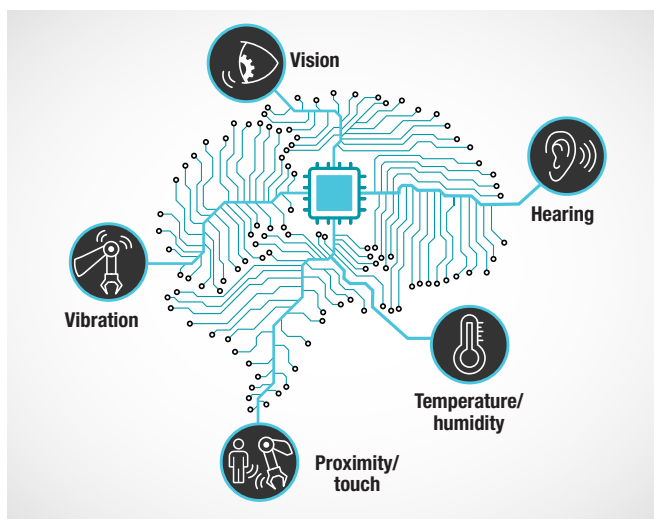

**Figure 1.** The different senses of a robot.

What are some of today's key trends in robotics and automation? What technologies will tie AI to the data that it needs to be intelligent? And finally, how are TI's sensors being used (and fused) into AI systems?

### Pushing AI processing for robotics to the edge

There are two main parts of ML: training and inference, which can be executed on completely different processing platforms. The training side usually occurs offline on desktops or in the cloud, and entails feeding large data sets into a neural network. Real-time performance or power is not an issue during this phase. The result of the training phase is a trained AI system that when deployed can perform a specific task, such as inspecting a bottle on an assembly line, counting and tracking people within a room, or determining whether a bill is counterfeit.

But in order for AI to fulfill its promise in many industries, the fusion of sensor data that happens during inference (the part that executes the trained ML algorithm) must happen in (near) real time. So ML and deep-learning models must be on the edge, deploying the inference into an embedded system.

Say that a cobot is built to work in close collaboration with humans. It relies on data from proximity sensors as well as vision sensors to ensure that it successfully protects humans from harm while supporting them in activities that would be challenging for them. All of this data needs to be processed in real time, but the cloud is not fast enough for the real-time, low-latency response that the cobot needs. To address this bottleneck, today's advanced AI systems are pushed to the edge, which in the case of robots means onboard.

### The decentralized AI model

A decentralized AI model relies on highly integrated processors that have:

- A rich peripheral set for interfacing to various sensors.
- High-performance processing capability to run machine-vision algorithms.
- A way to accelerate deep learning inference.

All of these capabilities also have to work efficiently and with a relatively low-power and small-size footprint in order to exist at the edge.



Power- and size-optimized “inference engines” are increasingly available as ML grows in popularity. These engines are specialized hardware offerings aimed specifically at performing ML inference.

An integrated SoC is often a good choice in the embedded space, because in addition to housing various processing elements capable of running deep learning inference, an SoC also integrates many components necessary to cover the entire embedded application. Some integrated SoCs include display, graphics, video acceleration and industrial networking capabilities, enabling a single-chip solution that does more than just run ML/AI.

[Sitara™ AM57x processors](#) are good examples of processors running AI at the edge. These processors have multiple high-speed peripherals for interfacing to multiple sensors – like video, ToF, LIDAR and mmWave sensors – as well as dedicated hardware in the form of C66x digital signal processor cores and embedded vision engine subsystems to accelerate AI algorithms and deep learning inference.

Let’s look at some of the top robotic trends today.

### Cobots

Humans can’t generally get near traditional industrial robots while they are operating without placing themselves in peril. Cobots are, in contrast, designed to operate safely alongside humans as shown in **Figure 2**, moving slowly and gracefully.

As defined by International Organization for Standardization TS 15066, a cobot is a robot capable of being used in a collaborative operations where robots and humans work concurrently within a defined workspace for production operation (this excludes robot-plus-robot systems or co-located humans and robots, which are operating at different times). Defining and deploying cobots to foresee potential collisions between physical portions of the robot (or virtual extensions like lasers) and the operators makes the use of sensors to determine the exact position and velocity of the operator more important.

Cobot makers must implement a high level of environmental sensing and redundancy into robot systems to quickly detect and prevent possible collisions. Integrated sensors connected to a control unit will sense an impending collision between a robot arm and a human or other object, and the control unit will turn the robot off immediately. If any sensor or its electronic circuit fails, the robot also turns off.

As cobots become more capable in demanding industrial environments, manufacturers will increasingly add them to the factory floor, particularly those manufacturers with strict return-on-investment objectives and a desire to improve product cycle times.

### Logistics robots

Logistics robots are mobile units that operate in environments where people may or may not be present, such as warehouses, distribution centers, ports or campuses. Logistics robots fetch goods and bring them to a packing station, or transport goods from one building of a company site to another; some are capable of picking and packing goods as well. These robots typically move within a particular environment and need sensors for localization, mapping and to prevent collisions (especially with humans).

Until recently, most logistics robots used pre-defined routes; they are now capable of adjusting their navigation based on the location of other robots, humans and packages. Ultrasonic, infrared and LIDAR sensing are all enabling technologies. Because of the robot’s mobility, the control unit is located inside, often with wireless communication to a central remote control. Logistics robots are now adopting advanced technologies such as ML logic, human-machine collaboration and environmental analysis technologies.



**Figure 2.** Cobots working alongside humans in a factory environment.

Rising labor costs and stringent government regulations are contributing to the higher adoption of logistics robots. Their popularity is also rising because of a decrease in the cost of equipment, components like sensors, and the cost of (and time required) for integration.

## Last-mile delivery robots

In a product's journey from warehouse shelf to customer doorstep, the last mile of delivery is the final step of the process: the point at which the package finally arrives at the buyer's door. In addition to being key to customer satisfaction, last-mile delivery is expensive and time-consuming.

Last-mile delivery costs represent a substantial percentage of the total shipping cost: 53% overall. As such, making the last mile of delivery more efficient has become a focus for where to develop and implement new robotics technologies that can drive process improvements and increased efficiency.

## ToF optical sensors

These sensors rely on the principle of ToF and use a photodiode (a single sensor element or an array) along with active illumination to measure distance. The reflected light waves from obstacles are compared with the transmitted wave to measure the delay, which in turn is a representation of distance. This data then helps create a 3D map of the object.

TI's ToF chipsets enable ToF-based sensing that goes beyond proximity detection to enable next-generation machine vision. The chipsets allow for maximum flexibility to customize designs for robot vision and other applications, with tools that include an evaluation module and a highly configurable camera development kit, which provides a 3D location of each pixel for accurate depth maps that aid customization. Discrete solutions leverage topologies and semiconductor technologies such as time-to-digital converter and GaN, as demonstrated in the [LIDAR Pulsed Time of Flight Reference Design](#) and the [Nanosecond Laser Driver Reference Design for LIDAR](#).

A 3D ToF sensor like TI's [OPT8320](#) enables robots to determine the exact angle of a screw and then fine-tune the screwdriver so that screws consistently align without human intervention. A ToF-based analog front end like the OPT3101 can help identify the distance of a robotic arm to a target and help in accurate positioning.

For higher-resolution 3D sensing, flexible structured lighting – as enabled with DLP® technology and demonstrated in the [3D Machine Vision Reference Design Based on AM572x Processor with DLP Structured Light](#) – can help bring resolutions to micrometers or below.

## Temperature and humidity sensors

Many robots need to measure the temperature and sometimes the humidity of both their environment and their components – including motors and main AI motherboards – to ensure that they are operating in safe ranges. This is especially important for robots, because when a motor is under a heavy load, it can draw a lot of power and heat up.

Accurate temperature monitoring protects motors, while better temperature accuracy enables motors to be driven harder before hitting safety margin limits. In addition, just about every other sensor is sensitive to temperature and benefits from thermal compensation. By knowing the temperature, you can correct for the temperature drift of other sensors to get more accurate measurements.

In equatorial factories and in tropical climate zones, temperature and humidity sensors can predict dew points for electronic system protections and predictive maintenance.

## Ultrasonic sensors

Vision sensors may not work if the robot is blinded by a bright light or finds itself in a very dark environment. By transmitting ultrasonic waves and listening for echoes that reflect back from objects (similar to how bats maneuver), ultrasonic sensors perform excellently in dark or bright conditions, overcoming the limitations of optical sensors.

Ultrasonic sensing is a low-cost, slower-speed alternative to radar for robots that don't need to reach high speeds. Ultrasonic sensing is more reliable than optical ToF for obstacle avoidance, as ultrasonic sensing is not affected by the amount of available light reflected off of obstacles. For example, ultrasonic sensing provides the ability to sense glass or other transparent surfaces because it uses sound waves rather than light to detect objects.

## Vibration sensors

Industrial vibration sensing is a crucial part of the condition monitoring necessary for predictive maintenance. Integrated electronic piezoelectric sensors are the most common vibration sensor used in industrial environments.

Vibration sensors enable robots to be aware if some of its mechanics are damaged or aged, facilitating preventive maintenance before operations become endangered. Using AI/ML can take the accuracy of these predictions to the next level.

### mmWave sensors

mmWave sensors use radio waves (**Figure 3**) and their echoes to determine the direction and distance of a moving object by measuring three components: velocity, angle and range. This enables robots to take more predictive actions based on how fast objects are approaching the sensor. Radar sensors deliver excellent performance in the dark and can sense through materials like drywall, plastic and glass.

As stated in the white paper “TI mmWave radar sensors in robotic applications,” CMOS mmWave radar sensors enable the highly accurate measurement of not only the distance of objects in their field of view, but also the relative velocities of any obstacles.

Complementary metal-oxide semiconductor (CMOS) mmWave radar sensors enable the highly accurate measurement of not only the distance of objects in their field of view, but also the relative velocities of any obstacles.

TI’s highly integrated single-chip mmWave radar sensors are small, lightweight and enable real-time processing to occur within the sensor edge, often removing the need for additional processors.

mmWave technology enables designs that are three times smaller and half the weight of miniature LIDAR range finders. This lowers BOM costs, makes for a small sensor, and reduces the million instructions per second needed from the central controller processor versus vision-based systems. Mounted directly behind enclosure plastics without external lenses, apertures or sensor surfaces, the sensors are extremely rugged and can meet the Ingress Protection 69K standard.

mmWave sensors were initially expensive and large, and required multiple discrete components. Now, however, driven by TI’s integration of radio-frequency, processing and memory resources onto a single monolithic CMOS die, it is reasonable to say that mmWave sensors will complement or displace established sensing technologies in robotics over the coming years.

More advanced radar sensing systems can ensure very accurate odometry through the addition of an inertial measurement unit that’s sometimes augmented with GPS. mmWave sensors can supply additional odometer information for robots that traverse over uneven terrain or have a lot of chassis pitch and yaw by sending chirp signals toward the ground and measuring the Doppler shift of the return signal.

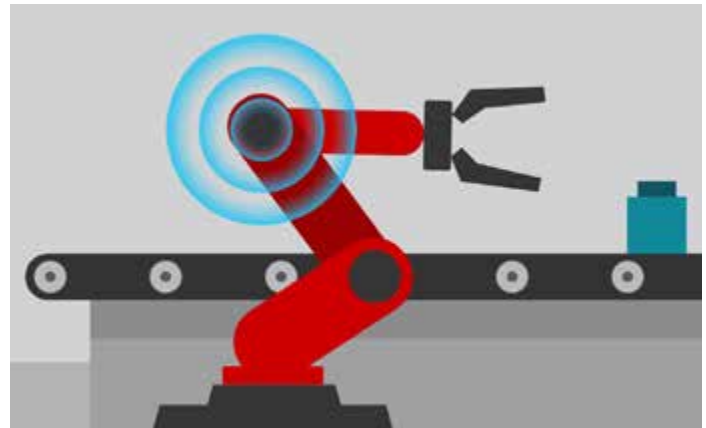

**Figure 3.** Robotic arm using mmWave sensors.

### TI solutions for the entire AI robotics signal chain

The signal chain for adaptive, self-learning AI robotic systems requires a fusion of diverse sensor data in real time. The sensors of a cobot are in some ways like the five human senses, and all of our senses are critical for fully autonomous operation. Each of our senses use different parts of the brain and different amounts of the brain’s processing. For example, vision requires more brain power than hearing or smelling.

Analogously, robots will have more and more sensors connected to AI and ML systems that run inside the robot, with the key challenge for AI robotic system manufacturers being the need to address multiple AI systems running and communicating together for a hybrid ML system driven by data from hybrid sensors.

Robot developers depend on advanced IC solutions to minimize the headaches of circuit design and certification, speeding the development of products that they can deliver to industrial customers quickly. The ICs that enable advances in industrial robots must provide precise sensing, high-speed sensor signal conversion, fast computation/signal processing for real-time response and high-speed communications. ICs also enable high-efficiency and small-form-factor power supplies in conjunction with advanced semiconductors like GaN FETs. New ICs also bring new standards to the industry, such as single twisted-pair Ethernet and power over single-twisted pair, which reduces cabling complexity and enhances reliability.

TI can provide everything from the sensors to the processors needed for next-generation robotics, with a broad product and solutions portfolio that spans the entire AI robotics signal chain. From sensor input to actuator or motor output, from individual equipment units to factory-level control and beyond, TI solutions handle the signal chain as well as the processing and power required for robotic applications. Products include features like reinforced isolation and are tested and qualified for use in harsh industrial environments.

### 4.5 Bringing machine learning to embedded systems

It is hard to understate the promise of machine learning, the latest evolution of which, deep learning, has been called a foundational technology that will impact the world to the same degree as the internet, or the transistor before that.

Brought on by great advancements in computing power and the availability of enormous labeled data sets, deep learning has already brought major improvements to image classification, virtual assistants and game playing, and will likely do the same for countless industries. Compared to traditional machine learning, deep learning can provide improved accuracy, greater versatility and better utilization of big data – all with less required domain expertise.

In order for machine learning to fulfill its promise in many industries, it is necessary to deploy the inference (the part that executes the trained machine learning algorithm) into an embedded system. This deployment has its own unique set of challenges and requirements.

### Training and inference

The two main pieces of deep learning, training and inference, can be executed on completely different processing platforms, as shown in **Figure 1**. The training side of deep learning usually occurs offline on desktops or in the cloud and entails feeding large labeled data sets into a deep neural network (DNN). Real-time performance or power is not an issue during this phase.

As stated in the white paper, [How sensor data is powering AI in robotics](#), the result of the training phase is a trained neural network that when deployed can perform a specific task, such as inspecting a bottle on an assembly line, counting and tracking people within a room, or determining whether a bill is counterfeit.

The deployment of the trained neural network on a device that executes the algorithm is known as the inference. Given the constraints imposed by an embedded system, the neural network will often be trained on a different processing platform than the one running the inference. For the purposes of this discussion, the terms deep learning and machine learning refer to the inference.

### Machine learning at the edge

The concept of pushing computing closer to where sensors gather data is a central point of modern embedded systems – that is, the edge of the network. With deep learning, this concept becomes even more important to enable intelligence and autonomy at the edge.

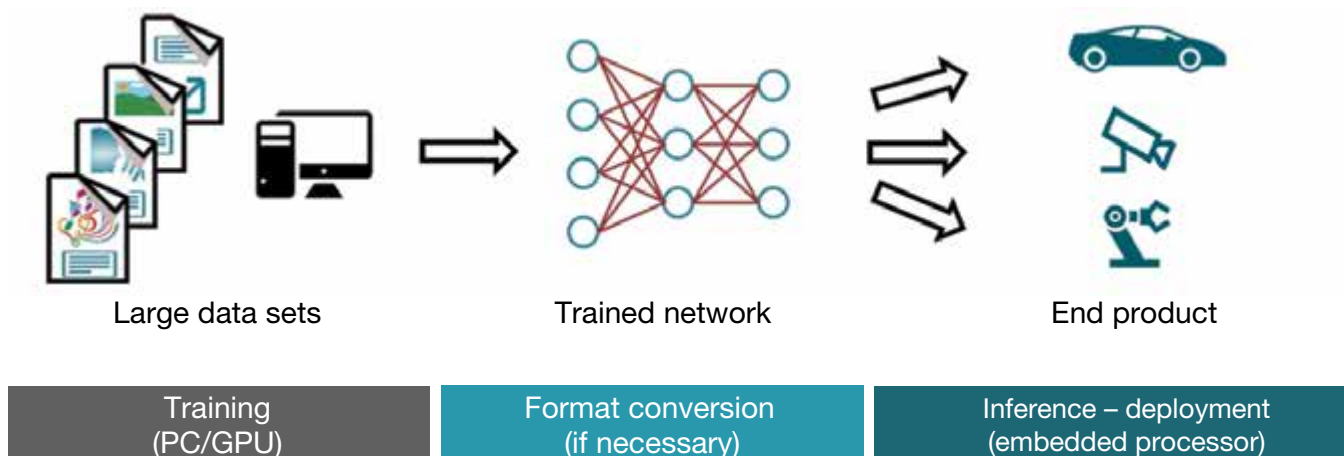

**Figure 1.** Traditional deep learning development flow.



For many applications – from automated machinery and industrial robots on a factory floor, to self-guided vacuums in the home, to an agricultural tractor in the field – the processing must happen locally.

The reasons for local processing can be quite varied depending on the application. Here are just a few of the concerns driving the need for local processing:

- **Reliability.** Relying on an internet connection is often not a viable option.
- **Low latency.** Many applications need an immediate response. An application may not be able to tolerate a time delay in sending data somewhere else for processing.
- **Privacy.** The data may be private, and therefore should not be transmitted or stored externally.
- **Bandwidth.** Network bandwidth efficiency is often a key concern. Connecting to a server for every use case is not sustainable.
- **Power.** Power is always a priority for embedded systems. Moving data consumes power. The further the data needs to travel, the more energy needed.

### Choosing an embedded processor for machine learning

Many of the concerns requiring local processing overlap with those inherent in embedded systems, particularly power and reliability. Embedded systems also have several other factors to consider that are related to or caused by the system's physical limitations. There are frequently inflexible requirements regarding size, memory, power, temperature, longevity and, of course, cost.

In the midst of balancing all of the requirements and concerns for a given embedded application, there are a few important factors to consider when choosing a processor to execute machine learning inference for the edge.

- **Consider the entire application.** One of the first things to understand before selecting a processing solution is the scope of the entire application. Will running the inference be the only processing required or will there be a combination of traditional machine vision with the addition of deep learning inference? It can often be more efficient for a system to run a traditional computer vision algorithm at a high level and then run deep learning when needed.

For example, an entire input image at high frames per second (fps) can run classical computer vision algorithms to perform object tracking with deep learning used on identified sub-regions of the image at a lower fps for object classification. In this example, the classification of objects across multiple subregions may require multiple instances of inference, or possibly even different inferences running on each sub-region. In the latter case, you must choose a processing solution that can run both traditional computer vision and deep learning, as well as multiple instances of different deep learning inferences. **Figure 2** shows an example usage of tracking multiple objects through sub-regions of an image and performing classification on each object being tracked.

- **Choose the right performance point.** Once you have a sense of the scope of the entire application, it becomes important to understand how much processing performance is necessary to satisfy the application needs. This can be difficult to understand when it comes to machine learning because so much of the performance is application-specific. For example, the performance of a convolutional neural net (CNN) that classifies objects on a video stream depends on what layers are used in the network, how deep the network is, the video's resolution, the fps requirement and how many bits are used for the network weights – to name just a few. In an embedded system, however, it is important to try and get a measure of the performance needed because throwing too powerful a processor at the problem generally comes at a trade-off against increased power, size and/or cost. Although a processor may be capable of 30fps at 1080p of ResNet-10, a popular neural net model used in high power, centralized deep learning applications, it's likely overkill for an application that will run a more embedded-friendly network on a 244 x 244 region of interest.
- **Think embedded.** Selecting the right network is just as important as selecting the right processor. Not every neural net architecture will fit on an embedded processor. Limiting models to those with fewer operations will help achieve real-time performance. You should prioritize benchmarks of an embedded-friendly network, one that will tradeoff accuracy for significant computational savings, instead of more well-known networks like AlexNet and GoogleNet, which were not designed for the embedded

space. Similarly, look for processors capable of efficiently leveraging the tools that bring these networks into the embedded space. For example, neural networks can tolerate lots of errors; using quantization is a good way to reduce performance requirements with minimal decreases in accuracy. Processors that can support dynamic quantization and efficiently leverage other tricks like sparsity (limiting the number of non-zero weights) are good choices in the embedded space.

- **Ensure ease of use.** Ease of use refers to both ease of development and ease of evaluation. As mentioned earlier, right-sizing the processor performance is an important design consideration. The best way to do this correctly is to run the chosen network on an existing processor. Some offerings provide tools that, given a network topology, will show achievable performance and accuracy on a given processor, thus enabling a performance evaluation without the need for actual hardware or finalization of a network. For development, being able to easily import a trained network model from popular frameworks like Caffe or TensorFlow Lite is a must.



**Figure 2.** Example of object classification using embedded deep learning.

Additionally, support for open ecosystems like the Open Neural Network eXchange will support an even larger base of frameworks for development.

There are many different types of processors to consider when choosing one for deep learning, and they all have their strengths and weaknesses. Graphics processing units (GPUs) are usually the first consideration because they are widely used during network training. Although extremely capable, GPUs have had trouble gaining traction in the embedded space given the power, size and cost constraints often found in embedded applications.

Power- and size-optimized “inference engines” are increasingly available as deep learning grows in popularity. These engines are specialized hardware offerings aimed specifically at performing deep learning inference. Some engines are optimized to the point of using 1-bit weights and can perform simple functions like key phrase detection, but optimizing this much to save power and compute processing comes with a trade-off of limited system functionality and precision. The smaller inference engines may not be powerful enough if the application needs to classify objects or perform fine-grain work.

When evaluating these engines, make sure that they are right-sized for the application. A limitation on these inference engines comes when the application needs additional processing aside from the deep learning inference. More often than not, the engine will need to exist alongside another processor in the system, functioning as a deep learning co-processor.

An integrated SoC is often a good choice in the embedded space, because in addition to housing various processing elements capable of running the deep learning inference, an SoC also integrates many components necessary to cover the entire embedded application. Some integrated SoCs include display, graphics, video acceleration and industrial networking capabilities, enabling a single-chip solution that does more than just run deep learning.



An example of a highly integrated SoC for deep learning is the [AM5729](#) device from TI, shown in **Figure 3**. The AM5729 has two Arm® Cortex®-A15 cores for system processing, two C66x digital signal processor (DSP) cores for running traditional machine vision algorithms and four embedded vision engines (EVEs) for running the inference. TI's deep learning (TIDL) software offering includes the TIDL library, which runs on either C66x DSP cores or the EVEs, enabling multiple inferences to run simultaneously on the device. Additionally, the AM5729 provides a rich peripheral

set; an industrial communications subsystem (ICSS) for implementation of factory floor protocols such as EtherCAT; and acceleration for video encoding/decoding and 3D and 2D graphics, facilitating the use of this SoC in an embedded space that also performs deep learning.

Choosing a processor for an embedded application is often the most critical component selection for a product, and this is true for many industry-changing products that will bring machine learning to the edge.

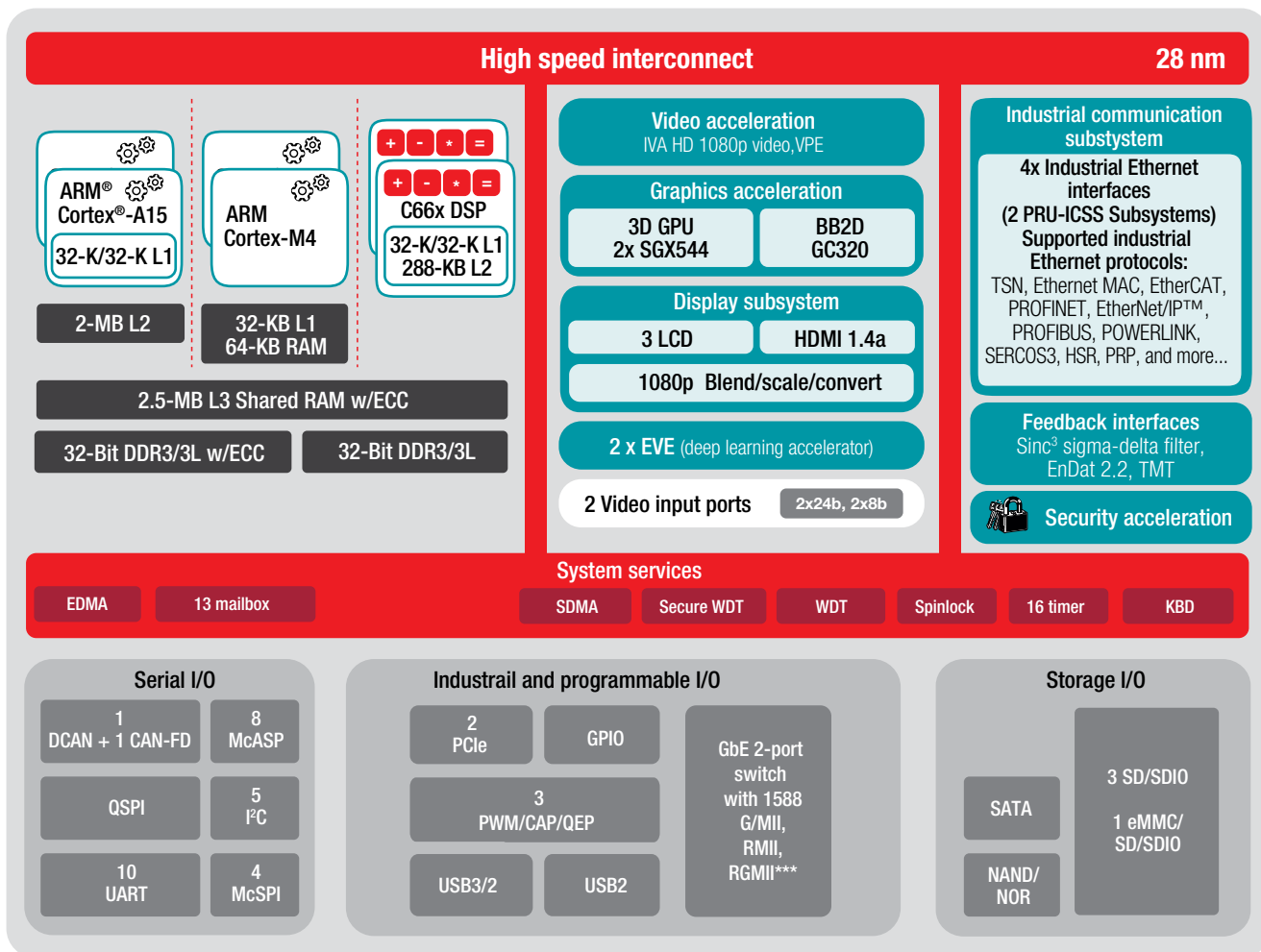

Figure 3. Block diagram of the Sitara™ AM5729 SoC.

## 4.6 Robots get wheels to address new challenges and functions

With logistics centers multiplying to keep up with the growth of online shopping, so are the numbers of wheeled robots, which handle many of the strenuous tasks in those logistics centers. The next challenge for robots on wheels will be to address the last mile of delivery to help reduce congestion in urban areas.

At the same time, human-friendly robots are starting to operate in brick and mortar shops to conduct real-time inventory, which allows supermarkets to reduce shelf space per product and increase the variety of inventory. Wheeled robots are even making an entrance into hotels to provide hospitality services ranging from check-in to room services.

It's not all serious work for these wheeled robots; they will soon be bringing pizza (as shown in **Figure 1**) or coffee to workplaces and campus dormitories. With the trend of restaurants moving to full-stack food delivery services, where one company runs all of the customer interaction management, the cooking and the logistics, wheeled robots will be in demand to deliver food sooner than later.



**Figure 1.** Example of a wheeled robot delivering pizza.

With the entrance of wheeled robots which some people consider to be robots in disguise, let's look at the whole portfolio of robots now in use in the industry:

- Industrial robots (or robot arms) handle tasks in factories like welding, palletizing, sorting and lifting. They are typically in a fixed position on the floor, ceiling or wall. They are managed by a controller placed in the base or near the robot arm.

- While the bigger industrial robots such as robotic arms have been in use for many years, mostly in the automotive industry, the smaller variants known as collaborative robots (cobots) are making a marked entrance as the opportunities of collaboration between human and robots increases.
- Logistics robots are found in warehouses, distribution centers, ports or even campuses. These robots fetch goods and bring them to a packing station, or transport goods from one building to another. These robots move within a particular environment and need a lot of sensors for localization and mapping, as well as sensors to prevent collisions.
- Hospitality robots are found in supermarkets, airports and hotels. These robots are virtual presence, welcoming and guide customers/guests (**Figure 2**).
- Inventory robots are found in supermarkets or inventory rooms. These robots scan the shelves regularly basis to ensure that the store never runs out of a product.



**Figure 2.** Example of a hospitality robot.

As mentioned in the [sensor data powering AI](#) in robotics white paper, industrial robots are typically placed in caged environments, and will stop when a human enters its environment. But limiting human/robot collaboration prevents the realization of many benefits. Autonomous capabilities would enable the safe and productive co-existence of humans and robots.

Sensing and intelligent perception in robotic applications are important, because the effective performance of robotic systems – particularly machine learning applications – greatly depends on the performance of sensors that provide critical data to these systems. Today’s wide range of increasingly sophisticated and accurate sensors, combined with systems that can fuse all of this sensor data together, are enabling robots to have increasingly good perception and awareness. Examples of these types of sensors include cameras, LIDAR, mmWave and ToF.

An application where sensing technology is especially important is in the operation of vacuum robots. A ToF sensor allows the robot to map an operational environment accurately and ensures that the robot will accomplish its task efficiently. Infrared “cliff” sensors can protect robots from falling down a flight of stairs or down steep drops.

Just as humans rely on senses and intelligence to accomplish tasks, a plethora of technologies are required to mimic what humans take for granted in robotics. TI provides solutions that address many of these technology needs, including sensing, intelligence and power.

### 4.7 Vision and sensing-technology reference designs for robotic systems

<a href="#">Area Scanner Using TI mmWave Sensor With Integrated Antenna-on-Package Reference Design</a>	This design leverages TI's single-chip mmWave technology to implement an area scanner capable of detection and localization in 3D space.
<a href="#">Autonomous Robot Reference Design Using ROS on Sitara™ MPU and Antenna-on-Package mmWave Sensors</a>	This design showcases autonomous robotics with the Linux processor software development kit (SDK) running on the Sitara AM57x processor, and the mmWave SDK running on the IWR6843 evaluation module. The design demonstrates the functionality of an embedded robotic system, where the Sitara AM57x processor running the robot operating system (ROS) processes point-cloud data from mmWave radar sensing and is the main processor for the overall system control.
<a href="#">Ultrasonic Distance Sensor with IO-link Reference Design</a>	This design features an ultrasonic distance sensor that fits in a M12 housing due to its high integration and an optimized layout. The design offers an IO-Link interface to communicate with the system control, which makes it Industry 4.0 ready.
<a href="#">LIDAR Pulsed Time of Flight Reference Design</a>	LIDAR systems use the time taken by the light to fly back and forth to an object in an effort to measure the distance to this target. This design shows how to design the time-measurement back end for LIDAR based on a time-to-digital converter (TDC), as well as an associated front end.

[Find more reference designs for your robot system.](#)

Contributing authors: Dennis Barrett, Adrian Alvarez, Prajakta Desai, Ram Sathappan, Matthieu Chevrier, Mark Nadeski and Lali Jayatilleke.

### 5.1 Achieving accuracy in bin picking with TI DLP® technology-powered structured light systems

An industrial environment handles parts of different shapes, sizes, materials, and optical properties (reflectance, absorption) every day. These parts have to be picked and placed in a specific orientation for processing, and the automation of these pick-and-place activities from an environment into containers is known as bin picking.

This task poses a challenge for a robot end effectors – devices attached to the end of a robotic arm – to know the exact 3D location, dimensions and orientation of objects it wants to grip. In order to navigate around the walls of a box and as well as other objects that might also be inside, the robot's machine vision system needs to acquire depth information in addition to 2D camera information.

A structured light technique can address challenges related to the 3D image capture of objects for bin picking. A structured light technology-based 3D scanner and camera works by projecting a series of patterns onto the object being scanned and captures the pattern distortion with a camera or sensor. A triangulation algorithm then calculates the data and outputs a 3D point cloud. Image processing software like Halcon from MVTech calculates the object's position and the robot arm's optimal approach path (**Figure 1**).

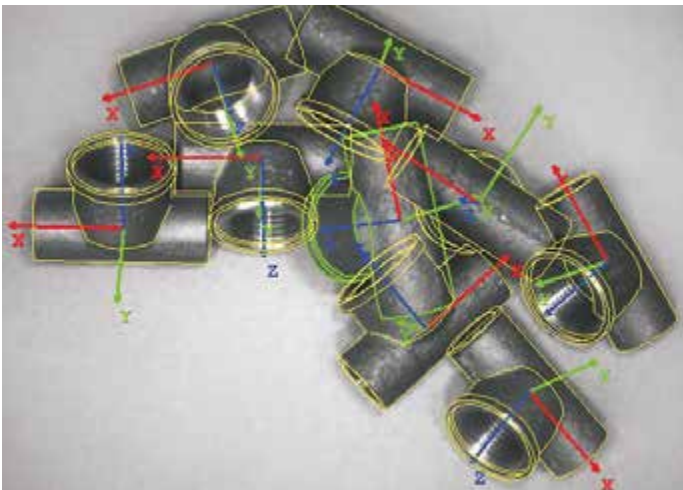

**Figure 1.** Example of matching pipe couplings with their respective 3D model (Source: Halcon by MVTech).

DLP® technology provides a high-speed pattern projection capability through a micromirror matrix assembled on top of a semiconductor chip known as a digital micromirror device (DMD), as depicted in **Figure 2**. Each pixel on a DMD represents one pixel in the projected image, enabling accurate pixel image projection. The micromirrors transition at  $\sim 3 \mu\text{s}$  to reflect the light incident on the object through a projection lens or onto a light dump. The former achieves a bright pixel on a projected scene, while the later creates a dark pixel.

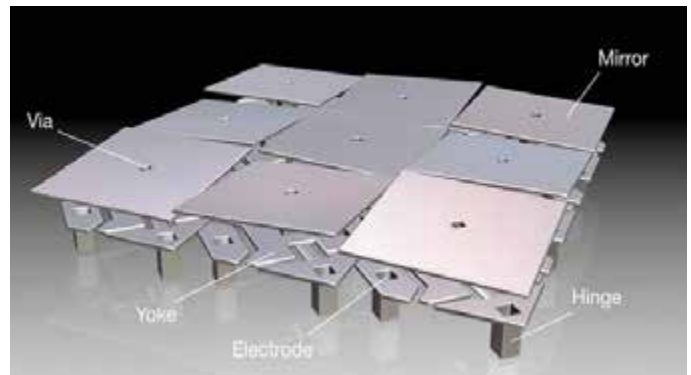

**Figure 2.** DLP chips contain millions of micromirrors that are individually controlled at high speeds and deliberately reflect light to create projected patterns.

DLP technology also offers unique advantages with its ability to project patterns over a wide wavelength range (420 nm to 2500 nm) using various light sources like lamps, LEDs and lasers.

For bin picking, DLP technology-powered structured light offers these advantages:

- **Robustness against environmental lighting.** Lighting conditions in factories (like low light exposure and high contrast between differently lit areas) or flickering light (which can interfere with machine vision systems) can be a challenge in applications that need machine vision for bin picking. DLP technology-powered structured light has inherent active lighting, which makes it robust against those conditions.
- **No moving parts.** Structured light systems capture the whole scene at once, avoiding the need to either sweep a light beam over objects or move objects through a beam (like in scanning solutions). A structured light system doesn't use moving parts at a macroscopic scale, making it immune to wear and tear through mechanical deterioration.



- **Real-time 3D image acquisition.** The micromirrors in DLP chips are controlled at high speeds and offer custom pattern projection at up to 32 kHz. DLP controllers provide trigger output and inputs for use in synchronizing cameras and other devices with the projected pattern sequence. These features help enable real-time 3D image acquisition and thus simultaneous scanning and picking.
- **High contrast and resolution of projected patterns.** Because each micromirror either reflects light onto the target or an absorption surface, it is possible to achieve high contrast ratios and enable accurate point detection independent of the object's surface properties. The availability of high-resolution DLP chips with up to 2560-by-1600-resolution mirrors means that objects down to the micron level are detectable.
- **Adaptable to object parameters.** Programmable patterns and various point-coding schemes like phase shifting or gray coding make structured light systems more adaptable to object parameters than systems using diffractive optical elements.
- **Accelerated development time.** While robots offer high repeatability, bin picking requires accuracy in an unstructured environment, where objects keep shifting position and orientation each time one is removed from a storage bin. Working successfully with this challenge requires a reliable process flow, from machine vision, to computing software, to the robot's dexterity and gripper. Making everything work in conjunction can be a challenge that consumes a lot of development time.

TI's evaluation modules for DLP technology enable fast implantation of structured light into the machine vision workflow. To demonstrate this capability, TI mounted a DLP LightCrafter™ 4500 evaluation board at a set distance and angle to a monochromatic camera. The DLP evaluation board is triggered by the camera through a trigger cable connecting the two to each other; see **Figure 3**.

Both the board and camera are connected to a PC via USB, and the whole setup is directed at a calibration board. Software from the Accurate Point Cloud Generation for 3D Machine Vision Applications Using DLP Technology reference design calibrates the camera and projector for parameters like focal length, focal point, lens distortion, translation and rotation of the camera relative to the calibration board. The reference design user guide walks through the process step by step.

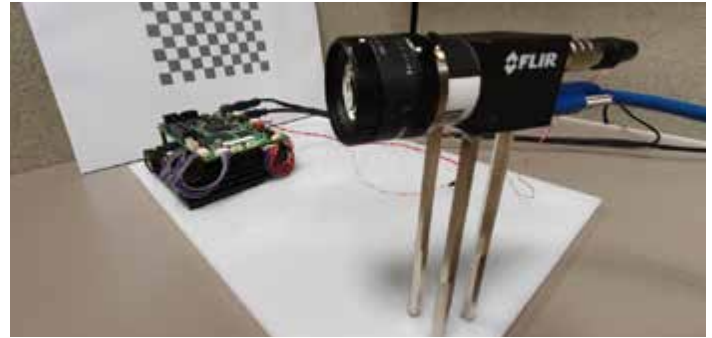
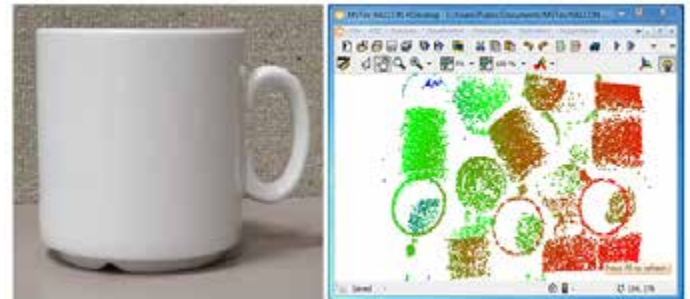

**Figure 3.** Structured light setup including the DLP® Products LightCrafter™ 4500 (left), a Point Grey forward-looking infrared Flea3 camera (right) and calibration (back).

Recalibration is only necessary if the camera is moved relative to the DLP products board.

After the setup is complete, it's possible to create point clouds of real-world targets. These clouds are output by the software in an arbitrary file format, which is then read and displayed by brief code in Halcon's HDevelop platform.

**Figure 4** shows a point cloud with color coding for depth information taken of a box filled with coffee mugs.



**Figure 4.** Captured mug (left) and acquired point cloud acquired with DLP® powered structured light of several mugs in a box displayed in Halcon HDevelop (right).

Halcon's surface matching can determine the mug's 3D pose by comparing the point cloud with a 3D computer-aided design model of a mug. The robot arm now "sees" the object, making it possible to calculate the optimal approach path of the robot arm so that it can pick objects from boxes and avoiding obstacles in an unstructured and changing environment.

Authored by: Franz Schellhase

### 6.1 Selecting the right industrial communications standard for sensors

Greater factory connectivity and control are ushering in the fourth industrial revolution, known as Industry 4.0, after the earlier revolutions of steam power, assembly lines and early automation.

This movement advances machine-to-machine communication with an exponential growth in data, bandwidth and networking, creating smart factories with more responsive automation at all levels.

Although large systems such as robots and coordinated assembly lines capture attention, the automation they enable could not be possible without sensors and actuators, which communicate with the programmable logic controllers (PLCs) that run production lines. Sensors and actuators, functioning both locally and remotely, often greatly outnumber the complex systems they support. Optimizing overall factory communications is necessary to meet the wide variety of requirements from systems of all sizes as you can see in

#### Figure 1.

Protocols adapting Ethernet to industrial usage have proven popular as field buses on the factory floor. These industrial Ethernet protocols, such as EtherCAT and Profinet, offer high bandwidth, long physical connections, low latency and deterministic data delivery, among other features required in automated manufacturing. In addition, the field networks based on these standards tie in easily to the larger plant data networks and the internet.

For sensors and actuators, however, industrial Ethernet is often excessively robust and powerful. These systems usually require point-to-point communications rather than a field bus, and their bandwidth requirements are normally low.

An innovative solution lies in IO-Link, a bidirectional communication protocol based on standard cabling and physical interconnection. IO-Link not only brings data from the factory floor to a PLC efficiently, but it also supports improved setup, diagnostics and maintenance, and is complementary to existing field-bus cabling.

Since IO-Link and industrial Ethernet are complementary, it can benefit designers of networked factory systems to understand how the two standards work together.

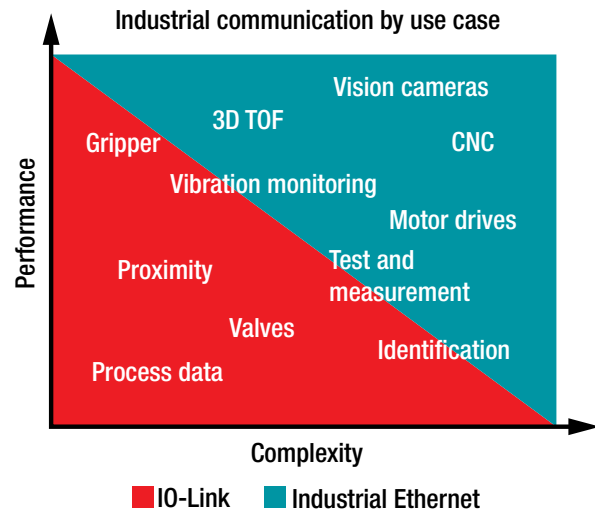

Figure 1. Industrial communication by use case.

#### IO-Link for low bandwidths

Sensors and actuators are the most basic units of automation, feeding information into and acting on instructions from networked systems. Traditionally, these devices connect to control units through interfaces that provide little intelligence, and thus exchange little or no configuration and diagnostic information. Installing a new device requires configuration by hand at the point of use, and without diagnostics, it is impossible to perform just-in-time preventive maintenance.

IO-Link (International Electrotechnical Commission [IEC] 61131-9) is an open standards protocol that addresses the need for intelligent control of small devices such as sensors and actuators. This standard provides low-speed point-to-point serial communication between a device and a master that normally serves as a gateway to a field bus and PLC. The intelligent link enables ease of communication for data exchange, configuration and diagnostics.

An unshielded three-wire cable as long as 20 meters, normally equipped with M12 connectors, establishes the IO-Link connection. Data rates range up to 230 kbps with a nonsynchronous minimum cycle time of 400  $\mu$ s, +10%. Four operating modes support bidirectional input/output (I/O), digital input, digital output and deactivation. Security mechanisms and deterministic data delivery are not specified. A profile known as the IO device description (IODD)



contains communication properties; device parameters; identification, process and diagnostic data; and information specifically about the device and manufacturer.

The many advantages of an IO-Link system include standardized wiring, increased data availability, remote monitoring and configuration, simple replacement of devices and advanced diagnostics. IO-Link permits factory managers to receive sensor updates and plan for upcoming maintenance or replacement. Swapping out a sensing or actuation unit that needs replacement and configuring a new one from the PLC through the IO-Link master eliminates manual setup and reduces downtime. Switching production remotely from one configuration to another without visiting the factory floor facilitates easier product customization (**Figure 2**). Factories can upgrade production lines readily to IO-Link, since it is backward-compatible with existing standard I/O installations and cabling. Altogether, these capabilities result in reduced overall costs, more efficient processes and greater machine availability.

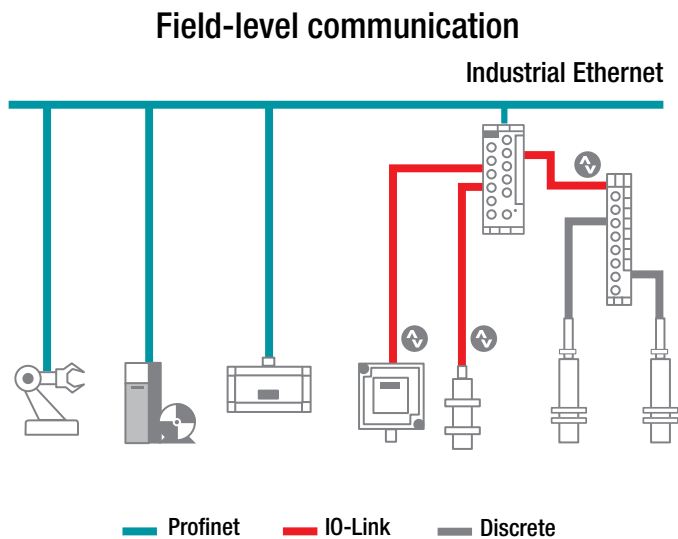

**Figure 2.** Field-level communication.

**Industrial Ethernet: the backbone of the smart factory**

In recent years, industrial Ethernet has demonstrated its value in highly automated factories, becoming the standard of choice in large field networks that include complex systems, PLCs and gateways to support intercommunication with external networks. Benefits such as high speeds, common interfaces and long connection distances have made Ethernet ubiquitous for data networks. In addition,

industrial Ethernet uses a modified media access control (MAC) layer to provide deterministic data delivery with low latency and support for time-triggered events. Support for ring and star topologies, as well as traditional in-line connections, ensure safety and reliability in the event of a disconnected cable.

Industrial Ethernet is not a unique single specification but a large group of differing protocol implementations driven by various industrial equipment manufacturers for implementation in field-level applications. Popular protocols include EtherCAT, Profinet, Ethernet/IP, Sercos III and CC-Link IE Field, among others. The white paper [“An inside look at industrial Ethernet communication protocols”](#) compares these protocols and discusses older, non-Ethernet serial field bus protocols such as Controller Area Network (CAN), Modbus and Profibus.

Two of the most widely used protocols, Profinet and EtherCAT, illustrate how the types of industrial Ethernet differ with each other and with IO-Link. Both are specified at 100-Mbps transmission speeds and over distances up to 100 m. Profinet requires a power supply that’s independent of the data cable power, while EtherCAT offers a version (EtherCAT P) that includes power and data in the same cable. Profinet supports full duplex traffic and is capable of sending packets to each node on the network. The protocol also offers three classes that allow users to match the level of performance required to the network. By contrast, EtherCAT sends a shared frame in one direction on the network in which all slaves place their data – a scheme that supports extremely fast forwarding times.

Both Profinet and EtherCAT have faster cycle times than IO-Link, with much less tolerance. Both base timing on network synchronization rather than from the start of communication, as with IO-Link. Additional protocols provide functional safety for connections. Industrial Ethernet protocols in general offer a number of services in order to simplify integration within an automation environment.

Although most sensors do not need the robust set of features offered by an industrial Ethernet connection, an important exception is visual sensing. The massive data created by a video camera is itself a sufficient reason for a higher data-rate connection than what IO-Link can offer. Visual and sometimes other types of sensing may provide essential inputs for real-time process control, thus requiring the deterministic delivery of industrial Ethernet.

For example, ToF applications track and anticipate the three-dimensional movement of an object. A typical response would be a robot arm that moves to intercept the object. IO-Link may provide sufficient speed and resolution for limited sensing of presence in these applications, but industrial Ethernet offers sufficient bandwidth and low-enough latency to determine some characteristics of the object and its surrounding space. Even higher levels of identification may be possible using camera feeds via Gigabit Ethernet, but the industrial Ethernet protocols discussed here have not yet been specified at these speeds. You can see a section example for ToF in **Figure 3**.

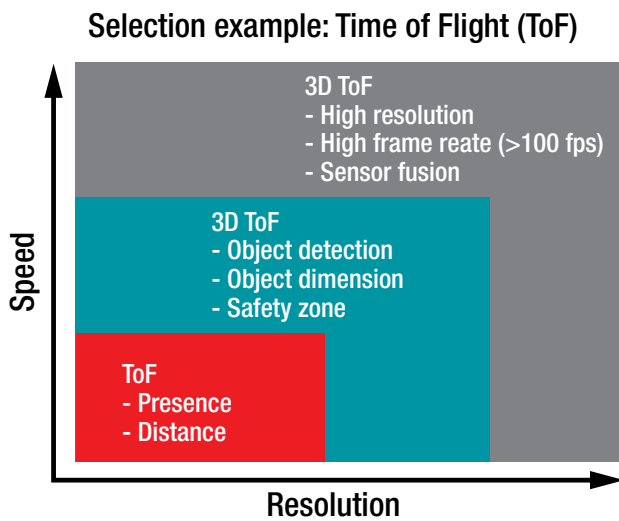

Figure 3. Selection example: ToF.

### TI technology for smart factory communications

Many possibilities exist among the competing industrial Ethernet protocols to serve cameras, motors, robots, PLCs and other complex systems; even simple sensors and actuators need to operate effectively within a larger industrial Ethernet environment. With so many options for communication among automated equipment, industrial system designers need solutions that are flexible but easy to use. TI technology addresses these requirements with integrated solutions for industrial communications based on a range of standards, including IO-Link and the most popular industrial Ethernet protocols.

TI's [TIOL111x](#) transceiver family provides complete IO-Link functionality plus electrostatic discharge, electrical fast transient and surge protection for sensors and actuators in automated systems. An EVM allows you to review the devices in operation, and reference designs help speed development of transmitters, proximity switches, solenoid drivers, ultrasound and other applications.

Application designers who require greater bandwidth and deterministic timing must decide how many industrial Ethernet protocols to support in order to make their systems compatible with multiple field bus environments. Traditionally, adding protocols requires creating additional interfaces or interchangeable modules that plug into the motherboard. Either decision involves additional hardware design, a larger bill of materials, and a longer cycle of testing and certification.

Instead of adding hardware, the TI [Sitara™ family](#) of Arm® processors offers an integrated programmable real-time unit and industrial communication subsystem (PRU-ICSS) that supports multiprotocol industrial Ethernet. **Figure 4** (next page) shows an example of a Sitara processor-based system communicating directly with IO-Link masters.

The PRU loads industrial protocol firmware at device run time, with options for EtherCAT, Profinet, Sercos III, Ethernet/IP and Ethernet PowerLink. The PRU-ICSS handles real-time critical tasks that you would otherwise build into an application-specific integrated circuit (ASIC) or field-programmable gate array (FPGA), thus offering an upgradable software-based solution if you need to add new features or protocols. Based on the scalable Arm core (Cortex®-A8, A9 or A15, depending on the processor), Sitara processors enable a single-chip solution for factory automation using multiple industrial Ethernet protocols.

TI offers a wide line of interfaces (as show in **Table 1 (next page)**) for industrial Ethernet and other standards such as CAN, both as stand-alone solutions and as technology modules available in other integrated solutions. Many TI network products feature reinforced isolation for the protection of circuitry and humans, while other devices provide reinforced isolation to add to designs. In-depth development support includes software, tools, EVMs and reference designs for a variety of applications in automated industrial equipment.

## IO-Link master with Sitara™ AM437x processor

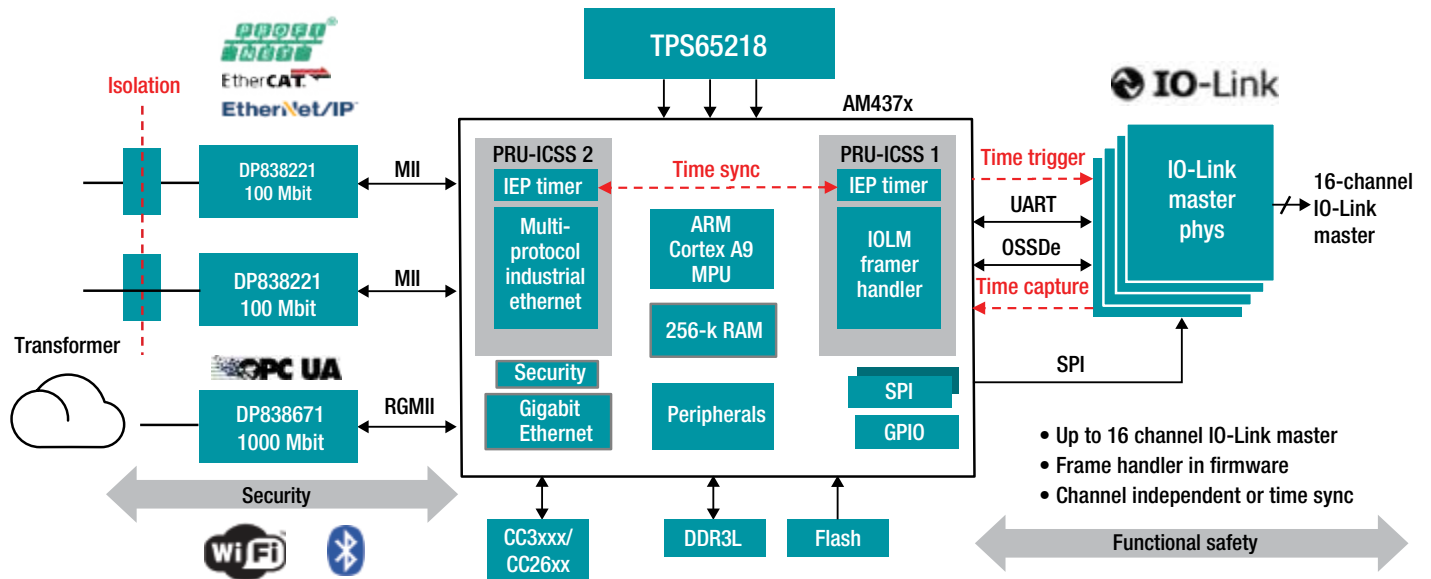

**Figure 4.** A Sitara™ processor-based system that communicates directly with IO-Link masters.

Feature	IO-Link	Profinet	EtherCAT	Comment
Physical layer	≤230 kbit, half duplex, 20 meter, power in same cable	100 Mbit, full duplex, 100 meter, separate power	100 Mbit, shared packet, 100 meter, power in same cable defined	Only Profinet supports concurrent receive and transmit of packets
Topology	Point to point	Line, ring, star	Line, ring, star	Ethernet allows for large scale networks
Min. cycle time	400 μs + 10%	250 μs (31.25 μs with DFP)	31.25 μs	IO-Link allows additional tolerance of +10%
Time synchronization	Based on communication start	PTCP <±1 μs, IRT test <250 ns	Distributed clocks ±100 ns	IO-Link has no application time
Security	Not available	Limitations of no Profinet traffic	Not available	All need additional security protocol for IT connection
Functional safety	Only sign of live on redundant channel	Profisafe	Funcational Safety over EtherCAT	Ethernet transmission is seen as black channel
Profiles and services	Smart sensor, fieldbus integration, firmware update, OPC UA	Profidrive, CiR, system redundancy, diagnostics	SoE, CoE, EoE, FoE, AoE, EAP	All support integration into automation network, no drive profile on IO-Link

**Table 1.** IO-Link versus industrial Ethernet for manufacturing field communications.

### Technology for the future of smart factories

The growth of smart factories depends on versatile networking that matches the requirements of individual equipment units with the overall communication needs of the factory. Industrial Ethernet protocols provide high bandwidth and fast, guaranteed timing for field bus connections to PLCs, cameras, robots and other complex automated

systems. IO-Link offers a straightforward alternative for point-to-point connection between a field bus master and a sensor or actuator, aiding in configuration and maintenance. TI offers a broad portfolio of solutions and flexible technology that help designers make use of these complementary standards as they create innovations in automation for the fourth industrial revolution.

## 6.2 Enabling robots to achieve new levels of factory automation

For more than half a century, robots have played an ever-increasing role in manufacturing, successfully transforming industries ranging from automobiles to electronics to consumer goods. Robots bring productivity, cost-efficiency and often greater safety to repetitive task performance.

Robots continue to evolve, offering greater functionality, flexibility, range of motion, speed and precision. Besides functioning in protected spaces on assembly lines, robots increasingly operate side by side and interact with human beings, and in some cases move materials from place to place. For robots to operate in these ever-more-complex ways, they must be able to process a great deal of sensing data about the environment, communicate with each other and with centralized control units, and perform control functions that adapt to environmental changes and keep them from harming humans.

By providing innovative electronic solutions for industrial automation, TI offers a full range of IC products that enable advanced robot system development. TI provides both individual products and complete solutions for control, communications, power and safety, from the highest control layer in a factory down to actuators and sensors. TI systems expertise is based on many years of engagement with leading manufacturers in many industries, and the company's in-depth support helps simplify the design of robotic systems and reduce development time.

### Types of robotic applications in industrial automation

Despite the widespread attention given to human- and animal-like robots, drones and even robot vacuums, robots used in industrial settings remain the mainstay of the robotics market. Many of the concerns that robot developers face when designing products for industrial use also apply to other areas of robotics, and the technology created to handle factory requirements often enables new robot applications outside of manufacturing.

While all robots used in industrial automation are technically industrial robots, for the purposes of this discussion the focus will be on three groups of robot applications: industrial robots as shown in **Figure 1**, logistics robots and collaborative robots. Industrial robots are units fixed in

place to handle tasks such as welding, painting, picking and placing, assembling, and lifting objects to set them on pallets or in containers. Control signals come from a robot controller, which is a control unit in a cabinet usually located at the base of or next to the robot.

Industrial robots are designed to perform tasks quickly, accurately and without direct interaction with humans. Thus, they have no sensors to perceive the presence of people, and are not designed to accommodate people within their operational space. When human interaction is necessary, the robot will usually be deactivated. For human safety and noninterference with operation, industrial robots are usually located inside fences, transparent walls, light-activated barriers, arrays of floor mats that cut off power when stepped on or other protective barriers.



**Figure 1.** Robot applications in industrial automation and service.

Logistics robots are mobile units that operate in environments where there may be people present, such as warehouses. Logistics robots might fetch goods and bring them to a packing station, or transport goods from one building of a company site to another; one recent development has robots delivering takeout, although they are currently accompanied by a human handler. These robots typically move within a particular environment and need a number of sensors for localization and mapping and to prevent collisions, especially with humans. Ultrasonic, infrared and LIDAR sensing are all possible technologies. Because of this robot's mobility, the control unit is located inside, often with wireless communication to a central remote control.



Collaborative robots have the most complex interactions with humans, often working directly with a person on the same object at the same time. A collaborative robot might hold an object while a human worker visually inspects it or performs fine-tuning tasks. The robot might then set the object down in an area where another robot can pick it up, possibly to move it to a new location for collaboration with a different worker.

Collaborative robot makers must implement a high level of environmental sensing and redundancy into robot systems to quickly detect and prevent possible collisions. Integrated sensors connected to a control unit will sense the collision between a robot arm and a human or other object; the control unit will turn the robot off immediately. If any sensor or its electronic circuit fails, the robot also turns off. Collaborative robots are typically fixed in place with a control unit in a cabinet, but can also be mounted onto a vehicle.

### Technology requirements for industrial robotics

Manufacturers investing in robots are seeking greater productivity coupled with a good return on investment in a reasonable time frame. Achieving these goals depends on how precise a robot can be during difficult tasks, its performance speed for highly repetitive tasks, its ability to maintain safety during dangerous tasks, or some combination of these capabilities.

Robots with flexible application capabilities such as the one shown in **Figure 2**, often using cameras to see objects, can save manufacturers from having to invest in more specialized machines, while enabling more complete, shorter and efficient production runs and new uses on the factory floor. In addition, many factories today are adding more layers of communication and control to production lines, bringing together more data for better process control and equipment maintenance while also making processes more responsive to changing product demands. Robots and other equipment that communicate among themselves and with higher-level control are essential to fully integrated factories.

Robot developers rely on advanced IC solutions to meet these requirements. IC products that enable advances in industrial robots must provide precise sensing, high-speed sensor signal conversion, fast computation/signal processing for real-time response and high-speed communications. ICs also enable high efficiency and small-form-factor power supplies in conjunction with advanced semiconductors like GaN FETs.

All of these factors are especially important as the number of sensors and environmental stimuli increases. Robot developers depend on solutions that minimize the headaches of circuit design and certification, speeding the development of products that they can deliver to industrial customers quickly.

Advanced ICs must offer features that include:

- A high-efficiency, high-voltage power supply with circuit protection and low-noise emissions.
- Characterization for an extended temperature range.
- Support for industrial Ethernet and other widely used industrial communication standards.
- Ease of programming for greater flexibility.
- Fast, precise analog-to-digital and digital-to-analog signal conversion.
- Reinforced isolation to meet industrial safety standards.
- Control redundancy for safety-critical applications when combined with other ICs.
- A small footprint when placing circuitry in tight spaces such as mobile logistic robots, or for motor control in robot arms (along with other equipment with tight spaces, such as sensors and motor housings).
- Low power consumption (critical for battery- or ambient-powered equipment such as logistics robots and sensors).
- Comprehensive support, including reference designs and EVMs to minimize design time and let designers focus on value-added technology.



**Figure 2.** An assembly line with robots interacting.



## TI's enabling technology for industrial robots

TI offers the full range of advanced technology needed to design flexible robots that operate within the environment of today's integrated manufacturing plants. From sensor input to actuator or motor output, from individual equipment units to factory-level control and beyond, TI solutions handle the entire signal chain, as well as the processing and power required for robotic applications. Products include features such as reinforced isolation, and are tested and qualified for use in harsh industrial environments. To close the circle, TI backs its IC products with in-depth support that simplifies design and speeds development.

Among the many solutions that TI offers for robots and other industrial equipment, these are especially notable:

- **Sitara™ processors.** The heart of any control unit is the processor, and TI's system-optimized Sitara processors are designed for flexible, fast design in robots and other industrial equipment. Based on ARM® Cortex®-A cores, Sitara processors provide flexible peripherals, connectivity and unified software support to cover a wide set of applications. A broad portfolio of single- and multicore devices provides a selection that offers the perfect balance of integration, connectivity and performance for every application. A fully scalable software platform enables a unified software experience for simplified development and code migration across Sitara processors and TI DSP families. Pin-compatible options within processor families make hardware upgrades seamless.

Sitara processors are designed to meet industrial requirements for long-term applications, with product life cycles typically in excess of 10 years. The devices provide programmable flexibility when implementing specialized data-handling operations, custom peripheral interfaces and fast real-time responses as short as 5 ns. The programmable real-time unit-industrial communication subsystem (PRU-ICSS), which exists as a hardware block inside the Sitara processor family, replaces field-programmable gate arrays (FPGAs) or application-specific ICs (ASICs) with a single-chip solution. Easy access to free software and design tools, plus a large base of open-source community support, reduce barriers to development.

- **Proximity sensing.** Collaborative robots require sophisticated sensing of nearby things and people in order to make them safe. TI's expertise in sensing technology includes solutions for proximity sensing in applications that detect the presence of a target object and, if required, measure its distance. Techniques that TI supports for proximity sensing include ultrasonic, magnetic, capacitive, inductive and ToF.
- **3D ToF/optical sensing.** TI products enable ToF-based sensing to go beyond proximity detection to next-generation machine vision. TI's 3D ToF chipsets provide maximum flexibility for you to customize designs for robot vision or other applications. Tools include an EVM and a highly configurable camera development kit; the latter provides a 3D location of each pixel for accurate depth maps that aid customization for a given application.
- **GaN power.** In addition to an extensive power-management portfolio of switching and linear regulators, switching controllers, power monitoring and other supporting power-management devices, TI offers [GaN modules, drivers and controllers](#) that provide outstanding power density for high-voltage power supplies in industrial systems.  
  
GaN technology greatly reduces switching losses and therefore enables faster switching speeds while reducing or eliminating heat sinks. Easy-to-use modules provide a complete solution with optimized layout and efficiency, along with minimum electromagnetic emission and noise for compliance with industrial standards. Complete support includes EVMs, development boards and a quick-start tool set to speed design. For accurate control of precision drives, TI's reference design library includes a [48-V 3-Phase Inverter with Shunt-Based In-Line Motor Phase Current Sensing Reference Design](#).
- **Industrial Ethernet.** TI's in-depth expertise in network communications means support for a wide range of standards. The protocol includes essential setup tasks, and open-source firmware enables product differentiation.

## Building better robots for the integrated factory

As manufacturing continues to become more highly integrated at all levels, robots will play an ever-increasing role in carrying out a wide variety of assembly tasks that increase production and make the workplace safer for humans. Traditional industrial robots, logistics robots and collaborative robots have their jobs to do, and robot developers need solutions that enable accurate, safe, cost-effective operation from all of them.

TI's IC products for signaling, processing, communications and power management help provide the solutions that robotics manufacturers need. TI backs its semiconductor and IC products with software tools, EVMs and reference designs, and other forms of support that help make the work of designing robots faster and more profitable. As robots are improving manufacturing, TI is helping developers improve robots.

### 6.3 Is your factory smarter than a fifth grader?

Looking at the future of factory automation, IO-Link is an enabling interface for Industry 4.0. You can use the IO-Link bidirectional, manufacturer-independent communication protocol to develop highly efficient and scalable “smart factories.”

TI's TIOL111 IO-Link transceiver and TIOS101 digital output switch will help enable the next generation of sensors and actuators in factories, while providing features that further optimize product offerings and simplify bill of materials.

You can take advantage of the pin compatibility between the TIOL111 and [TIOS101](#) devices to develop a complete portfolio of both IO-Link and standard input/output (SIO)-enabled sensors without using two separate PCBs for each offering. Each device supports the interfaces intended while also supporting a high level of integrated protection, including:

- 16-kV International Electrotechnical Commission (IEC) 61000-4-2 electrostatic discharge (ESD).
- 4-kV IEC 61000-4-4 electrical fast transient (EFT) Criterion A.
- 1.2-kV/500-Ω IEC 61000-4-5 (surge).
- ±65-V transient tolerance.
- Reverse polarity up to ±55 V.
- Overcurrent/overvoltage/over temperature.

This level of protection can simplify designs by eliminating or greatly reducing the size of external transient voltage suppression (TVS) diode components that originally provided protection, thus reducing the overall BOM and associated costs when compared to previous-generation or competing solutions.

The physical size of sensors continues to shrink. The smallest of these sensors is likely the cylindrical sensor, as shown in **Figure 1**.



**Figure 1.** An IO-Link cylindrical sensor.

The sensor at the top of Figure 1 is the finished product with a cylindrical enclosure. The middle wire is the sensor's internal PCB. This PCB measures 17.5 mm by 2.5 mm. In order to fit in these small form factors, an equally small device is required to implement either IO-Link or SIO output. Knowing these system requirements drove new package developments for the TIOL111 and TIOS101. The DMW package is one of the smallest, thermally enhanced IO-Link packages available today. Measuring 3.0 mm by 2.5 mm, the DMW package also supports a thermal pad for heat conduction and a flow-through pinout. The flow-through pinout (**Figure 2**) further aides in PCB layout and device placement by supporting the logic interface to the microcontroller on one X-axis and the 24-V IO-Link interface on the other.

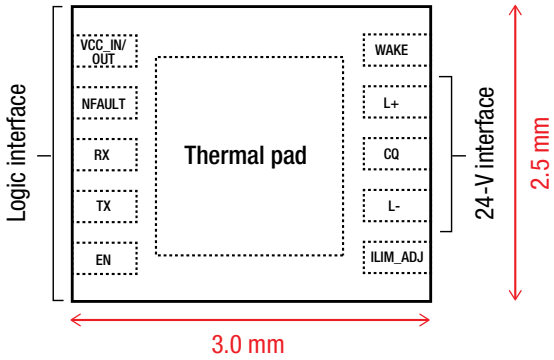

Figure 2. TIOL 111/TIOS101 flow-through package.

The TIOL111 and TIOS101 have a low residual voltage of just 1.75V – the size of sensors that use IO-Link and SIO are rugged, sealed and often very small. This small, enclosed form factor introduces numerous design challenges, with thermal performance one of the most challenging. By supporting an ultra-low residual voltage of 1.75 V at 250 mA, the TIOL111 and TIOS101 provide a superior base for power dissipation and related system thermal management. **Table 1** shows the driver current output and residual voltage for high side and low side.

	Driver current output	Residual voltage
High side	100 mA	1.1 V
	200 mA	1.5 V
	250 mA	1.75 V
Low side	100 mA	1.1 V
	200 mA	1.5 V
	250 mA	1.75 V

Table 1. Power dissipation = residual voltage × 10.

A configurable current limit is an additional protection feature that can protect the sensor and possibly prevent the network from shutting down. Through a 0-kΩ to 100-kΩ resistor, the TIOL111 and TIOS101 can support a 50-mA to 350-mA current limit. This limiter can notify the programmable logic controller (PLC) of an overcurrent condition and shut down the device’s output, with periodic monitoring of the overcurrent condition.

The configurable current-limit resistor is placed on the ILIM\_ADJ pin (see **Figure 3**).

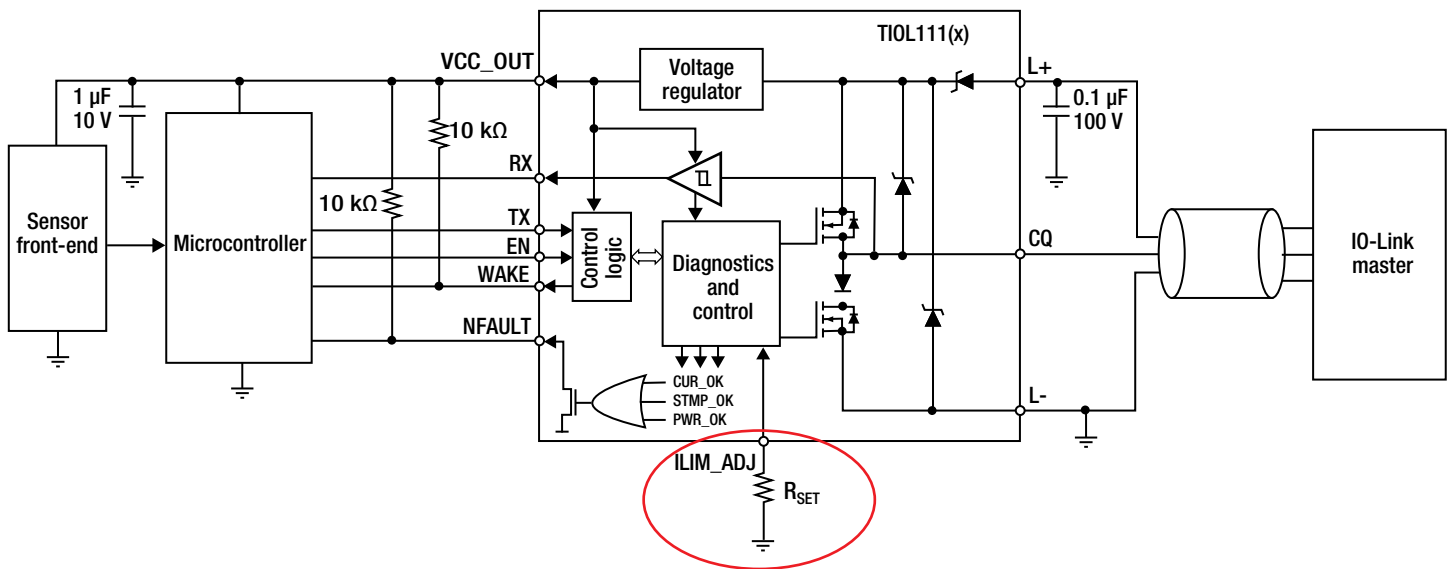
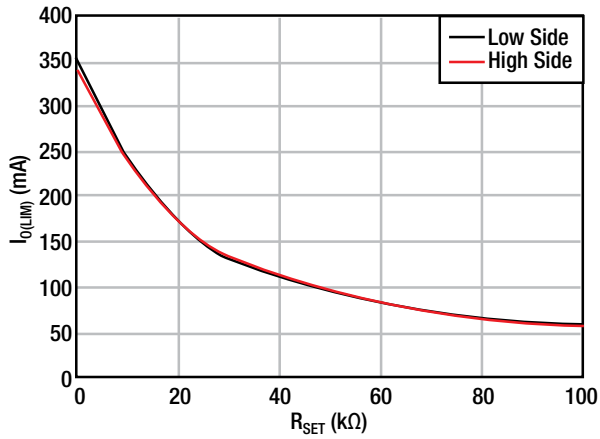

Figure 3. TIOL 111 application schematic.

As **Figure 4** indicates, using a 0-Ω resistor on the ILIM\_ADJ pin will default to the maximum current limit of 350 mA.

These and other features and benefits of the TIOL111 and TIOS101 can enable the smallest sensor form factors, while providing the flexibility to support multiple platforms and current configuration requirements.



**Figure 4.** Current limit vs.  $R_{SET}$ .

## 6.4 Industrial communications-related reference designs for robotic systems

<a href="#">EtherCAT Slave and Multi-Protocol Industrial Ethernet Reference Design</a>	<p>This design implements a cost-optimized high electromagnetic compatibility immunity EtherCAT slave (dual ports) with a Serial Peripheral Interface to the application processor.</p> <p>The hardware design is capable of supporting multiprotocol industrial Ethernet and field buses using the AMIC110 industrial communications processor.</p>
<a href="#">Redundant Dual-Channel Safe Torque Off (STO) Reference Design for AC Inverters and Servo Drives</a>	<p>This reference design implements safe torque off functionality in variable speed drives (per International Electrotechnical Commission 61800-5-2) by using dual-channel isolated STO signals to control the inverter that supplies power to the motor.</p>
<a href="#">Simple Open Real-Time Ethernet (SORTE) Master with PRU-ICSS Reference Design</a>	<p>The reference design implements a SORTe master with the programmable real-time unit (PRU) and industrial communication subsystem. SORTe enables applications to exchange process data between the master and devices in a 4-μs cycle time. The design contains open-source PRU firmware.</p>
<a href="#">EtherCAT P One Cable for Power and EtherCAT Reference Design</a>	<p>This reference design shows a physical implementation of the power couple in circuitry of an EtherCAT P power-sourcing device. The design is designed to meet all requirements from the official EtherCAT P implementation guide.</p>

[Find more reference designs for your robot system.](#)

Contributing authors: Thomas Leyrer, Miro Adzan, Anant Kamath, Tobias Puetz and Russell Crane.

## ***TI Worldwide Technical Support***

---

### **TI Support**

Thank you for your business. Find the answer to your support need or get in touch with our support center at

[www.ti.com/support](http://www.ti.com/support)

China: <http://www.ti.com.cn/guidedsupport/cn/docs/supporthome.tsp>

Japan: <http://www.tij.co.jp/guidedsupport/jp/docs/supporthome.tsp>

### **Technical support forums**

Search through millions of technical questions and answers at TI's E2E™ Community (engineer-to-engineer) at

[e2e.ti.com](http://e2e.ti.com)

China: <http://www.deyisupport.com/>

Japan: <http://e2e.ti.com/group/jp/>

### **TI Training**

From technology fundamentals to advanced implementation, we offer on-demand and live training to help bring your next-generation designs to life. Get started now at

[training.ti.com](http://training.ti.com)

China: <http://www.ti.com.cn/general/cn/docs/gencontent.tsp?contentId=71968>

Japan: <https://training.ti.com/jp>

**Important Notice:** The products and services of Texas Instruments Incorporated and its subsidiaries described herein are sold subject to TI's standard terms and conditions of sale. Customers are advised to obtain the most current and complete information about TI products and services before placing orders. TI assumes no liability for applications assistance, customer's applications or product designs, software performance, or infringement of patents. The publication of information regarding any other company's products or services does not constitute TI's approval, warranty or endorsement thereof.

The platform bar, C2000, LightCrafter, E2E, InstaSPIN, Hercules and Sitara are trademarks and DLP is a registered trademark of Texas Instruments. All other trademarks are the property of their respective owners.



## IMPORTANT NOTICE AND DISCLAIMER

TI PROVIDES TECHNICAL AND RELIABILITY DATA (INCLUDING DATASHEETS), DESIGN RESOURCES (INCLUDING REFERENCE DESIGNS), APPLICATION OR OTHER DESIGN ADVICE, WEB TOOLS, SAFETY INFORMATION, AND OTHER RESOURCES "AS IS" AND WITH ALL FAULTS, AND DISCLAIMS ALL WARRANTIES, EXPRESS AND IMPLIED, INCLUDING WITHOUT LIMITATION ANY IMPLIED WARRANTIES OF MERCHANTABILITY, FITNESS FOR A PARTICULAR PURPOSE OR NON-INFRINGEMENT OF THIRD PARTY INTELLECTUAL PROPERTY RIGHTS.

These resources are intended for skilled developers designing with TI products. You are solely responsible for (1) selecting the appropriate TI products for your application, (2) designing, validating and testing your application, and (3) ensuring your application meets applicable standards, and any other safety, security, or other requirements. These resources are subject to change without notice. TI grants you permission to use these resources only for development of an application that uses the TI products described in the resource. Other reproduction and display of these resources is prohibited. No license is granted to any other TI intellectual property right or to any third party intellectual property right. TI disclaims responsibility for, and you will fully indemnify TI and its representatives against, any claims, damages, costs, losses, and liabilities arising out of your use of these resources.

TI's products are provided subject to TI's Terms of Sale ([www.ti.com/legal/termsofsale.html](http://www.ti.com/legal/termsofsale.html)) or other applicable terms available either on [ti.com](http://ti.com) or provided in conjunction with such TI products. TI's provision of these resources does not expand or otherwise alter TI's applicable warranties or warranty disclaimers for TI products.

Mailing Address: Texas Instruments, Post Office Box 655303, Dallas, Texas 75265  
Copyright © 2020, Texas Instruments Incorporated