

Operation Manual

AOYUE Repairing/Hot Air Soldering Station

902703A+



Illustration similar, may vary depending on model

Read and follow the operating instructions and safety information before using for the first time.

Technical changes reserved!

Due to further developments, illustrations, functioning steps, and technical data can differ insignificantly.

Updating the documentation

If you have suggestions for improvement or have found any irregularities, please contact us.

The information contained in this document may alter at any time without previous notice. It is prohibited to copy or spread any parts of this document in any way without prior written allowance. All rights reserved.

The WilTec Wildanger Technik GmbH cannot be held accountable for any possible mistakes in this operating manual, nor in the diagrams and figures shown.

Even though, the WilTec Wildanger Technik GmbH has undergone biggest possible efforts to ensure that the operating manual is complete, faultless, and up to date, mistakes cannot be entirely avoided.

If you should find a mistake or wish to make a suggestion for improvement, we look forward to hearing from you.

Send an e-mail to:

service@wiltec.info

or use our contact form:

<https://www.wiltec.de/contacts/>

The most recent version of this manual in various languages can be found in our online shop via:

<https://www.wiltec.de/docsearch>

Our postal address is:

WilTec Wildanger Technik GmbH
Königsbenden 12
52249 Eschweiler
Germany

Do you wish to pick goods up? Our pick-up address is:

WilTec Wildanger Technik GmbH
Königsbenden 28
52249 Eschweiler
Germany

To shorten the waiting time and allow for a rapid on-site transaction, we ask you to call us previously or placing your order via the webshop.

E-mail: service@wiltec.info

Tel: +49 2403 55592-0

Fax: +49 2403 55592-15

To return orders for exchange, repair, or other purposes, please use the following address. Attention! To allow for a smooth execution of your complaint or return, it is important to contact our customer service team before returning the goods.

Returns Department
WilTec Wildanger Technik GmbH
Königsbenden 28
52249 Eschweiler

E-mail: service@wiltec.info

Tel: +49 2403 55592-0

Fax: +49 2403 55592-15

Introduction

Thank you for purchasing this quality product. **To minimise the risk of injury we urge that our clients take some basic safety precautions when using this device. Please read the operation instructions carefully and make sure you have understood its content.**

Keep these operation instructions safe.

General safety instructions

CAUTION:

The use of the device is only permitted with a residual current circuit breaker with a triggering rated current of up to 30 mA (according to VDE 0100 parts 702 and 738).

This device is not intended to be used by persons (including children) with limited physical, sensory, or mental capabilities or lack of experience and/or knowledge, unless they are supervised by a person responsible for their safety receive instructions or have been instructed on how to use the device correctly. Children should be supervised to ensure that they do not play with the device.

During operation, the temperature of the soldering iron, hot air iron and nozzle is between 200 °C and 480 °C. This could cause injury or damage to equipment in the work area if the soldering station is not handled carefully.

When working with the device, observe the following principles:

- After opening the package, check whether each individual part of the device is in good condition and whether there is any visible transport damage. If there is obvious damage, do **not** use the device and **immediately** contact your dealer!
- Switch off the device and pull the power plug if you want to move the device.
- Avoid subjecting parts of the device to increased mechanical stress (impact, etc.).

CAUTION:

- Perform a visual inspection of the device before each use. Do not use the device if safety devices are damaged or worn. Never override safety devices.
- Only use the device according to the intended use specified in these operating instructions.
- You are responsible for the safety in the work area.
- If the cable or the plug is damaged due to external influences, the cable must not be repaired, but replaced with a new one.
- The voltage of 230 V AC indicated on the nameplate of the device must correspond to the existing mains voltage.
- Never lift, transport, or fasten the device by the power cord.
- Make sure that the electrical plug connections are protected from flooding and moisture.
- Before working on the device, pull out the mains plug.
- Avoid exposing the device to direct water jets.
- The operator is responsible for compliance with local safety and installation regulations. Consult a qualified electrician if necessary.
- If the device fails, repairs may only be carried out by a qualified electrician.

WARNING:

Read all safety instructions and warnings. Failure to follow the safety instructions could result in electric shock, fire, and/or serious injury.

Keep all safety notices and instructions for future use.

Electrical connection

The electrical connection is made to an earthed socket with 230 V ~ 50 Hz; protection at least 10 A.

Commissioning

- Set up the device on a level and firm place, whose temperature does not exceed 40 °C. The device must be level at the location so that it can work properly.
- Establish the electrical connection.

Safety instructions



For your own safety, please follow the advice below, otherwise damage and/or injury could result:

- The temperatures of parts of the station can be up to 480 °C during operation, therefore:
 - Do not use the station near flammable gases, paper, or other flammable materials.
 - Avoid touching hot parts of the station, otherwise you could be seriously burned.
 - Do not touch the metallic parts near the soldering tips.
- Temperature protection:
 - The device is equipped with an automatic temperature protection which switches off the device if one of the temperatures is too high.
 - The device switches on again when the status has returned to normal.
- Handle the device carefully:
 - Never drop it and do not subject it to knocks.
 - Contains sensitive components that could be destroyed if improperly handled.
- Disconnect the device from the power supply if you do not need it for a long time, if there is a power failure or before you open it.
- Soldering may produce harmful fumes. Only solder in a well-ventilated work area to avoid harmful concentrations.
- Do not make any structural changes to the device.

Product description

- The Aoyue repairing/hot air soldering station INT2703A+ combines the functions of a hot air gun, a soldering iron, a solder fume extractor, and a de-soldering gun in one device.
- The dual output system of the INT2703A+ enables the de-soldering gun and soldering iron to be operated at the same time.
- The nozzle was equipped with a special air distribution technology (air spreader) allowing an even better reflow soldering, as the air and heat distribution has been optimised.
- The system has various safety functions such as the self-cooling function of the heat gun. This function protects the device and its components from overheating in the following situations, for example:
 - if the heat gun has not been used on the holder for a long period of time;
 - when the temperature gets too high.
- The temperature and the air flow can be conveniently set separately using 4 buttons each. The heat gun, the soldering iron and the de-soldering gun have an adjustable automatic sleep function.
- Five different reworking profiles can be saved, so that constant work can be guaranteed automatically.
- The unique and innovative design with digital control and display offers precision and safety and meets all the necessary requirements for problem-free reworking.

Technical specifications

Input voltage (V)	230
Size (mm)	188 (W) × 126 (H) × 250 (D)
Weight (kg)	5.6
<i>Soldering iron</i>	
Power (W)	70
Temperature range (°C)	200–480
Heating element	Ceramic heating element
Output voltage (V)	24
Resistance to earth (Ω)	< 2
Potential difference to earth (mV)	< 2
<i>De-soldering gun</i>	
Temperature range (°C)	200–480
Heating element	Ceramic heating element
Output voltage (V)	24
<i>Hot air iron</i>	
Power (W)	500
Temperature range (°C)	100–480
Heating element	Metal
Motor	Special diaphragm pump
Max. flow rate (l/min)	23

- Monitored by CPU
- 3-in-1 repairing station: hot air iron, soldering iron and de-soldering gun
- Advanced air distribution technology (air spreader)
- Antistatic design (ESD-safe)
- User-friendly touchpad for easy and effective configuration
- Hot air and soldering temperature controlled by microprocessor and sensors
- Soldering iron combined with soldering fume extraction
- Powerful de-soldering iron with catching spring element
- Heating element continuously cooled with cold air after use to increase service life
- Automatic standby for soldering iron and de-soldering gun
- Compatible with many different hot air nozzles
- Compatible with many different soldering tips
- Five programmable profiles
- Heating element and soldering tip combined in one component, thus enabling easy replacement
- User-configurable sleep (“auto sleep”)

Preparations

Main station

- **Transport lock:** As soon as you have taken the station out of the packaging, the security screw must be removed. It is in the middle on the base of the main unit.

- The screw is used to secure the pump during transport. It is imperative to remove this screw before use.

Soldering iron

- Attach the solder wire to the soldering iron holder as shown in the picture.

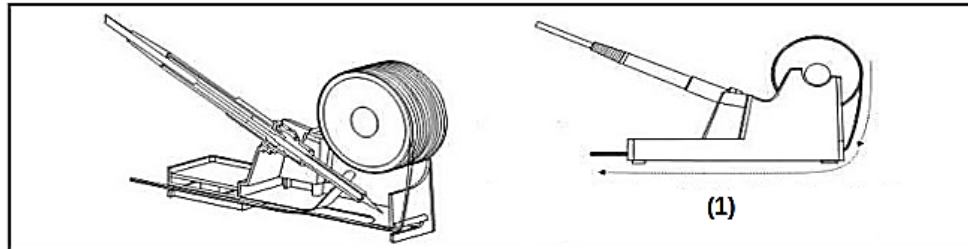

(1) = direction of solder wire

- Insert the soldering iron into the 6-pin socket provided on the front of the device (9 in the illustration of the operating elements).
- Place the soldering iron on its holder as shown in the illustration.

Soldering fume extraction

1. Connect the soldering fume extractor hose to the socket provided for it (7).
2. Make sure that the hose is not knotted or kinked.

Hot air iron

For packaging reasons, the hot air iron holder is attached to the station the wrong way round (upside down). Loosen the two screws, turn the holder over and screw it back on.

De-soldering gun

1. Connect the cable to the 6-pin socket on the device (9).
2. Connect the vacuum hose to the socket provided (7).
3. Place the de-soldering gun in its holder to prepare for use.

Operation elements

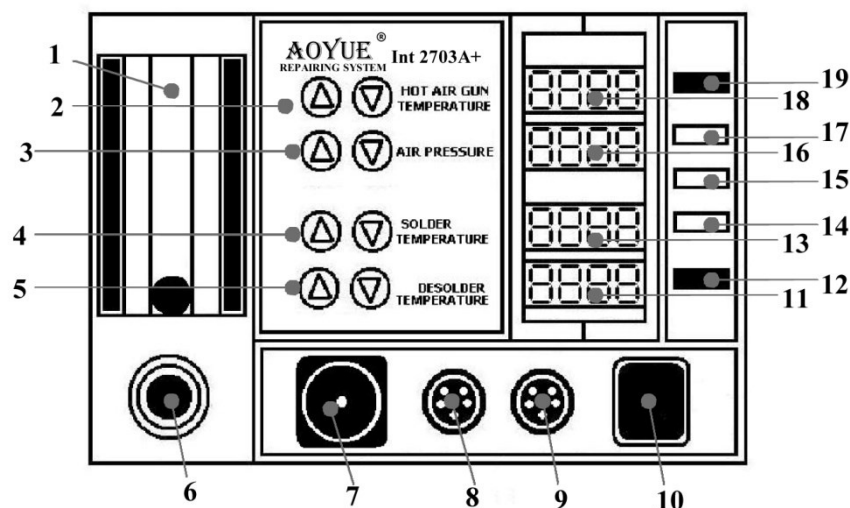



No	Name	No	Name
1	Air flow display	11	De-soldering gun temperature display
2	Hot air iron temperature adjustment	12	De-soldering gun on/off switch
3	Hot air iron air flow adjustment	13	Soldering iron temperature display
4	Soldering iron temperature adjustment	14	Soldering iron on/off switch
5	De-soldering gun temperature adjustment	15	Fume extraction on/off switch
6	Hot air iron outlet	16	Hot air iron air flow/automatic display
7	Fume extraction connection and vacuum connection for de-soldering gun	17	Hot air iron functional switch
8	Soldering iron connection	18	Hot air iron temperature/automatic display
9	De-soldering gun connection	19	Hot air iron on/off switch
10	Main switch		

Commissioning details

Important:

- Make sure that the device is on a level surface and that all heat-generating components are in their holders.
- All switches must be in the off position.
- All connections must be properly made.

Start-up

1. Connect the device to the power supply using the power cord supplied.
2. Make sure that all function switches are set to Off before you operate the main switch **(10)** of the station.
3. The product name is briefly displayed in ticker and then "OFF" on the display panels. This display remains until the user activates a function.

Hot air iron

1. Follow the steps listed under "Start-up."
2. Activate the on/off switch of the hot air iron **(19)**.
3. The station immediately generates an air flow at a speed of 50 $\frac{1}{min}$ and heats up to a temperature of 100 °C (basic settings). These values should be shown on display fields **18** and **16**. The ball in the airflow display should be approximately in the middle of the display.
4. Set the desired air flow using the air flow regulator **(3)**.
5. You can set the temperature of the hot air iron with the help of the corresponding regulator **(2)**.

Caution: It is strongly recommended that you first regulate the air flow and then set the desired temperature. This prevents the heating element from overheating and thus ensures a longer service life for the element.

6. You can start working about a minute after you have set the desired temperature. To ensure that the station has really reached the desired temperature, please check the display on display field **18**.
7. When you have finished your work, please place the hot air iron in its holder and DO NOT switch the station off.
8. First switch off the hot air function to activate the self-cooling. The system now blows air at room temperature onto the heating element to cool it down to about 90 °C. During this time, the display changes to "Cool." When the temperature has dropped to 90 °C, the display shows "OFF."
9. Switch off the system.

10. Pull out the power plug.

- When selecting the nozzle, adapt it to the corresponding IC component.
- Loosen the fastening screw of the hot air nozzle.
- Attach the nozzle to the hot air tube (see Fig. 2).
- Tighten the fastening screw appropriately, but not too tight, as glass is incorporated into the handle.
- Place the hot air iron in its holder.

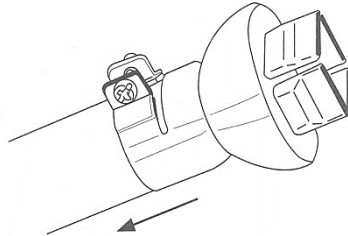

Automatic reworking

The system has a function enabling you to automate reworking. To make the desired settings, follow these steps:

1. Make sure that the hot air function is switched off.
2. Thanks to the function switch on the hot air iron, you can switch between the individual levels of the profile. The individual levels are marked with the following symbols: A, b, c, d, and E for levels 1–5. The display field **18** shows the selected temperature and the field **16** shows the period in which this temperature is to be reached.
3. Press the function switch on the hot air iron to change the settings. The fields now show “### A” and “### t.” The value with the ending “A” is the temperature value, the value with the ending “t” is the time in which the selected temperature should be reached.
4. Use the temperature setting button of the hot air function to set the desired temperature. You can change the time using the air flow control button. To switch between the individual levels, simply press the hot air piston function key repeatedly.
5. To save the new settings, press and hold the hot air iron function key until the display shows “SAVE.” Press the up button (arrow up) of the hot air function to confirm saving.

To be able to work with the set values, please follow the next steps:

1. Make sure that the hot air function is switched off.
2. Hold down the hot air iron function button (**17**) until the display shows “run.”
3. Press the up button (arrow up) of the hot air function to start the automatic rework.

Once started, the station slowly begins to increase the temperature of the hot air unit. After the temperature of segment A has been reached, it is counted down. When “0” is reached after the pre-set time, the next segment is started until the entire program has run through. After the end of the program, the cooling starts automatically.

Note:

- The temperature of the hot air unit can be set from 100 °C to 480 °C.
- The air flow rate is adjustable from 15 to 100 $\frac{1}{\text{min}}$.
- The hot air unit is equipped with a temperature limiter which only allows a temperature increase of 3 $\frac{1}{\text{s}}$. This corresponds to the industry standard and prevents sensitive components from being damaged if the temperature rises too quickly.

Soldering iron

1. Insert the soldering iron into the 6-pin socket (**9**) provided on the front of the device.

2. Follow the instructions given under "Commissioning."
3. If you want to use the fume extraction function, insert the hose of the fume extraction into the socket provided for it **(7)**.
4. Activate the on/off switch of the soldering iron **(14)**. The soldering iron now heats up by itself to 350 °C (basic setting).
5. Set the required temperature using the temperature controller **(4)**.
6. If you use the fume extraction system, press the on/off switch **(15)**.
7. You can start working when the desired temperature is reached.
8. When you have completed the work, switch off the fume extraction system.
9. Switch off the soldering iron function.
10. Let the soldering iron cool down before packing it up.

De-soldering gun

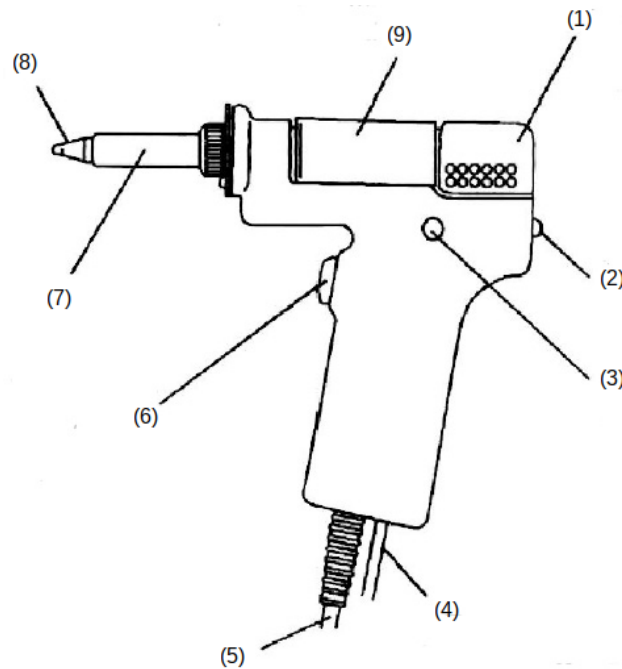

No	Name	Function	No	Name	Function
1	Filter holder	Securing the filter	6	Trigger	Starting the extraction (press to do so); do not press if the nozzle is not fully warmed up.
2	Eject knob	Unlocking to remove the filter	7	Heating element	Heating; has to be cleaned regularly.
3	Pressure display	Indicating when the nozzle or heating element needs cleaning, or the filter needs replacing.	8	Hot nozzle	Melting solder, input for melted solder
4	Vacuum hose	Connecting to the station	9	Filter	Collecting solder and flux in a ceramic paper filter
5	Electric cable	Connecting to the station			



1. Plug the connection cable of the de-soldering gun into the socket **(8)** provided on the front of the device.
2. Follow the instructions under “Commissioning.”
3. Connect the vacuum hose to the socket **(7)** provided for it.
4. Activate the on/off switch **(9)** of the soldering iron. The de-soldering gun now heats up to 350 °C (basic setting).
5. Set the temperature of the de-soldering gun to the desired value using the controller **(4)**.
6. Let the de-soldering gun heat up. The tip takes about 5–6 min to heat up while the inner solder drain takes about 5–9 min longer to reach operating temperature. If the operating temperature has **not** been reached, the solder drain can become clogged. Then let the de-soldering gun heat up a little longer.
7. Make sure that the solder has melted before “sucking it up.” Not completely melted solder clogs the solder drain.
8. Hold down the button for 1–2 s longer to activate the pump to ensure that even larger clumps get into the filter and do not clog the solder drain.
9. Clean the filters and springs regularly to achieve uniform suction.
10. When having finished work, press the soldering iron on/off switch.

Caution:

- **Follow the instructions and notes to ensure that your device functions properly.**
- **Industry recommended values:**
 - **315–320 °C for ordinary solder;**
 - **340–370 °C for lead-free solder.**
- **The operating temperature of the soldering iron and the de-soldering gun is between 200 °C and 480 °C.**
- **Due to the different heating elements and the size differences between the soldering tip and the de-soldering gun, the soldering iron heats up faster than the de-soldering gun. This is normal and does not indicate a malfunction of the station.**
- **The temperature display shows fluctuations when you use the de-soldering gun. They are created by the draught when the pistol is operated.**

Hot air safety function

The hot air function uses a safety setting that prevents the temperature from rising faster than 3 °/s. This corresponds to the industry standard and prevents sensitive components from being damaged if the temperature rises too quickly. This function is activated in the standard settings and can be deactivated if necessary. Please follow the next steps to switch off this safety function:

1. Switch off the station and make sure that all function switches are set to off.
2. Hold down the following two buttons: hot air iron function switch **(17)** and de-soldering iron temperature setting **(5)**.
3. Switch on the station at the main switch while you hold down the two buttons.
4. Release the switch when “SAFE OFF” appears in the display (the display appears in the temperature and airflow display field of the hot air function).
5. The field above the word “SAFE” shows whether the function is switched on or switched off. The system now switches to standby.
6. To turn the feature on or off, just follow steps 1–5.
7. The setting remains saved until changed again.

Hot air iron standby

The device has an automatic standby function which ensures that the hot air iron is switched to standby when in the holder and not in use. In this case, the display on the temperature display changes from “C” to “d.” After cooling down, the system starts to cool the hot-air piston by blowing in air at room temperature. The display field shows the word “cool” as it cools down. As soon as 90 °C are reached, the air

supply is stopped and the display in the field changes to “----.” The hot air iron is now completely in standby. To be able to use the station again, simply lift the hot air iron out of its holder.

Changing the hot air iron standby countdown

The device is set at the factory so that standby switches on after 15 min. You can change this with the following steps:

1. While the hot air iron is in standby (display fields **16** and **18** show “OFF”), press and hold the button to increase the air flow (**3**).
2. Wait until “t015” appears in display **18**.
3. Release the button as soon as the display appears.
4. Change the value using the hot air iron temperature control.
5. Confirm the change by pressing the airflow decrease button.
6. The station displays “OFF” again, the settings are saved.

You can set a countdown between 1 and 60 min. The hot air iron and soldering iron settings are saved and should work as set until changed. If you select “0,” the countdown to standby will be disabled.

Activating the soldering iron standby

The station can save electricity and thereby extend the service life of the heating element. Standby can be switched on for both the soldering iron and the de-soldering iron to save electricity. In standby the display shows “----.” To reactivate the soldering or de-soldering iron, simply press the function keys or the temperature controls. The standby of the soldering iron is switched off at the factory. To switch this function on, follow the next steps:

1. Switch off the soldering function on the station (**14**). Make sure that the de-soldering function is deactivated (**12**).
2. Hold down the down button of the de-soldering function (**5**).
3. Release the button when the temperature display field of the soldering function (**14**) shows “oot.” You can now set the soldering iron standby function.
4. Use the soldering iron temperature adjustment buttons to set the desired time. You can set a time between 1 min and 60 min. If you set the value “0,” the standby function is switched off.
5. Confirm the settings by pressing the down button for the de-soldering function (**5**).

Activating the de-soldering iron standby function

The standby function of the de-soldering iron is switched off at the factory. To switch the function on, please follow the next steps:

1. Switch off the soldering function on the station (**14**). Make sure that the de-soldering function is deactivated (**12**).
2. Hold down the down button of the soldering function (**4**).
3. Release the button when the temperature display field of the soldering function (**14**) shows “oot.” You can now set the standby function of the de-soldering iron.
4. Use the temperature adjustment buttons of the de-soldering function to set the desired time. You can choose a time between 1 min and 60 min. If you set “0,” the standby function is switched off.
5. Confirm the settings by pressing the up button of the soldering function (**4**).

Fine-adjusting the soldering iron

The station is calibrated at the factory, but it may be necessary to readjust these settings from time to time. This can then be done by the following steps:

1. Turn on the soldering iron.



2. Set the temperature that you would like to calibrate, and place the soldering tip on an accurate external temperature sensor.
3. The results of the external sensor should roughly match those of the system.
4. If there are large differences between an external sensor and the display, the temperature sensor can be readjusted.
5. Switch off the soldering function on the station **(14)**; make sure that the de-soldering function is deactivated **(12)**.
6. Press and hold the up button of the de-soldering function **(4)**.
7. Release the button when the temperature display field of the soldering function **(14)** shows "000." You can now fine-adjust the soldering iron temperature.
8. You can use the temperature adjustment buttons to set the desired value.
9. The value "0" indicates that no values are added to the current temperature. A minus in the display field indicates that a value has been subtracted from the current temperature.
10. Confirm the settings by pressing the up button of the de-soldering function **(5)**.

Example:

- An external sensor shows 250 °C.
- The temperature set and displayed on the device is 300 °C.
- $300 - 250 = 50$; for the display to be correct again, 50 °C must be added.
- Put the device in calibration mode; the display shows "010."
- Set from "010" to "060" ($10 + 50 = 60$) by pressing the setting button **(4)**.
- Leave the calibration mode again.
- The display should now be correct again.

Fine-adjusting the de-soldering gun

The system is calibrated at the factory, but it may be necessary to readjust these settings from time to time. This can then be done by the following steps:

1. Turn on the de-soldering gun.
2. Set the temperature that you would like to calibrate and place the soldering tip on an accurate external temperature sensor.
3. The results of the external sensor should roughly match those of the system.
4. If there are large differences between an external sensor and the display, the temperature sensor can be readjusted.
5. Switch off the soldering function on the station **(14)**; make sure that the de-soldering function is deactivated **(12)**.
6. Press and hold the up button of the de-soldering function **(4)**.
7. Release the button when the temperature display of the soldering function **(14)** shows "000." You can now calibrate the temperature of the de-soldering iron.
8. You can use the temperature adjustment buttons to set the desired value.
9. The value "0" indicates that no values are added to the current temperature. A minus in the display field indicates that a value has been subtracted from the current temperature.
10. Confirm the settings by pressing the up button of the de-soldering function **(5)**.

Example:

- An external sensor shows 300 °C.
- The temperature set and displayed on the device is 350 °C.
- $300 - 350 = -50$; for the display to be correct again, it must be decreased by 50 °C.
- Put the device in calibration mode; the display shows "010."
- Set the displayed value from "010" to "040-" ($10 - 50 = -40$) by pressing the setting button **(5)**.
- Leave the calibration mode again.
- The display should now be correct again.

Maintenance

Spare parts

Name	Item number	Description
10094	90103	Hot air heating element
T002	90148	Handle tweezer with soldering tip
932.2	90198	Vacuum pick up kit for solder fume extraction
WQ/LF-52D	91537	Soldering station tip for soldering iron $\varnothing 5.2 \times 1.2$ mm
WQ/LF-24D	91534	Soldering station tip for soldering iron $\varnothing 2.4 \times 0.5$ mm
WQ/LF-KL	91514	Soldering station tip for soldering iron $\varnothing 4.7 \times 1.5$ mm
WQ/LF-LI	91510	Soldering station tip for conic soldering iron R0.1 mm
WQ/LF-LB	91508	Soldering station tip for conic soldering iron R0.2 mm
WQ/LF-2B	91504	Soldering station tip for conic soldering iron R0.5 mm
	91417	De-soldering tip $\varnothing 1.8$ mm, long shaft
	91415	De-soldering tip $\varnothing 1.0$ mm, long shaft
1325	91325	Hot air nozzle D1.5 \times 10 mm
1259	91259	Hot air nozzle SOP 13 \times 28 mm
1191	91191	Hot air nozzle SIP 25L 26 mm

Blower/vacuum air filters

The filters should be cleaned and changed regularly so that contamination does not block the air line. This is important for the toxic gases generated during soldering to be filtered without problems.

Soldering tip/iron

- Always keep the solder-coated area of the soldering tip coated with a small amount of solder.
- Oxide coatings on the tip can reduce thermal conductivity.
- The maximum thermal conductivity is obtained when the tip is coated with fresh solder.

Replacing the soldering tip

1. Always switch off the soldering station before replacing the soldering tip.
2. When the soldering tip is hot, use a heat-resistant pad to pull the soldering tip out.
3. Push the new soldering tip completely into the soldering iron. If the soldering tip is damaged or not placed correctly, "PLUG" appears on the display.

Replacing the hot air gun heating element

The heating element is in the middle part of the heat gun. Typically, the life of a heating element is around a year (under normal conditions).

1. Loosen the three screws that secure the handle.
2. Pull off the plastic tube.
3. Remove the earthing.
4. The quartz glass and thermal insulation are built into the inside of the heat gun. Disconnect the cable and pull out the heating element.

5. Insert the new heating element and reconnect the cable. Avoid any friction on the wire of the heating element.
6. Reconnect the earth after the heating element has been inserted.
7. Reinstall the handle.

Error display for the soldering iron

The soldering iron is not connected or not connected correctly.

The soldering tip is defective and must be replaced. "PLUG" appears on the display.

The contacts of the soldering iron or the soldering tip are damaged.

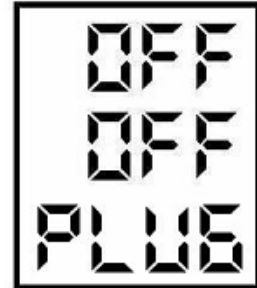

De-soldering gun

1. Moisten the filter pads before use so that they are particularly effective. It is recommended to rewet the pads regularly.
2. Clean the filter spring and change the filters if they are contaminated.
3. The solder line in the gun can be cleaned with the cleaning needle if necessary.

Exploded view and de-soldering gun parts list

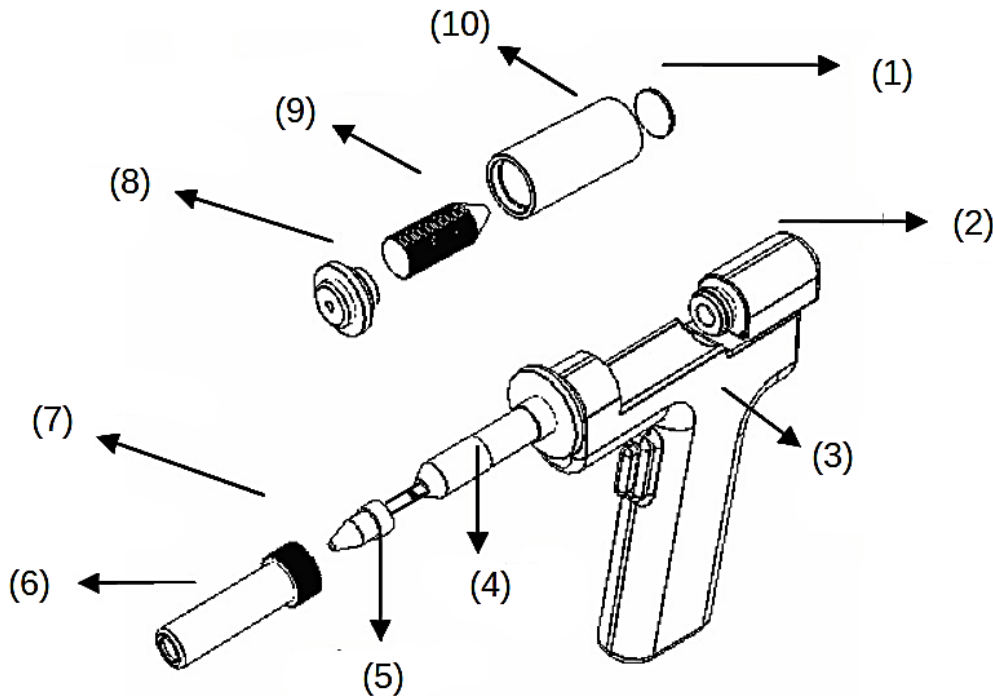

Nº	Name	Nº	Name
1	Filter pad	6	Heating element housing
2	Filter holder	7	Safety cap
3	Desolderin gun body	8	Filter pipe cap

4	Heating element	9	Filter spring
5	Nozzle	10	Filter pipe

Replacing the nozzle

Loosen the safety lock and pull out the housing of the heating element together with the safety lock. The nozzle can now be changed. Secure the nozzle by tightening the safety lock again.

Replacing the filter pad and the filter spring

Unlock the filter holder by pressing the eject knob. The filter holder is pushed out and enables the filter tube, which contains the filter pads, the filter spring and the filter tube cover, to be easily removed.

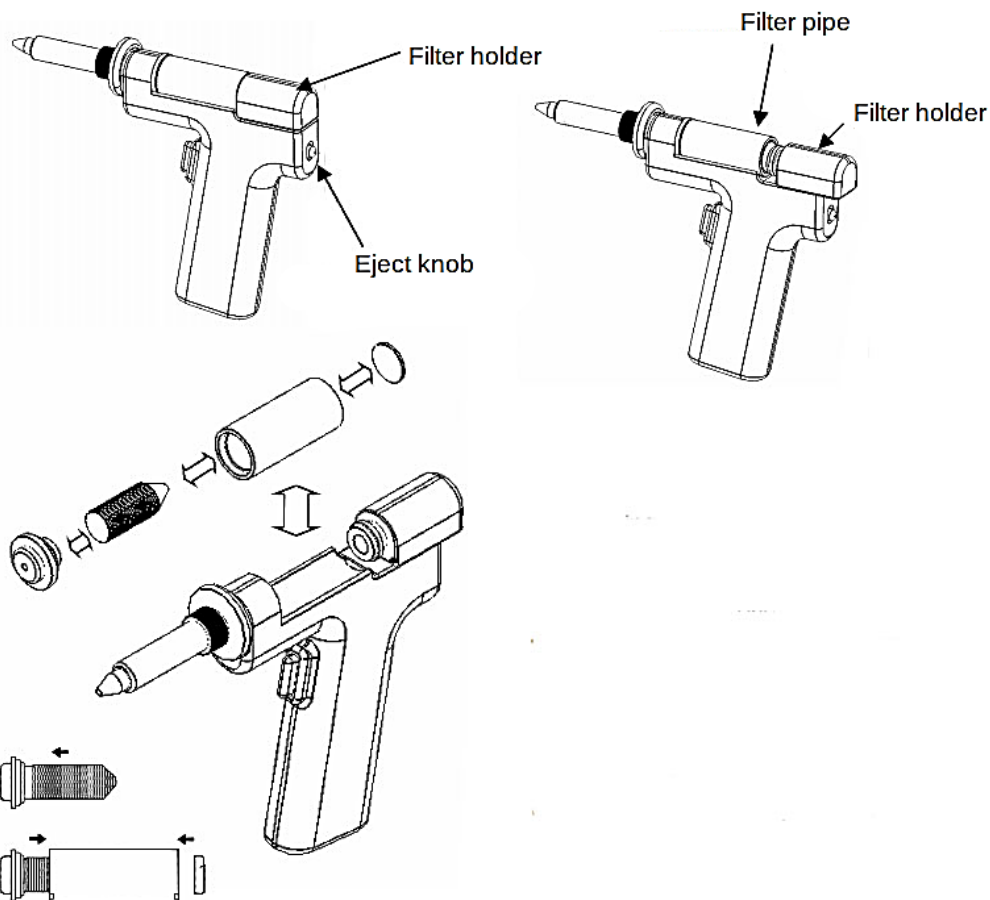

- After removing the filter tube, the filter pads and the filter spring can now be removed and cleaned or replaced.
- To reassemble the de-soldering gun, attach the spring to the filter tube flap and place the filter tube back on the gun body.
- Push the filter holder back into place until you hear a click, which means that the filter holder is secured again.

Checking and cleaning the de-soldering gun obstructed

1. Plug in the power plug, switch on the de-soldering function of the station and let the nozzle heat up.
2. Wait until the nozzle has heated up completely before you start cleaning.
3. Clean the opening of the nozzle with the cleaning needle.
4. If the cleaning needle does not fit through the opening, use a cleaning drill instead.

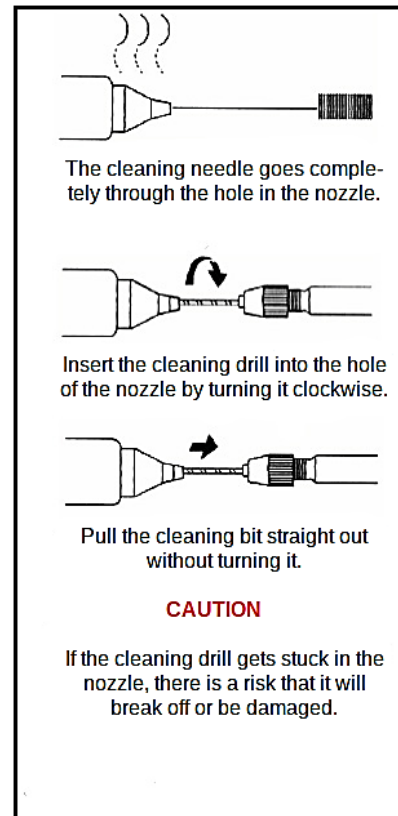

Checking the nozzle for signs of wear

1. Check the condition of the coating on the tip of the nozzle.
2. The inside of the nozzle and the surface are coated with a special alloy. If this alloy is damaged by high temperatures, the nozzle can no longer heat up properly and evenly.

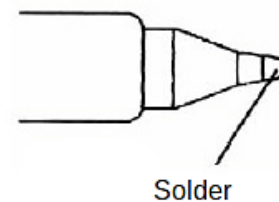

Replacing the heating element

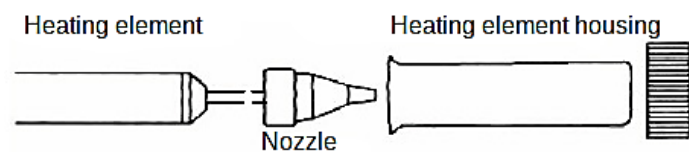

1. Loosen the lock and pull off the housing and nozzle.
2. Remove the old heating element and insert a new one.
3. Reinstall the nozzle and slide the housing back into place. Tighten the locking screw again properly so that no air can escape. If the locking screw is not tightened properly, the de-soldering gun can no longer heat up properly.

Checking the heating element, the connector, and the connections inside the soldering iron

To check whether the heating element or the sensor is possibly defective, a resistance measurement should be carried out in the event of problems (see figure below). The measurement must be carried out at normal room temperature and result in a value between 7.5 Ω and 12 Ω .

Measuring point



To check the soldering iron connector for damage, a resistance measurement should be carried out between the third pole of the connector and the tip of the soldering iron. The value must not exceed 2 Ω . If this is the case after cleaning the soldering tip, the connector is defective and must be replaced.

General remarks and maintenance

Care instructions for soldering tips

1. Soldering tip temperature – High temperatures shorten the life of the soldering tip and increase the heat load on the components during soldering. If possible, always use the lowest processing temperature recommended for your solder.
2. Cleaning – Always clean the soldering tip before use to remove excess solder and flux residues. Use a clean, wet cleaning sponge for this. Residues on the soldering tip can negatively affect the soldering process and lead to poor soldering results. Our soldering iron tip cleaner g1806 makes this work easier for you.
3. After use – Always clean the soldering tip and re-tin it before switching off. This protects the soldering tip from oxidation and increases the service life of your soldering tip.
4. Never leave the station switched on at high temperatures for long periods of time. Otherwise, the oxidation of the soldering tip will be stimulated. Switch off the device at the main switch if it is not used for several hours. If it is not going to be used for a long time, it is advisable to pull out the power plug as well.

Cleaning the soldering tip

Carry out this cleaning as often as possible (possibly daily) to increase the service life of the soldering tip.

- Set the temperature to around 250 °C.
- When the temperature has stabilised, clean the tip and check its condition. If it is badly worn or deformed, replace it.
- If the pre-tinned part of the soldering tip is covered with black oxide, apply new solder containing flux to the tip and clean it again. Repeat this process until all black oxidised areas are removed and then apply a new layer of tin.
- Switch off the station, let the soldering iron cool down and remove the soldering tip. Let the soldering tip cool down a bit.
- Remaining residues, e.g., yellow discoloration, can now be removed with isopropanol alcohol.



CAUTION: Never use a file to remove any residue!

De-soldering

1. Set the de-soldering switch to on.
 - a) Set the temperature.
 - b) Always set the temperature as low as possible.
 - c) To be able to set the temperature precisely, measure the temperature at the nozzle with a thermometer and adjust the temperature control.
2. The temperature can be set between 380 °C and 480 °C.



3. Wipe off old solder on the nozzle in the hole in the centre of the sponge (if the tip of the nozzle is stuck with old solder, it will no longer get hot; coat the nozzle with a thin layer of new solder to achieve optimal heating output).
4. Hold the nozzle to the soldered point and melt the solder.
 - a) Never touch the circuit board itself with the hot nozzle.
 - b) Make sure that the solder is properly melted (partially melted solder clogs the de-soldering gun).
 - c) Never try to force the solder to move. It moves very easily when melted, and if it does not move easily, that is a sign that the solder has not melted properly.
5. After confirming that the solder has melted, suck it up by pressing the trigger on the gun.
 - a) Hold the trigger pressed for one to two seconds longer so that no solder residue gets stuck in the supply lines and everything gets into the filter.
 - b) Do not leave any solder residue in the hole in the board.
 - c) After removing the solder, let the board cool down to prevent accidental de-soldering.
6. Clean the filter and moisten the sponge regularly during and after use to ensure consistent performance.
7. When finished work, switch off the de-soldering unit.
8. Before putting the device away, let the de-soldering gun cool down.

Pressure display

- The pressure indicator helps to resolve problems that may arise during de-soldering.
- Test the pressure gauge while the nozzle is open. Press the trigger and check the pressure gauge. If it is red, clean the nozzle and heating element, empty the filter tube, and replace the filter. If the indicator is blue, cleaning is not necessary and you can get on working.

**If the pressure indicator is blue or just a little red, no further action is necessary.
If the pressure indicator is more than half red, replace the filters and clean
the nozzle and the heating element.**

**Note: If the suction power of the de-soldering gun decreases significantly,
clean the nozzle and the heating element with the cleaning needle.**



CAUTION: Carry out maintenance work on the station only with the device switched off and the power plug pulled out!

Replacing the hot air heating element

The heating element is in the middle of the hot air iron. The normal service life is approximately 1 year under normal operating conditions.

- Loosen the 3 screws that hold the handle (Fig. I).
- Push the plastic tube to one side.
- Loosen the connection of the earthing cable.
- **Danger!** In the tube there is an easily breakable quartz glass as an insulation material that must not be damaged.
- Loosen the cable connections and remove the heating element.
- Insert the new heating element and re-establish the cable connections. Avoid touching the heating element or subjecting it to mechanical force, as this could damage it.
- Reconnect the earthing cable (Fig. II).
- Fasten and connect the connection terminals and the grounding cable. Make sure that the cables do not rub anywhere. Now the handle can be reassembled in reverse order.

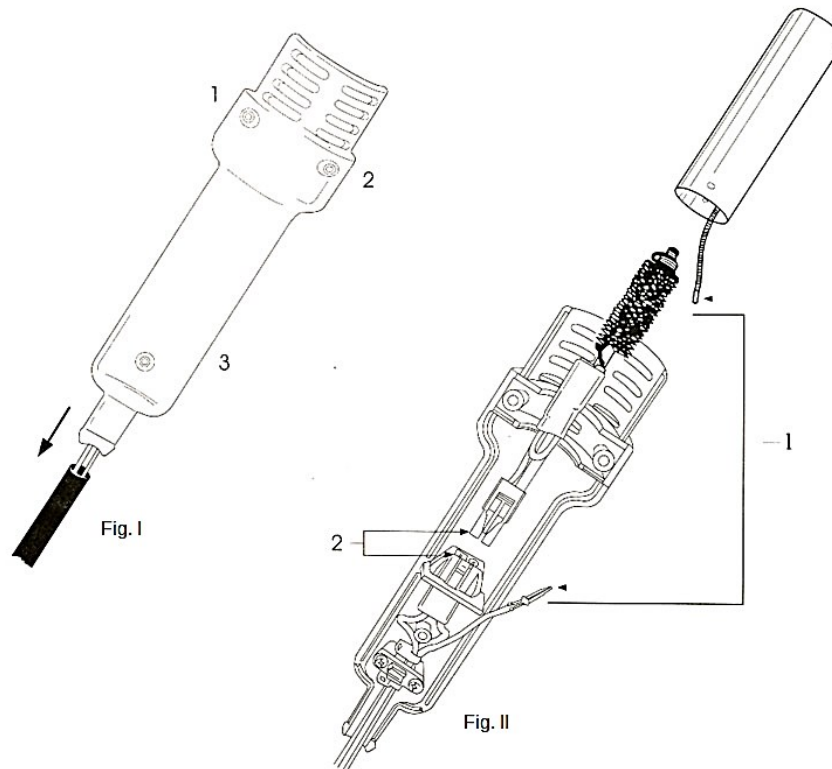

De-soldering and soldering with hot air

1. **Adjust the air flow and the temperature using the regulators provided.** After you have set the temperature and the air flow using the corresponding control buttons, the station needs a short time to reach the set temperature. A temperature value between 300 °C and 350 °C is recommended. If you are working with single nozzles, it is recommended to set the air flow to levels 1 to 3. Levels 4 to 6 are also provided for other nozzles. The temperature setting must not exceed level 5 when working with single nozzles.
2. **Place the component holder under the IC element to be de-soldered.** Adjust the distance between the holder sides of the component holder to the width of the component to be de-soldered.
3. **Melt the solder.** Hold the handle so that the nozzle is exactly above the component to be de-soldered. The nozzle must not touch either the component or its contacts directly.
4. **Remove the component to be de-soldered.** After the solder has melted, the component can easily be lifted off the board with the help of the component holder.
5. **Switch off the soldering station using the main switch.** After you have turned on the main switch, the automatic cooling function of the device starts. The handle and heating element are cooled with cold air. This process must not be interrupted by pulling the power plug, otherwise the service life of the device will be greatly impaired.
6. **Remove any remaining solder.** After you have removed the component from the board, the remaining solder should also be removed from the board with the help of an appropriate tool.

Soldering

1. **Apply solder paste.** To solder the component (e.g., SMD) onto a circuit board, you need an adequate amount of solder paste.
2. **Solder.** Heat the component and the conductor connections.
3. **Clean the circuit board.** Once you have completed the soldering process, the board should be cleaned and the flux removed.

Troubleshooting

1st problem: The station has no electricity.

Solutions:

- a) Check to see if the station is turned on.
- b) Check the fuse. If it is burned out, it must be replaced.
- c) Check the cable. Make sure that it is properly connected.

2nd problem: The hot air temperature display always shows a temperature above 500 °C; after a short time, it shows “Err 1.”

Solution: The temperature sensor is defective and must be replaced.

3rd problem: The actual air temperature of the hot air iron does not decrease or increase based on the desired target temperature.

Solution: The heating element is defective or worn and needs to be replaced.

4th problem: The station vibrates too much.

Solution: Check that the four screws that hold the pump in place are properly and securely in place. Unplug the station from the mains before opening the station to look inside.

5th problem: The station is very loud.

Solution: Make sure that the security screw located in the centre of the station bottom has been removed. This screw secures the pump during transport and must be removed before using the station.

6th problem: The soldering iron temperature display shows “PLUG”.

Solutions:

- a) Check that the soldering iron has been inserted correctly.
- b) Make sure that the soldering tip is properly inserted and properly secured inside the handle. Loose contacts can also be a reason for an error message.

7th problem: The air pressure is clearly too low, no matter how high it has been set.

Solutions:

- a) Case 1: Check the mains voltage. If the voltage is 15–20 % lower than the standard, the air pressure will also drop. Contact your electricity provider.
- b) Case 2: The microcontroller could have incorrectly recognised the operating frequency. The user might notice that the air pressure is weaker than the measured value. Switch the station off and on again so that the value can be read out again.

8th problem: The station behaves unusually; it works irregularly.

Solutions:

- a) Switch the station off and on again. Also disconnect the station from the mains once and then plug the cable back in.
- b) Restore the factory settings of the station. Switch the device on and off while holding down the “reduce hot air temperature” button. Wait until the display has finished tickering so that the device is reset to the factory settings.

Disposal regulations

EU guidelines regarding the disposal of scrap electric appliances (WEEE, 2012/19/EU) were implemented in the law related to electrical and electronic equipment and appliances.

All WiITec electric devices that fall under the WEEE regulations are labelled with the crossed-out wheeled waste bin logo. This logo indicates that this electric equipment must not be disposed with the domestic waste.

The company WiITec Technik GmbH has been registered in the German registry EAR under the WEEE-registration number DE45283704.

Disposal of used electrical and electronic appliances (intended for use in the countries of the European Union and other European countries with a separate collection system for these appliances).

The logo on the article or on its packaging points out that this article must not be treated as normal household waste but must be disposed to a recycling collection point for electronic and electrical waste equipment. By contributing to the correct disposal of this article you protect the environment and the health of your fellow men. Environment and health are threatened by inappropriate disposal.



Material recycling helps reduce the consumption of raw materials.

Additional information on recycling this article can be provided by your local community, municipal waste disposal facilities, or the store where you purchased the article.

Address:
WiITec Wildanger Technik GmbH
Königsbenden 12 / 28
D-52249 Eschweiler

Important notice:

The reprint or reproduction, even of excerpts, and any commercial use, even in part, of this instruction manual require the written permission of WiITec Wildanger Technik GmbH.