



## Intelligent Lighting and Control Solutions

*Enabling Innovation in Lighting*



# Intelligent Lighting and Control

## Summary

Microchip can meet the technical needs of lighting engineers with its large array of 8-, 16-, 32-bit PIC® microcontrollers, analog, wireless, and human interface products. With advanced peripheral integration and support for all lighting technologies, a scalable Microchip solution provides significant flexibility versus that of a pure analog or ASIC implementation. Designing with Microchip-based intelligent lighting solutions and control enables innovation that expands lighting product capabilities and provides product differentiation.

Light-emitting diode (LED) and fluorescent technologies are currently at the forefront of delivering the most efficient alternatives to incandescent lighting. Although both pose technical challenges, they also offer significant advantages beyond simple incandescent light bulb replacement, including improved efficacy (lumens/watt), reduced energy consumption and the ability to add intelligence.



Because the light quality of these alternate lighting technologies is perceived to be similar to that of incandescent lighting, the benefits of longer life and increased energy savings may not always be considered significant enough to motivate changes in the market. Microchip's advanced lighting solutions offer you the opportunity to incorporate non-traditional capabilities into your lighting designs. Features such as predictive failure and maintenance, energy monitoring, color and temperature maintenance and remote communications and control are just some of the advanced capabilities that can make intelligent lighting solutions more attractive. These advanced capabilities—along with reduced operating, maintenance and energy costs—can quickly translate to significant savings, particularly for corporate and commercial facilities.

## Value Proposition

Microchip-based lighting solutions provide opportunities to further enhance any lighting application through product differentiation and an improved user experience.

### Intelligence

- Communication and networking
- Lumen and color control
- Environmental sensing
- Thermal management
- Predictive failure and maintenance
- Daylight harvesting
- Smooth dimming control
- Color mixing
- Closed loop lighting control
- Remote fault detection
- User interface and control

### Flexible Power

- Flexible power topology support
- High efficiency power conversion
- Failsafe monitoring
- Energy monitoring and control
- Energy harvesting (e.g. solar)
- Battery management and charging

### Scalable Design

- Scalable performance
  - 8-, 16-, 32-bit PIC MCUs
  - Analog products
  - Wireless ICs and modules
  - Human interface products
- Customizable solutions
- Ease of use
  - Easy-to-use development tools
  - Reference designs and collateral
  - Lighting design partner specialists



## Learn More

Microchip offers various resources to assist you in your next product design. Learn more about Intelligent Lighting and Control solutions from Microchip by visiting us on the web at: [www.microchip.com/lighting](http://www.microchip.com/lighting) or emailing us at: [lighting@microchip.com](mailto:lighting@microchip.com).

# Lighting Technology Basics

## Incandescent Lighting Technology

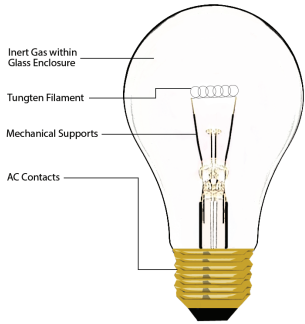

Advantages	Disadvantages
<ul style="list-style-type: none"> <li>■ Cheap</li> <li>■ Large amounts of visible light</li> <li>■ No electronics required</li> </ul>	<ul style="list-style-type: none"> <li>■ Poor efficiency                             <ul style="list-style-type: none"> <li>• ~10% input energy = light</li> <li>• ~90% input energy = radiated heat</li> <li>• 10–30 lumens/watt (efficacy)</li> </ul> </li> <li>■ Short life: 1,000–2,000 hours</li> </ul>

Incandescent light sources are good at creating large amounts of visible light and even greater amounts of heat. As a result, a typical light bulb is not very efficient—only about 10% of the input energy is output as light with the remaining 90% being wasted as radiated heat. The typical light bulb has a relatively short lifetime—ranging from several hundred to a couple thousand hours—as the extreme heat of the tungsten causes it to evaporate and eventually fail.

## Fluorescent Lighting and HID Technology

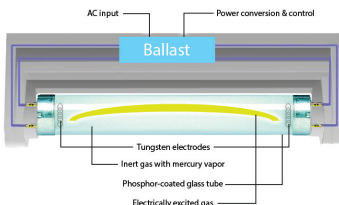

Advantages	Disadvantages
<ul style="list-style-type: none"> <li>■ Relatively inexpensive                             <ul style="list-style-type: none"> <li>• ~75% less energy than incandescent</li> <li>• More than 70 lumens/watt (efficacy)</li> </ul> </li> <li>■ Increased life: &gt; 8,000 hours</li> </ul>	<ul style="list-style-type: none"> <li>■ Typically requires “warm up”</li> <li>■ Can contain mercury</li> <li>■ Sensitive to environment and orientation</li> <li>■ Moderate light quality</li> </ul>

Typical fluorescent lighting operates by driving a current through a glass enclosure containing an inert gas and mercury. With the help of phosphors, these elements create visible light when they are excited by electricity. High intensity discharge (HID) lamps or arc lamps are similar in function but create visible light through electrically excited gases (plasma) without the use of phosphors. In both glow-discharge lamps and HID lamps, a ballast is required to initiate and maintain this electrical reaction. The ballast kick-starts the electrical-gas reaction with a large amount of energy and then regulates the current back down to a normalized operating current. High-resolution PWM control is required to accurately control this reaction as well as provide smooth dimming control.

## LED Lighting Technology

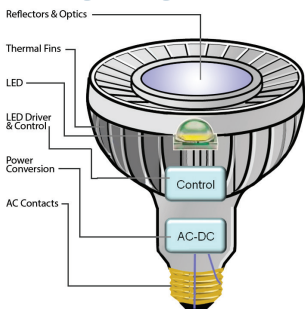

Advantages	Disadvantages
<ul style="list-style-type: none"> <li>■ Best overall efficiency                             <ul style="list-style-type: none"> <li>• ~25–50% less energy than fluorescent</li> <li>• More than 100 lumens/watt (efficacy)</li> </ul> </li> <li>■ Longest life: &gt; 50,000 hours</li> <li>■ No “warm up”, no radiated heat</li> <li>■ Good in indoor and outdoor applications</li> </ul>	<ul style="list-style-type: none"> <li>■ Requires active or passive thermal solution to remove conducted heat</li> </ul>

Similar to a traditional LED, a High Brightness Light Emitting Diode (HBLED) produces light when forward biased, enabling the electron-hole recombination that releases light photons. LED light output is a direct function of the current flow—too little current and the light will dim, too much current and lifetimes will be shortened. A typical LED driver is a DC power supply providing converted AC or DC power to directly control the LED via constant current, Pulse Width Modulation (PWM), or other variations. The LED driver must also provide high efficiencies and power factor correction (PFC) while providing protection from AC line voltage fluctuations.

LED drivers can be designed to offer dimming and RGBW color mixing capabilities by either providing a high resolution PWM (or variants such as VFM—Variable Frequency Modulation) signal or varying the constant current.

### Constant Current Method

- Light output maintained by constant current level
- Dimming control via varying current level
- Requires high resolution current control

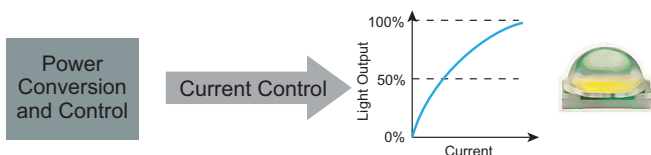

### Modulated Current Method

- Fixed current drive chopped by PWM
- Dimming control via varying PWM duty cycle



# Efficient Power Conversion for Ballasts and Drivers

Microchip-based solutions can support any lighting technology as well as add capabilities beyond those of traditional lighting solutions. The flexibility of these solutions allows for simplified attachment to existing designs or the development of full Switch Mode Power Supply (SMPS) based intelligent solutions—and everything in between.

## PIC MCU Attached to Basic Power Supply

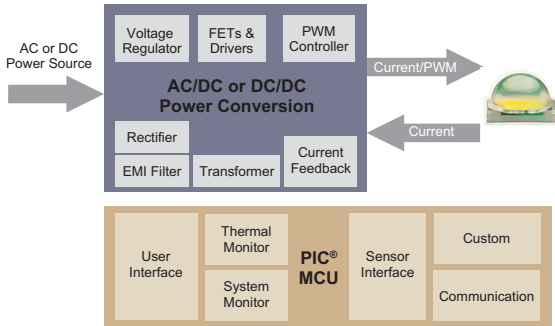

- Simplified design-in
- Customizable features
- Simplified modifications via firmware updates
- Intelligent control capabilities

## SMPS with PIC MCU and Microchip Analog

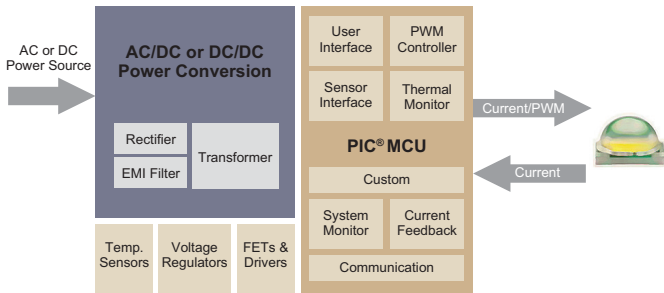

- Increased MCU integration
- Fully customizable
- Increased efficiency
- Power Factor Correction (PFC)
- Flexible topologies
- Simplified modifications via firmware updates
- Closed loop control
- High performance PWM and current control
- Intelligent control capabilities

## Energy Harvesting and Battery Charging

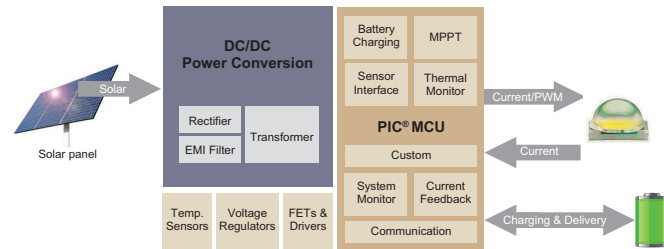

- PIC MCU controlled power conversion and battery storage
- Peak power tracking control, charging and power delivery
- Customizable Maximum Power Point Tracking (MPPT) and battery charging algorithms
- Support for various power supply topologies
- Intelligent control capabilities

The SMPS topologies utilized to regulate the power within lighting applications are the same used within a power supply application. Each SMPS topology has its advantages and determining the proper topology is dependent upon the specific application requirements.

## SMPS Topologies

Topology	V <sub>IN</sub> vs. V <sub>OUT</sub> Relationship	Maximum Power Range	Peak Efficiency
Buck	V <sub>IN</sub> > V <sub>OUT</sub>	1000W	> 90%
Boost	V <sub>IN</sub> < V <sub>OUT</sub>	150W	> 90%
Buck/Boost	V <sub>OUT</sub> < V <sub>IN</sub> < V <sub>OUT</sub>	150W	> 80%
SEPIC. Cuk. Zeta	V <sub>OUT</sub> < V <sub>IN</sub> < V <sub>OUT</sub>	150W	> 90%
Flyback	V <sub>OUT</sub> < V <sub>IN</sub> < V <sub>OUT</sub>	150W	> 80%
Resonant	V <sub>OUT</sub> < V <sub>IN</sub> < V <sub>OUT</sub>	500W	> 90%
Push-Pull	V <sub>OUT</sub> < V <sub>IN</sub> < V <sub>OUT</sub>	1000W	> 90%

# Intelligent Lighting Controls

No matter which lighting technology is used, the ability to effectively control the light source is essential. Replacing a simple on/off switch, advanced lighting control provides the opportunity to incorporate additional intelligence and increase energy savings.

The ability to dim any light source is the most common requirement of a light controller, but it is also a potential design obstacle. Most legacy dimmers are simple TRIAC dimmers that can vary the light output of an incandescent light source from 0–100%. These vary the brightness by “chopping” the AC line voltage and controlling the effective power to the lamp, thereby varying the light output. This method functions well with incandescent sources, as well as with some specially designed CFL ballasts, but does not function properly with most conventional drivers or ballasts. In order to effectively dim LED and fluorescent light, specialized methods such as varying PWM frequency or variable current is required. This is easily implemented with electronic dimming controllers.

Functions such as dimming and timers are becoming commonplace, but intelligent control provides opportunities to enrich the user experience and increase value. Incremental energy savings can be provided by integrating elements such as energy management and harvesting (ie. solar), ambient light compensation (reducing light output based on other localized light sources) and occupancy or motion sensing. Intelligent control enables the creation of lighting networks that communicate locally as well as to remote locations to increase energy savings further and reduce maintenance cost via items such as fixed light output in lighting arrays (ie. street lamps, large rooms, etc.), monitoring light output and providing real-time operating issues. Lighting can also be integrated into other system topologies including security systems or automation and control. Aesthetically, lighting control supports custom mood lighting designs which can vary brightness, color and color temperature across large lighting arrays.

Using Microchip’s intelligent light and control solutions, you can integrate a variety of enhanced capabilities into the luminaire ballast/driver, wall controller or remotes to create additional product differentiation. You are limited only by your creativity in designing differentiated products that offer customizable user interfaces and improved user experience.

## Legacy Control



### Non-Intelligent Lighting Control

- Mechanical interface
- Limited luminaire control
- No user feedback
- No communication
- No product differentiation

## Intelligent Control



### mTouch™ Capacitive Touch (all PIC MCU families)

- Metal over cap capability
- Projected capacitive capability

### Segmented LCD (PIC16, PIC18, PIC24)

- Up to 480 segments
- Low power display modes
- Contrast control

### Graphics (PIC24, PIC32, dsPIC DSC)

- Integrated graphics controllers
- Direct drive for QVGA and W-QVGA

### Audio (PIC18, PIC24, PIC32, dsPIC DSC)

- Mode for iPod® and Android™ accessories

### Communication (all PIC MCU families)

- Intelligent luminaire control
- DALI, DMX512, LIN/CAN, wireless, others...
- FREE code libraries

### Gesture Control (GestIC® Technology)

- Recognition of 3D hand gestures

# Communications and Networking

Microchip solutions provide the versatility to support legacy lighting communications protocols as well as protocols that are just emerging in the lighting industry. Our FREE code libraries and examples for PIC MCUs help you quickly add a wide array of communication options to any lighting application. The versatility of a Microchip-based solution enables the creation of customized communications gateways and networks that allow for interoperability of multiple protocols.

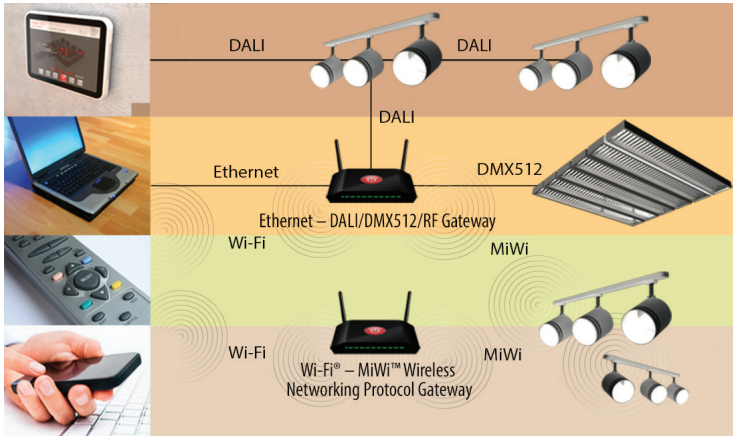

## Wired Protocols

- DALI
- DMX512A
- 0–10V
- PLC
- LIN
- CAN
- RS232/RS485
- USB LS/FS
- Ethernet

## Wireless Protocols

- Wi-Fi 802.11 modules
- Bluetooth®
- ZigBee®
- MiWi™ wireless networking protocol 802.15.4 modules
- Stacks for PIC MCUs
- Infrared/IrDA®

## 0–10V

0–10V is the simplest and most prevalent lighting communication protocol. Scaling from 0 to 10V, communication is based on varying the voltage levels. This is useful for dimming, as well as responding to external input sources, such as sensors, remotes, wall-box controls and automation.

## Digital Addressable Lighting Interface (DALI)

DALI is a standard lighting control protocol for large networked lighting systems. DALI provides bi-directional communications with uniquely addressed light sources. This allows for customized lighting schemes and the ability for the light source to relay output level, color and other information back to the controller. Microchip offers FREE DALI code libraries to simplify development—available at [www.microchip.com/lightingcomms](http://www.microchip.com/lightingcomms).

## Digital Multiplex 512 bytes (DMX512)

DMX512A is another successor to 0–10V which provides dimming communication. Used heavily within stage and theatrical lighting applications, DMX512A provides unidirectional lighting communication and control of various stage effects. Microchip offers FREE DMX512A code libraries to simplify development—available at [www.microchip.com/lightingcomms](http://www.microchip.com/lightingcomms).

## CAN and LIN

CAN and LIN protocols were originally created for the automotive market. CAN was designed as a high-reliability and high-speed protocol (up to 1 Mbit/s) for the harsh environment of the car electrical bus. LIN was later added as a simple low-cost alternative for the control of non-critical modules on a vehicle. Due to their inherent robustness, these protocols are becoming more commonly used in non-automotive applications, specifically within industrial and commercial lighting environments. Learn more at [www.microchip.com/LIN](http://www.microchip.com/LIN) and [www.microchip.com/CAN](http://www.microchip.com/CAN).

## Ethernet

Ethernet connectivity is becoming ubiquitous. As lower-cost solutions are now more available, it is becoming easier to use Ethernet for even the simplest control and diagnostic applications. Learn more at [www.microchip.com/ethernet](http://www.microchip.com/ethernet).

## ZigBee

ZigBee is an industry standard protocol for wireless networking. Specifically designed for low-cost and relatively low-bandwidth automation applications, it allows for quick deployment of flexible network topologies including star, cluster and mesh. Learn more at [www.microchip.com/zigbee](http://www.microchip.com/zigbee).

## MiWi Wireless Networking Protocol

The MiWi wireless networking protocol is the most cost-effective wireless protocol designed for low-data-rate, short-distance, low-cost networks. Fundamentally based on IEEE 802.15.4™ for wireless personal area networks (WPANs), the MiWi wireless networking protocol is Microchip's proprietary RF protocol with FCC-certified modules—providing an easy-to-use and low-cost alternative for wireless communication. Learn more at [www.microchip.com/miwi](http://www.microchip.com/miwi).

## Wi-Fi

Wi-Fi is the most common of all wireless protocols. Microchip's Wi-Fi modules have been architected to ease integration at minimum system cost. FCC-certified modules are readily available to minimize design effort and time. Learn more at [www.microchip.com/wireless](http://www.microchip.com/wireless).

# Scalable Product Solutions

## Scalable Product Solutions

8-bit PIC® Microcontrollers (PIC18, PIC16, PIC12, PIC10)	16-bit/32-bit PIC Microcontrollers (PIC32, dsPIC® DSC, PIC24)	Analog	Wireless
<ul style="list-style-type: none"> <li>■ Luminaire ballast and LED drivers</li> <li>■ Wall and remote controls</li> <li>■ Intelligent control capabilities</li> <li>■ Communication and networking</li> <li>■ &lt; 100W Optimized power conversion</li> <li>■ Lowest cost</li> <li>■ Smallest form factors</li> </ul>	<ul style="list-style-type: none"> <li>■ Advanced controllers and luminaires</li> <li>■ Advanced communication and networking                             <ul style="list-style-type: none"> <li>· RF gateway and translators</li> <li>· Power line carrier (PLC)</li> </ul> </li> <li>■ Advanced intelligent control capabilities</li> <li>■ &gt; 100W Advanced power conversion</li> <li>■ Increased performance</li> <li>■ Increased lighting channels</li> </ul>	<ul style="list-style-type: none"> <li>■ High-voltage offline LED driver ICs</li> <li>■ Broad portfolio of DC/DC power conversion solutions</li> <li>■ SMBus and I<sup>2</sup>C™ temperature sensors</li> <li>■ Highly configurable PWM controllers</li> <li>■ Complementary PIC MCU compatible regulators, drivers and sensors</li> </ul>	<ul style="list-style-type: none"> <li>■ Wi-Fi® 802.11 modules</li> <li>■ ZigBee® RF4CE</li> <li>■ MiWi™ Wireless Networking Protocol 802.15.4 modules</li> <li>■ Infrared/IrDA®</li> </ul> 

## Focus Peripherals Integration

Microchip is a leading provider of microcontrollers by continually investing and expanding upon its extensive line of PIC microcontrollers. Emphasis is constantly focused on reducing costs while developing products with a strong mix of digital and analog peripherals such as LCD drive, DACs, op amps, PWMs, ADCs, comparators, timers and communication. In addition to the standard peripherals, Microchip continuously brings additional value to PIC microcontrollers by developing unique and exclusive peripherals. These unique peripherals allow you to simplify your embedded lighting designs and develop more creative applications and products. The following PIC microcontroller's integrated peripherals are available to assist you in designing innovative lighting products. Learn more about Microchip's "Core Independent Peripherals" at [www.microchip.com/CIP](http://www.microchip.com/CIP).

## Peripheral Summary

Peripheral	Capability	Product Integration
High Resolution PWM (HRPWM)	Smooth dimming, accurate color mixing	All PIC® microcontrollers with NCO and CLC
Programmable Switch Mode Controller (PSMC)	Efficient, autonomous power conversion	PIC16F178X Family
Complementary Output Generator (COG)	Automated complementary output for simplified design of high-efficiency LED drive circuits	PIC12F752, PIC16F785
Complementary Waveform Generator (CWG)	Non-overlapping waveform generator for versatile lighting control	PIC10F32X Family, PIC16F150X Family
Numerically Controller Oscillator (NCO)	Precision linear frequency generator for building power conversion function	PIC10F32X Family, PIC16F150X Family
Configurable Logic Cell (CLC)	Configurable combinational and sequential logic for combining functional blocks in lighting driver and control systems	PIC10F32X Family, PIC16F150X Family
Hardware Limit Timer	Hardware monitoring for fault detection in lighting systems	PIC16F161X Family, PIC12F752, PIC12F753
Zero Crossing Detect (ZCD)	Precise dimming and switching control	PIC16161X Family, PIC16170X Family, PIC16171X Family
Slope Compensation	Performs slope compensation function for Peak Current Mode LED drivers	PIC16F753

# Scalable Product Solutions

## High Resolution PWM (HRPWM)

- > 16-bit effective PWM resolution at high frequency (eg. ~ 16-bit @ 500 kHz)
- Requires Numerically Controlled Oscillator (NCO) and Configurable Logic Cell (CLC)
- Improved EMI performance
- Higher frequency operation
- Results in reduced sizing of inductors and capacitors
- Application Note: AN1476 – Combining the CLC and NCO to Implement a High Resolution PWM

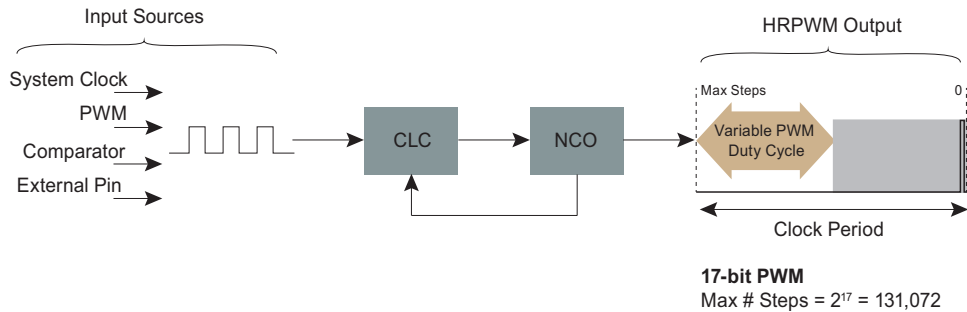

## Conventional PWM vs. HRPWM

	Conventional PWM	HRPWM
PWM Resolution	16-bit	variable
PWM Clock Frequency	16 MHz	16 MHz
Target Switching Frequency	500 kHz	500 kHz
Target Period Width	$1 + 500 \text{ kHz} = 2 \mu\text{s}$	$1 + 500 \text{ kHz} = 2 \mu\text{s}$
Best PWM Pulse Adjustment	$1 + 16 \text{ MHz} = 62.5 \text{ ns}$	$15.26 \text{ ps}^{**}$
Maximum # of Steps per Period	$2 \mu\text{s} + 62.5 \text{ ns} = 32$	$2 \mu\text{s} + 15.26 \text{ ps} = 131,072$
Effective Full Range PWM Resolution	$\log_2 32 = 5 \text{ bits}$	$\log_2 131,072 = 17 \text{ bits}$

\*\*Reference Application Note AN1476

## Programmable Switch Mode Controller (PSMC)

- Single 16-bit PWM with up to six steerable outputs
- Complementary 16-bit PWM with up to three steerable output pairs
- Clock sources: external, system clock, independent 64 MHz oscillator
- Input sources: comparators, external pins
- Blanking control for transient filtering **1**
- Independent rising/falling edge control **2**
- Dead band with independent rise and fall control **3/4**
- Polarity control/auto shutdown and restart
- Flexible PWM output modes
- Burst Mode: externally control activate/deactivate

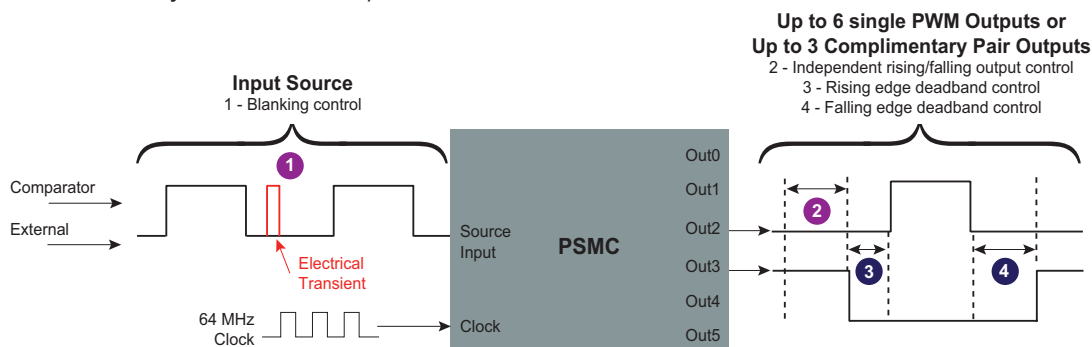



# Scalable Product Solutions

## Complementary Waveform Generator (CWG)/Complementary Output Generator (COG)

- Provides non-overlapping complementary waveform
- Various input sources including comparators, PWM, CLC, NCO
- Blanking control for transient filtering **1** (COG only)
- Phase control for output delay **2** (COG only)
- Independent rise and fall **3/4**
- Dead band control
- Auto shutdown/restart
- Polarity control

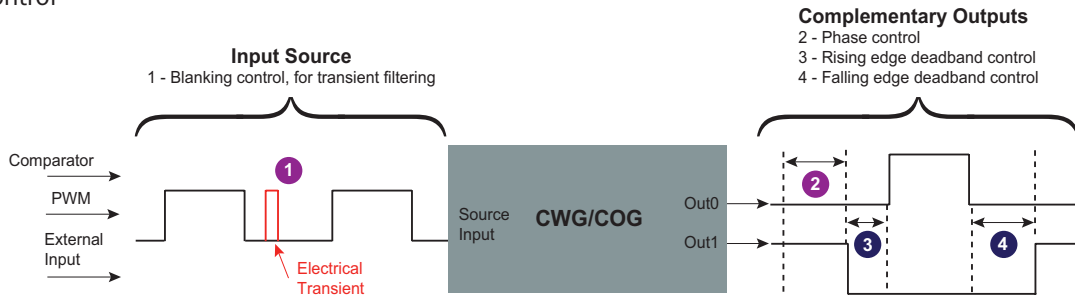

## Numerically Controlled Oscillator (NCO) Oscillator Capabilities with True Linear Frequency Control

### Key Features

- Up to 20-bit frequency resolution
- Multiple internal and external clock sources available
- 16-bit numeric frequency control
  - 625 kHz max output with 20 MHz oscillator
  - 0.03 Hz min step size with 31 kHz internal oscillator
- Two Output modes
  - Fixed 50% duty cycle **1**
  - Pulse Frequency Modulation (PFM) **2**

### Benefits

- True linear frequency control
- Increased frequency resolution
- Smooth fluorescent ballast dimming control

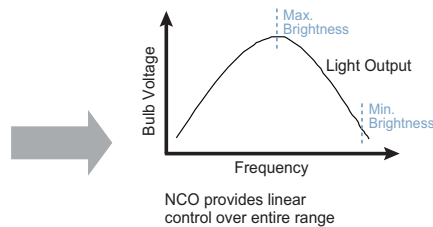
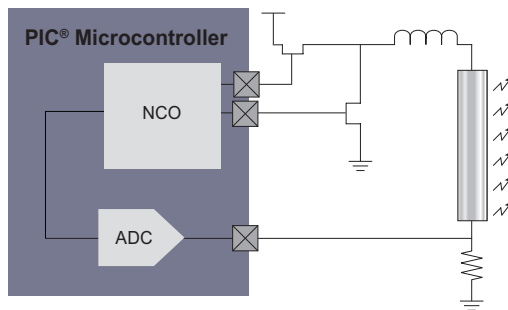
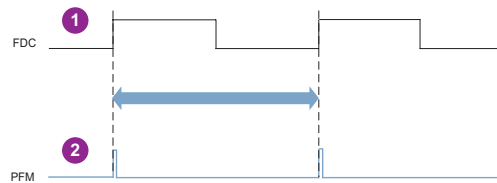

## Configurable Logic Cell (CLC)

- User-configurable real-time logic control
  - CLC configuration GUI for quick turn development
- Combinational logic functions
  - AND/OR/XOR/NOT/NAND/NOR/XNOR
- State Functions/Clock
  - D Flip-Flop, JK Flip-Flop D Latch, SR Latch
- Input source from external pins and peripherals
- Output available to external pins and peripherals
- Operation while in Sleep

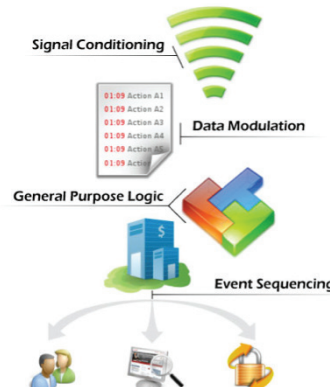

# Focus Microchip Products

## Focus PIC® Microcontrollers

8-BIT PIC® MICROCONTROLLERS															
Device	Flash Memory (B)	Pins	ADC	Comparator	Op Amps	DAC (5b/8b/9b/10b)	PWM (10b/16b)	CLC	NCO	CWG/COG	PSMC	HRPWM	Slope Compensation	ZCD	High-Current Drive (50 mA/100 mA)
PIC10F320	448	6	3 × 8-bit	-	-	-	2/0	1	✓	✓	-	✓	-	-	-
PIC10F322	896	6	3 × 8-bit	-	-	-	2/0	1	✓	✓	-	✓	-	-	-
PIC12F1501	1.75K	8	4 × 10-bit	1	-	1/0/0/0	4/0	2	✓	✓	-	✓	-	-	-
PIC16F1503	3.5K	14	8 × 10-bit	2	-	1/0/0/0	4/0	2	✓	✓	-	✓	-	-	-
PIC16F1507	3.5K	20	12 × 10-bit	-	-	1/0/0/0	4/0	2	✓	✓	-	✓	-	-	-
PIC16F1508	7K	20	12 × 10-bit	2	-	1/0/0/0	4/0	4	✓	✓	-	✓	-	-	-
PIC16F1509	14K	20	12 × 10-bit	2	-	1/0/0/0	4/0	4	✓	✓	-	✓	-	-	-
PIC12F1571	1.75K	8	4 × 10-bit	1	-	1/0/0/0	0/3	-	-	✓	-	-	-	-	-
PIC12F1572	3.5K	8	4 × 10-bit	1	-	1/0/0/0	0/3	-	-	✓	-	-	-	-	-
PIC12F(HV)752	1.75K	8	4 × 10-bit	2	-	1/0/0/0	1/0	-	-	✓	-	-	-	-	✓
PIC16F(HV)753	3.5K	14	8 × 10-bit	2	1	0/0/1/0	1/0	-	-	✓	-	-	✓	-	✓
PIC12F1612	3.5K	8	4 × 10-bit	1	-	0/1/0/0	2/0	-	-	✓	-	-	-	✓	-
PIC16F1613	3.5K	14	8 × 10-bit	2	-	0/1/0/0	2/0	-	-	✓	-	-	-	✓	-
PIC16F1614	7K	14	8 × 10-bit	2	-	0/1/0/0	2/0	2	-	✓	-	-	-	✓	✓
PIC16F1615	14K	14	8 × 10-bit	2	-	0/1/0/0	2/0	2	-	✓	-	-	-	✓	✓
PIC16F1618	7K	20	12 × 10-bit	2	-	0/1/0/0	2/0	4	-	✓	-	-	-	✓	✓
PIC16F1619	14K	20	12 × 10-bit	2	-	0/1/0/0	2/0	4	-	✓	-	-	-	✓	✓
PIC16F1703	3.5K	14	12 × 10-bit	-	2	-	2/0	-	-	-	-	-	-	✓	-
PIC16F1704	7K	14	12 × 10-bit	2	2	0/1/0/0	4/0	3	-	✓	-	-	-	✓	-
PIC16F1705	14K	14	12 × 10-bit	2	2	0/1/0/0	4/0	3	-	✓	-	-	-	✓	-
PIC16F1707	3.5K	20	12 × 10-bit	-	2	-	2/0	-	-	-	-	-	-	✓	-
PIC16F1708	7K	20	12 × 10-bit	2	2	0/1/0/0	4/0	3	-	✓	-	-	-	✓	-
PIC16F1709	14K	20	12 × 10-bit	2	2	0/1/0/0	4/0	3	-	✓	-	-	-	✓	-
PIC16F1713	7K	28	17 × 10-bit	2	2	1/1/0/0	4/0	4	✓	✓	-	✓	-	✓	-
PIC16F1716	14K	28	17 × 10-bit	2	2	1/1/0/0	4/0	4	✓	✓	-	✓	-	✓	-
PIC16F1718	28K	28	17 × 10-bit	2	2	1/1/0/0	4/0	4	✓	✓	-	-	-	✓	-
PIC16F1717	14K	40	28 × 10-bit	2	2	1/1/0/0	4/0	4	✓	✓	-	✓	-	✓	-
PIC16F1719	28K	40	28 × 10-bit	2	2	1/1/0/0	4/0	4	✓	✓	-	✓	-	✓	-
PIC16F1782	3.5	28	11 × 12-bit	3	2	0/1/0/0	0/2	-	-	-	2	-	-	-	-
PIC16F1783	7K	28	11 × 12-bit	3	2	0/1/0/0	0/2	-	-	-	2	-	-	-	-
PIC16F1784	7K	40	14 × 12-bit	4	3	0/1/0/0	0/3	-	-	-	3	-	-	-	-
PIC16F1786	14K	28	11 × 12-bit	4	2	0/1/0/0	0/3	-	-	-	2	-	-	-	-
PIC16F1787	14K	40	14 × 12-bit	4	3	0/1/0/0	0/3	-	-	-	3	-	-	-	-
PIC16F1788	28K	28	11 × 12-bit	4	2	3/1/0/0	0/3	-	-	-	3	-	-	-	-
PIC16F1789	28K	40	14 × 12-bit	4	3	3/1/0/0	0/3	-	-	-	3	-	-	-	-

# Focus Microchip Products

## 16-BIT PIC® MICROCONTROLLERS

Device	Flash Memory (B)	Pins	ADC	Comparator	Op Amps	DAC (5b/8b/9b/10b)	PWM (10b/16b)	CLC	NCO	CWG/COG	PSMC	HRPWM	Slope Compensation	ZCD	High-Current Drive (50 mA/100 mA)
dsPIC33FJ64GS610	64K	100	24 × 10-bit	4	–	0/0/0/1	9 × 2	–	–	–	–	–	–	–	–
dsPIC33FJ64GS608	64K	80	16 × 10-bit	4	–	0/0/0/1	8 × 2	–	–	–	–	–	–	–	–
dsPIC33FJ64GS606	64K	64	16 × 10-bit	4	–	0/0/0/1	6 × 2	–	–	–	–	–	–	–	–
dsPIC33FJ64GS406	64K	64	16 × 10-bit	0	–	–	6 × 2	–	–	–	–	–	–	–	–
dsPIC33FJ32GS610	32K	100	24 × 10-bit	4	–	0/0/0/1	9 × 2	–	–	–	–	–	–	–	–
dsPIC33FJ32GS608	32K	80	16 × 10-bit	4	–	0/0/0/1	8 × 2	–	–	–	–	–	–	–	–
dsPIC33FJ32GS606	32K	64	16 × 10-bit	4	–	0/0/0/1	6 × 2	–	–	–	–	–	–	–	–
dsPIC33FJ32GS406	32K	64	16 × 10-bit	–	–	–	6 × 2	–	–	–	–	–	–	–	–
dsPIC33FJ16GS504	16K	44	12 × 10-bit	4	–	0/0/0/1	4 × 2	–	–	–	–	–	–	–	–
dsPIC33FJ16GS502	16K	28	8 × 10-bit	4	–	0/0/0/1	4 × 2	–	–	–	–	–	–	–	–
dsPIC33FJ16GS404	16K	44	8 × 10-bit	–	–	–	3 × 2	–	–	–	–	–	–	–	–
dsPIC33FJ16GS402	16K	28	8 × 10-bit	–	–	–	3 × 2	–	–	–	–	–	–	–	–
dsPIC33FJ06GS202	6K	28	6 × 10-bit	2	–	0/0/0/1	2 × 2	–	–	–	–	–	–	–	–
dsPIC33FJ06GS102	6K	28	6 × 10-bit	–	–	–	2 × 2	–	–	–	–	–	–	–	–
dsPIC33FJ06GS101	6K	18	6 × 10-bit	–	–	–	2 × 2	–	–	–	–	–	–	–	–
dsPIC33FJ09GS302	9K	28/36	8 × 10-bit	2	–	0/0/0/1	3 × 2	–	–	–	–	–	–	–	–
dsPIC33FJ06GS202A	6K	28/36	6 × 10-bit	2	–	0/0/0/1	2 × 2	–	–	–	–	–	–	–	–
dsPIC33FJ06GS102A	6K	28/36	6 × 10-bit	–	–	–	2 × 2	–	–	–	–	–	–	–	–
dsPIC33FJ06GS101A	6K	18/20	6 × 10-bit	–	–	–	2 × 2	–	–	–	–	–	–	–	–
dsPIC33FJ06GS001	6K	18/20	6 × 10-bit	2	–	–	2 × 2	–	–	–	–	–	–	–	–

## Focus Analog Products

### DIGITALLY-ENHANCED PWM CONTROLLERS WITH INTEGRATED MCU

Device	Description	Topology Support	Vsupply (V)	Fsw (Max)	Program Memory Size (k words)	RAM (bytes)	Operating Temperature (°C)
MCP19110/1	Synchronous buck controller, integrated MCU, LDO and synchronous MOSFET driver, user configurable/programmable	Buck	4.5–32	1600	4	256	–40 to +125
MCP19114/5	Low-side drive PWM controller offers multiple power conversion topology support, integrated MCU, LDO and synchronous low-side MOSFET driver, user configurable/programmable	Boost, Flyback, SEPIC, Cuk	4.5–42	2000	4	256	–40 to +125

### ANALOG PWM CONTROLLER WITH INTEGRATED MOSFET DRIVER

Device	Description	Topology Support	Vsupply (V)	Iq (mA)	Fsw (kHz) (Max)	Operating Temperature (°C)
MCP1630	Current-mode PWM controller with integrated low-side MOSFET driver	Boost, SEPIC, Flyback	2.7–5.5	2.8	1000	–40 to +125
MCP1631/ MCP1631HV	Current-mode PWM controller with integrated low-side MOSFET driver, integrated 16V LDC	Boost, SEPIC, Flyback	3–16	3.7	2000	–40 to +125
MCP1632	Current- or voltage-mode PWM controller with integrated low-side MOSFET driver	Boost, Buck-Boost, Flyback, SEPIC, Cuk	3.0–5.5	5	600	–40 to +125

### SEQUENTIAL LINEAR LED DRIVER

Device	Vin (VAC)	Vout (VDC)	Ouput Current (peak)	Dimming	Parallelable	Packages	Features
CL8800	90–275	70–350	115 mA	External dimmer	✓	33-pin QFN	6-Stage
CL8801	90–275	70–350	200 mA	External dimmer	✓	33-pin QFN	4-Stage

### VOLTAGE REGULATORS

Device	Topology Support	Vsupply (V)	Output Voltage (V)	Output Current (mA)	Iq (Typical) (µA)	Fsw (kHz)	Operating Temperature (°C)
MCP1623/4	Boost	0.35–5.5	2.0–5.5	175	19	500	–40 to +85
MCP16251/2	Boost	0.82–5.5	1.8–5.5	225	14	500	–40 to +125
MCP1640	Boost	0.65–5.5	2.0–5.5	350	19	500	–40 to +85
MCP1643	Boost	0.5–5.0 (HV: 36V)	0.6–5.0	550	30	1000	–40 to +85
MCP16301/HV	Buck	4.0–30	2.0–15	600	2000	500	–40 to +125
MCP16311/2	Buck	4.4–30	2.0–24	1000	85	500	–40 to +125

# Focus Microchip Products

## Focus Analog Products

POWER MOSFET DRIVER							
Device	Description	Number of Channels	Vsupply (V)	Peak Drive Strength (A)	Output Resistance (R <sub>H</sub> /R <sub>L</sub> , Ω-max)	Input/Output Delay (ns)	Operating Temperature (°C)
MCP1401/ MCP1402	Low-side MOSFET Drivers, 0.5A Peak Output Current	Single	18	0.5	12/10	35/35	-40 to +125
MCP1415/ MCP1416	Low-Side MOSFET Drivers, 1.5A Peak Output Current	Single	18	1.5	6/4	41/48	-40 to +125
MCP14E6/7/8	Low-Side MOSFET Drivers, 2.0A Peak Output Current	Dual	18	2.0	5/5	45/45	-40 to +125
MCP14E9/10/11	Low-Side MOSFET Drivers, 3.0A Peak Output Current	Dual	18	3.0	4/4	45/45	-40 to +125
MCP14E3/4/5	Low-Side MOSFET Drivers, 4.0A Peak Output Current	Dual	18	4.0	2.5/2.5	56/50	-40 to +125
MCP14628	Synchronous (High-Side/Low-Side) MOSFET Driver	Dual (high/low)	5	2.0, 3.5 (low side sink only)	1.0/1.0 (high side) 1.0/0.5 (low side)	15/18 (high side) 16/22 (low side)	-40 to +85
MCP14700	Synchronous (High-Side/Low-Side) MOSFET Driver	Dual (high/low)	5	2.0, 3.5 (low side sink only)	1.0/1.0 (high side) 1.0/0.5 (low side)	27/27 (high side) 17/17 (low side)	-40 to +125

HIGH-VOLTAGE, LOW-SIDE BUCK LED DRIVER ICS							
Device	Internal Reference	External Reference	Control Algorithm	Mode	Input Voltage	Packages	
HV9910B	250 mV ± 10%	V <sub>LD</sub> ± 12 mV	Peak-current mode controller	Fixed freq./Fixed ToFF	8-450V	8-pin SO, 16-pin SO	
HV9910C	250 mV ± 10%	V <sub>LD</sub> ± 12 mV	Peak-current mode controller	Fixed freq./Fixed ToFF	15-450V	8-pin SO, 16-pin SO	
HV9961	275 mV ± 3%	0.182-0.188 V <sub>LD</sub> ± 10 mV	Average-current mode controller	Fixed ToFF	8-450V	8-pin SO, 16-pin SO	
HV9861A	270 mV ± 3%	0.175-0.182 V <sub>LD</sub> ± 10 mV	Average-current mode controller	Fixed ToFF	15-450V	8-pin SO, 16-pin SO	
HV9803	-	0.49 V <sub>LD</sub> ± 16 mV	Average-current mode controller	Fixed ToFF	8-16V	8-pin SO	
HV9803B	-	0.495 V <sub>LD</sub> ± 16 mV	Average-current mode controller	Fixed ToFF	8-16V	8-pin SO	

BOOST/SEPIC LED DRIVERS				
Device	Number of Channels	Input Voltage	Main Features	Packages
HV9911	1	9-250V	Latched mode output short circuit and open circuit protection	16-pin SO
HV9912	1	9-90V	Hiccup mode output short circuit and open circuit protection	16-pin SO
HV9964	1	8-40V	High PWM dimming ratio (> 10,1000:1), Latched mode open-loop protection	16-pin SO
HV9982	3	10-40V	Three channel LED driver, Hiccup mode output short circuit and open circuit protection	40-pin QFN
HV9985	3	10-40V	Three channel LED driver optimized for driving logic level FETs	40-pin QFN
HV9986	3	10-40V	Independent open circuit and short circuit protection for each channel	40-pin QFN

DC/DC LED DRIVER ICS							
Device	Input Voltage	Topology Support	Control Algorithm	Main Features	Automotive Qualified	Packages	
HV9918	4.5-40V	Buck	Hysteretic	Integrated 40V, 1Ω switching FET, On-board Analog-to-PWM conversion	-	8-pin DFN	
HV9919B	4.5-40V	Buck	Hysteretic	0.5A source and 1A sink gate driver for logic level FETs, On-board Analog-to-PWM conversion	-	8-pin DFN	
HV9930	8-200V	Boost-Buck (Ćuk)	Hysteretic	Programmable input current limit, Excellent input voltage transient rejection	-	8-pin SO	
HV9967B	8-60V	Buck	Average mode	Integrated 60V, 0.8Ω switching FET, Output short circuit and over temperature protection	-	8-pin MSOP, 8-pin DFN	
AT9917	5.3-40V	Boost/SEPIC	Closed loop/ Fixed Freq.	Programmable thermal fold back profile, low shutdown quiescent current	✓	24-pin TSSOP	
AT9919B	4.5-40V	Buck	Hysteretic	0.5A source and 1A sink gate driver for logic level FETs, On-board Analog-to-PWM conversion	✓	8-pin DFN	
AT9932	5.3-40V	Boost-Buck (Ćuk)	Closed loop/ Fixed Freq.	Excellent input voltage transient rejection, Programmable thermal fold back profile	✓	24-pin TSSOP	
AT9933	8-75V	Boost-Buck (Ćuk)	Hysteretic	Programmable input current limit, Excellent input voltage transient rejection	✓	8-pin SO	

THERMAL MANAGEMENT: Temperature Sensors							
Device	Description	# Temps Monitored	Typical/Max Accuracy (°C)	Operating Temperature (°C)	Vcc Range (V)	Typical Supply Current (µA)	
MCP9800/1/2/3	SMBus/I <sup>2</sup> C™ temperature sensor	1	0.5/1.0	-40 to +125	2.8-5.5	200	
TCN75A	SMBus/I <sup>2</sup> C temperature sensor	1	0.5/3.0	-40 to +125	2.8-5.5	200	
MCP9700/01	Voltage output temperature sensor	1	1.0/4.0	-40 to +125	2.3-5.5	200	
EMC1412/3/4	SMBus/I <sup>2</sup> C multi temperature sensor	2/3/4	0.25/1/0	-40 to +125	3.0-3.6	430	
MCP9808	SMBus/I <sup>2</sup> C temperature sensor	1	0.25/5.0	-40 to +125	2.7-5.5	200	
MCP9501/2/3/4	Factory programmed temperature switch	1	1/6	-40 to +125	2.7-5.5	25	
MCP9509/10	Resistor programmable temperature switch	1	0.5/2	-40 to +125	2.7-5.5	30	

# Focus Microchip Products

## Focus Communication Products

WIRELESS PRODUCTS							
Product	Pins	Frequency Range (GHz)	Sensitivity (dBm)	Power Output (dBm)	MAC	Protocols	Encryption
IEEE 802.11 Modules							
RN171	49	2.412–2.484	–83	0 to +12	Yes	DHCP, DNS, ARP, ICMP, FTP client, HTTP client, TCP, UDP	WEP, WPA, WPA2, EAP
MRF24WG0MA	36	2.412–2.484	–95	18	Yes	Wi-Fi® Connection Manager, Announce, DNS, DDNS, DHCP, FTP, HTTP, NBNS, SNMP, SNTP, SSL, TCP, UDP, ZeroConf <sup>(1)</sup>	WPA2-PSK, WPA-PSK, WEP, WPA2-ENTERPRISE
MRF24WG0MB	36	2.412–2.484	–95	18	Yes	Wi-Fi Connection Manager, Announce, DNS, DDNS, DHCP, FTP, HTTP, NBNS, SNMP, SNTP, SSL, TCP, UDP, ZeroConf <sup>(1)</sup>	WPA2-PSK, WPA-PSK, WEP, WPA2-ENTERPRISE
RN131	44	2.412–2.484	–85	18	Yes	DHCP, DNS, ARP, ICMP, FTP client, HTTP client, TCP, UDP	WEP, WPA, WPA2, EAP
IEEE 802.15.4 Transceivers/Modules							
MRF24J40	40	2.405–2.48	–95	0	Yes	ZigBee®, MiWi™ wireless networking protocol	AES128
MRF24J40MA	12	2.405–2.48	–95	0	Yes	ZigBee, MiWi wireless networking protocol	AES128
MRF24J40MD	12	2.405–2.48	–104	20	Yes	ZigBee, MiWi wireless networking protocol	AES128
MRF24J40MC	12	2.405–2.48	–108	20	Yes	ZigBee, MiWi wireless networking protocol	AES128

1. Supported in the provided stack.

Bluetooth®							
Product	Pins	Frequency Range (GHz)	Sensitivity (dBm)	Power Output (dBm)	MAC	Profiles	
RN42	35	2.4 to 2.48	–80	4	Yes	SPP, DUN, HID, iAP, HCI, RFCOMM, L2CAP, SDP	
RN41	35	2.4 to 2.48	–80	15	Yes	SPP, DUN, HID, iAP, HCI, RFCOMM, L2CAP, SDP	

Sub-GHz Transceivers/Modules								
Product	Pins	Frequency Range (MHz)	Sensitivity (dBm)	Power Output (dBm)	RSSI	Clock	Interface	
MRF49XA	16	433/868/915	–110	7	Yes	10 MHz	4-wire SPI	
MRF89XA	32	868/915/950	–113	12.5	Yes	12.8 MHz	4-wire SPI	
MRF89XAM8A	12	868	–113	12.5	Yes	12.8 MHz	4-wire SPI	
MRF89XAM9A	12	915	–113	12.5	Yes	12.8 MHz	4-wire SPI	

ETHERNET PRODUCTS							
Device Family	Pins	MCU + Ethernet	Integrated MAC + PHY	Interface	Hardware Security	Pre-programmed MAC	Additional Features
PIC18F97J90	64–100	✓	✓ (10Base-T)	–	–	–	IEEE 802.3™ compliant, Auto-negotiation, Configurable buffer
PIC32MX795F512	64–100	✓	✓ (10/100Base-T)	–	–	✓	
ENC28J60	28	–	✓ (10Base-T)	SPI	–	–	
ENC624J600	44–64	–	✓ (10/100Base-T)	SPI/Parallel	✓	✓	

USB PRODUCTS						
Device Family	Pins	Flash (KB)	Voltage (V)	Crystal-Free	Additional Features	
 PIC16(L)F1459	14–20	7–14	1.8–5.5	✓	CWG, 10-bit ADC, DAC, I <sup>2</sup> C™, SPI, UART	
 PIC18(L)F45K50	28–44	16–32	1.8–5.5	✓	10-bit ADC, Comparators, ECCP, UART, SPI, I <sup>2</sup> C	
 PIC18F97J94	64–100	32–128	2–3.6	✓	VBAT, 12-bit ADC, LCD, ECCP, UART, I <sup>2</sup> C, SPI, Comparators	
PIC32MX220F032	28–44	16–32	2.3–3.6	–	PWM, 10-bit ADC, SPI, UART, I <sup>2</sup> C, I <sup>2</sup> S™	

CAN AND LIN PRODUCTS							
Device Family	Pins	Flash (KB)	CAN Tx Buffers	CAN Rx Buffers	LIN Tx Rx	Voltage (V)	Additional Features
PIC18F4685	28–44	16–96	3	2	–	2–5.5	LIN USART
PIC18F66K80	28–64	32–64	3	2	–	1.8–5.5	LIN USART
PIC16F1829LIN	14	8K	–	–	Integrated	2.3–5.5	LIN USART
PIC32MX564F128	64–100	16–128	32	32	–	2.3–3.6	LIN USART

# Reference Designs and Proofs-of-Concepts

Go to [www.microchip.com/lighting](http://www.microchip.com/lighting) and select 'Tools → Development & Reference Designs' to download the latest design schematics, firmware, application notes and collateral. Contact your local sales representative to evaluate working demonstration platforms.

## PIC16F1947 mTouch Technology Intelligent Lighting Controller

### Highlights

- PIC16F1947-based design with AC/DC power conversion
- Panel technology and backlighting provided by Lumvatech
- Wall controller
  - Backlit buttons wake up with mTouch technology
- mTouch technology capacitive sensing through light buttons
  - Visually interactive buttons and slider
  - Varying light intensity to indicate pressure
- Variable luminaire control
  - DALI
  - MiWi wireless networking protocol
  - Phase-cut (TRIAC)
- Customizable
  - Buttons, graphics, operating modes
  - Communication (DALI, DMX512A, RF, etc.)

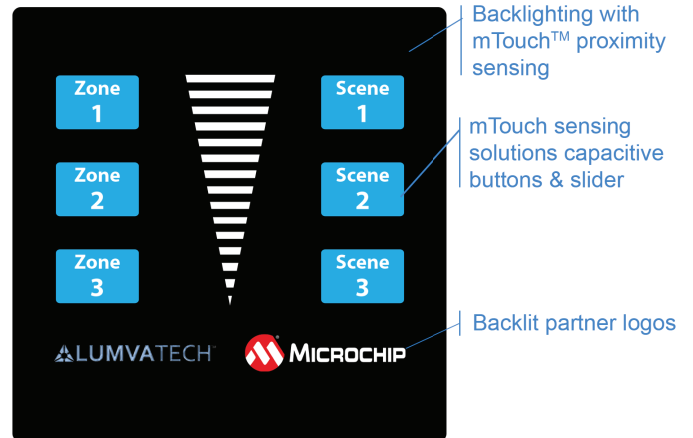

# Reference Designs and Proofs-of-Concepts

## PIC12F1572 RGB Color Mixing Demonstration

### Highlights

- High-resolution color mix with Cree RGB LED **PIC12F1572** Controlled Topology
  - Three standalone 16-bit PWMs with independent time base
  - 4 channel 10-bit ADC with voltage reference
  - 5-bit DAC
  - Comparator
  - Complementary Waveform Generator (CWG)
  - EUSART
- **PIC16F1455** integrated USB and Active Clock Tuning **MCP1640** boost DC/DC regulator

### Two Modes of Operation

- *Mode 1:* PIC12F1572 with MCP1640
  - mTouch technology color control slider
  - Auto rotation of custom color mix
  - Battery system power
- *Mode 2:* PIC12F1572 with PIC16F1455
  - USB connectivity for chromaticity selector GUI
  - USB system power

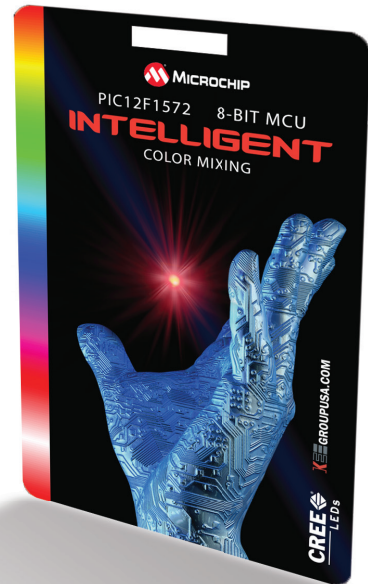

### Block Diagram

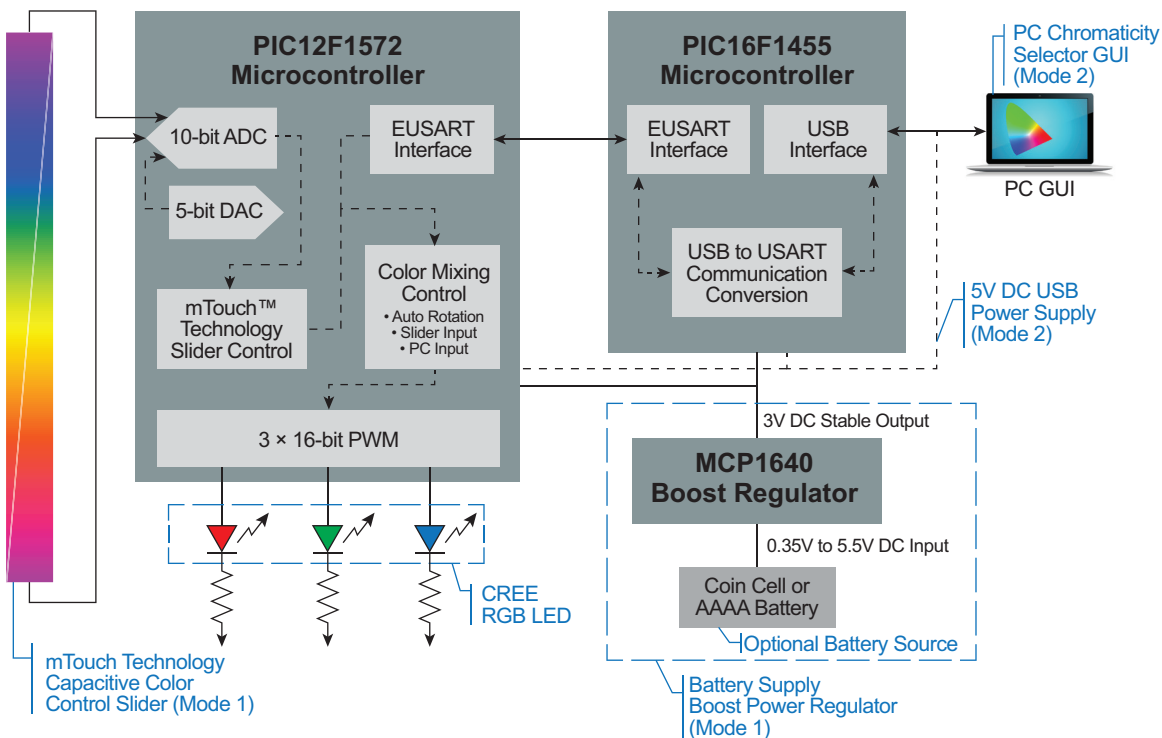

# Reference Designs and Proofs-of-Concepts

## PIC12F752 High Power LED Flashlight

### Highlights

- DC/DC Buck Power Conversion
  - > 90% efficient buck power supply
- PIC12F752-based design
- Over temperature monitoring
- Upwards of 1000 lumen output at 10W
- Anodized aluminum enclosure
- Magnetic rotational mode selector
- Multiple operating modes
  - Low power (60 lumens @ 0.6W)
  - Medium power (200 lumens @ 2W)
  - High power (1000 lumens @ 10W)
  - SOS (customized lighting sequence)
- Long life operation
  - Low power = 31 hours @ 0.6W
  - Medium power = 8.5 hours @ 2W
  - High power = 1.5 hours @ 10W

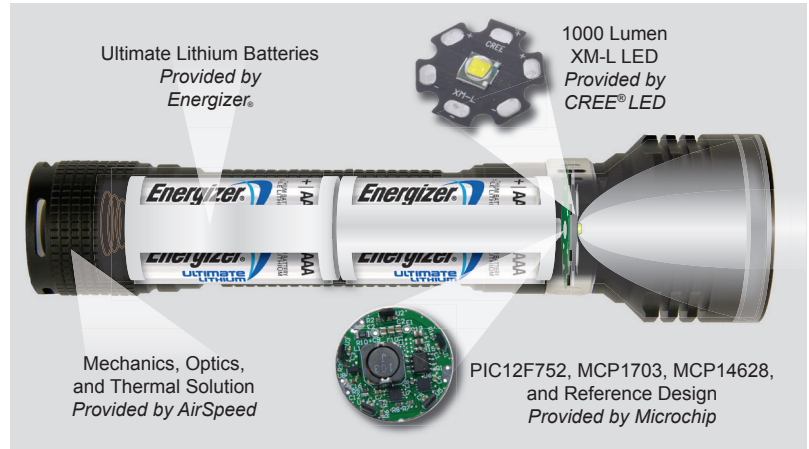

### Block Diagram

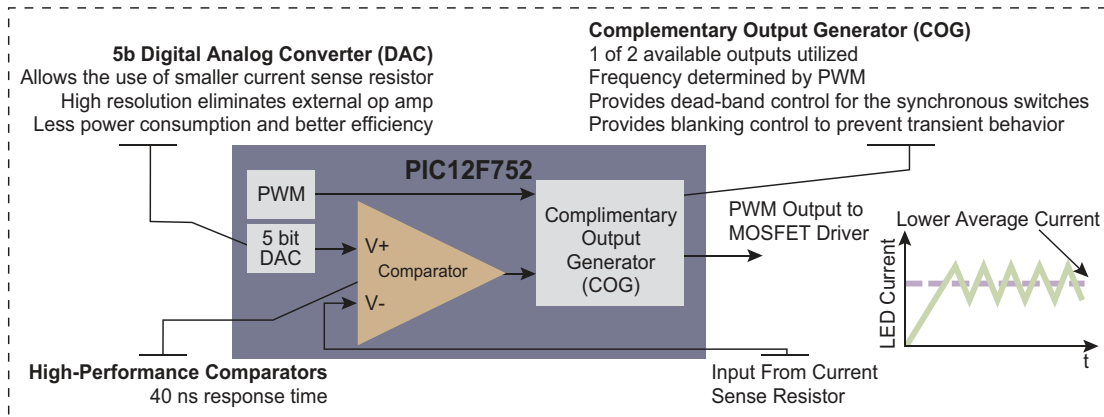
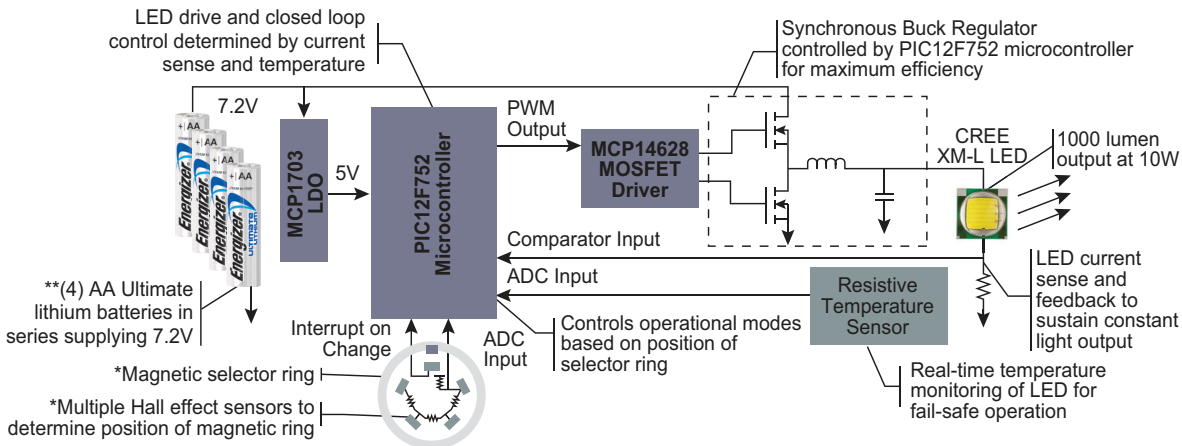



# Reference Designs and Proofs-of-Concepts

## PIC12F752 AC/DC LED Driver

### Highlights

- AC/DC flyback power supply
  - ~85% Efficiency
  - Active 0.95 Power Factor Correction (PFC)
  - 90–240 VAC input
    - Single hardware platform
    - Firmware based configuration
  - 20 V<sub>DC</sub>/375 mA output
- **PIC12F752**-controlled topology
  - Core independent peripheral integration
    - 5-bit DAC
    - Complementary Output Generator (COG)
    - High performance comparators
    - Hardware Limit Timer (HLT)
- **MCP1416** FET Driver
- TRIAC dimmable

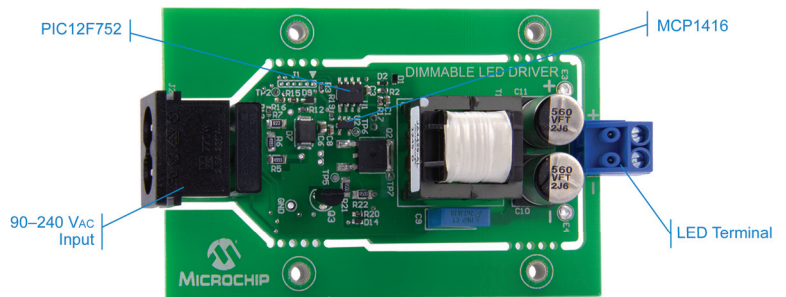

### Block Diagram

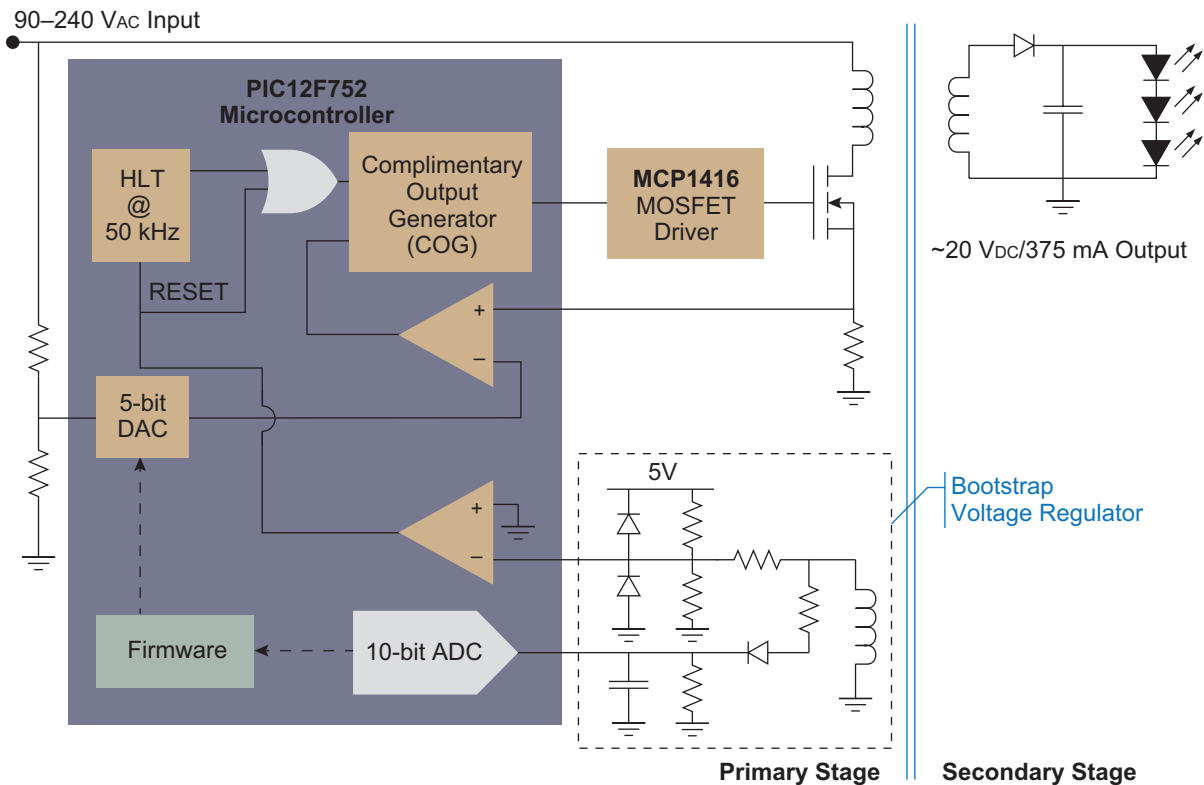

# Reference Designs and Proofs-of-Concepts

## PIC16F1788 Wireless DC/DC LED Driver

### Highlights

- DC/DC SEPIC power supply
  - ~90% Efficiency
  - 9–24 V<sub>DC</sub> input
  - 24 V<sub>DC</sub> output
- **PIC16F1788**-controlled topology
  - Core independent peripheral integration
    - Programmable Switch Mode Controller (PSMC)
    - High-performance 16-bit PWM
    - 10/12-bit ADC
    - High-performance comparators
    - 8-bit DAC
    - Op amps
- Current mode control
- Software PI control
- Variable frequency: 400–700 kHz
- **MCP1416** FET driver
- **MCP16301** voltage regulator
- Wireless communications
  - **MRF24J40MA** MiWi wireless networking protocol module
- Dimming support
  - 0–10V control
  - MiWi wireless networking protocol radio control

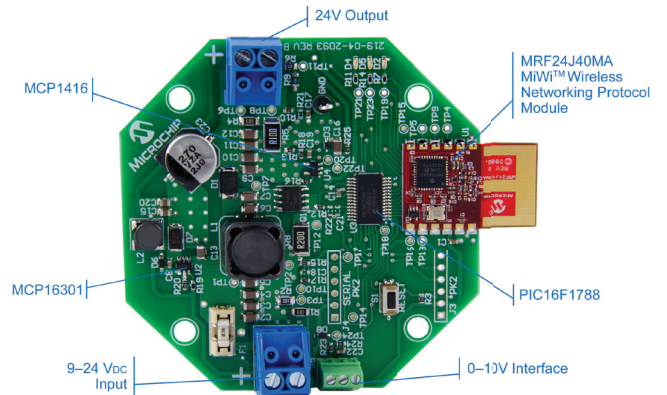

### Example Wi-Fi to MiWi Wireless Networking Protocol Topology

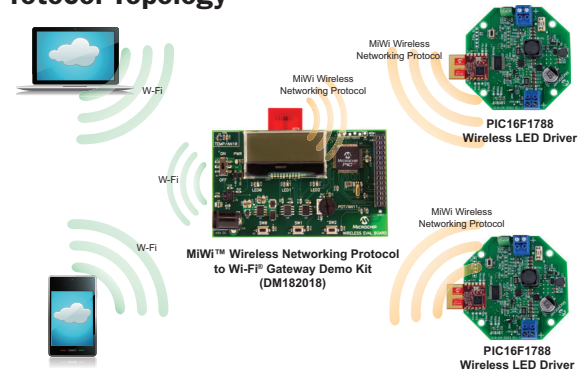

### Block Diagram

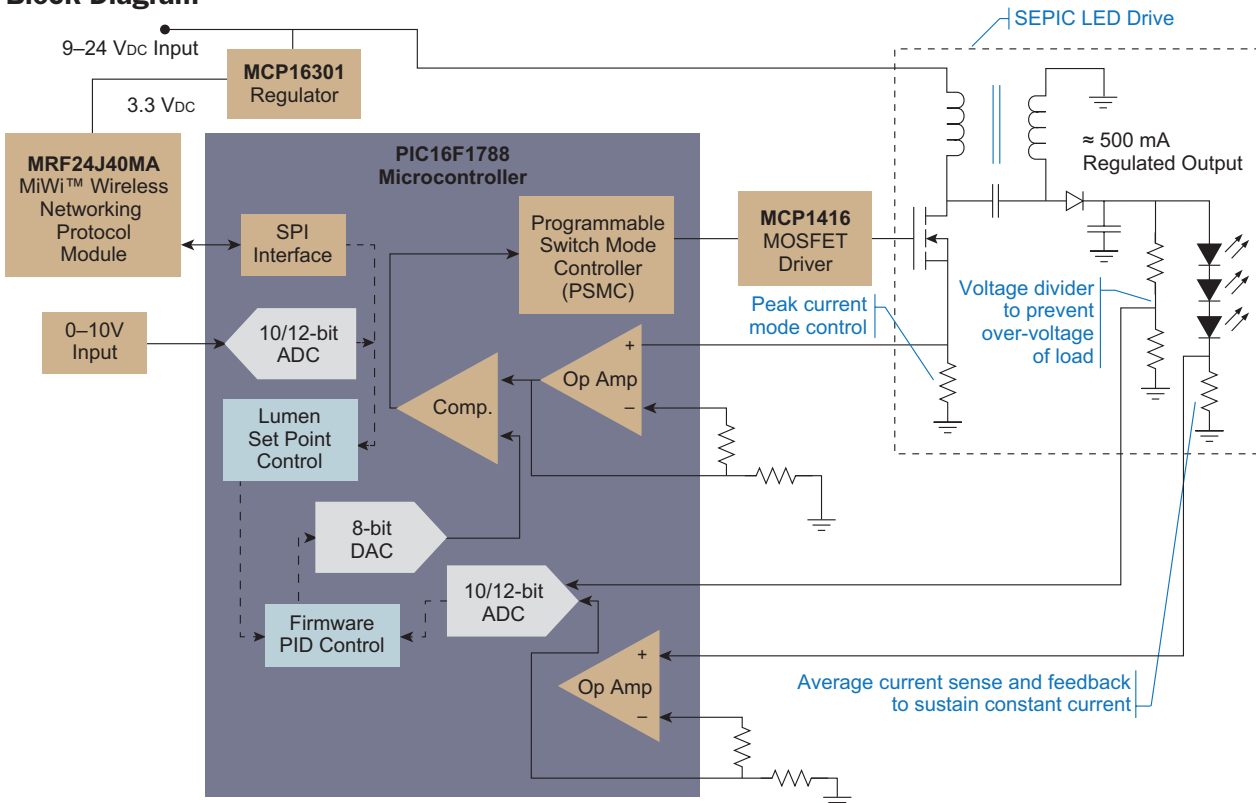

# Reference Designs and Proofs-of-Concepts

## PIC16F1509 Solar Powered LED Security Lamp

### Highlights

- DC/DC SEPIC power supply
  - ~ 85% Efficiency @ 500 mA charging current
  - 9–25 V<sub>dc</sub> input (compatible with 30–36 cell panels)
  - 6.8–7.2 V<sub>dc</sub> @ 500 mA DC output for battery charging
  - 9–24 V<sub>dc</sub> @ 350 mA DC output for LED driving
- **PIC16F1509**-controlled topology
- Core independent peripheral integration
  - Numerically Controlled Oscillator (NCO)
  - 10-bit Analog-to-Digital Converter (ADC)
- Maximum power point tracking (MPPT) solar charging to battery
- Night sensing via solar panel
- **MCP6V02** op amp for current shunt amplification and motion sensing via Passive Infrared (PIR) sensor
- **MCP1790** High Voltage Regulator
- Boost LED drive

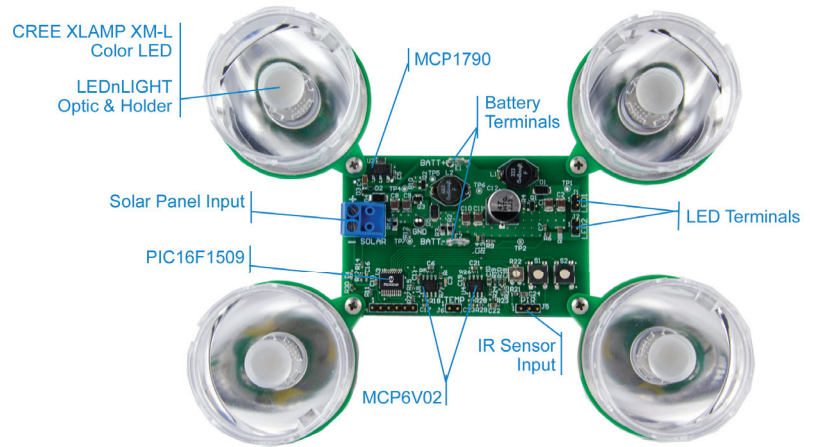

### Block Diagram

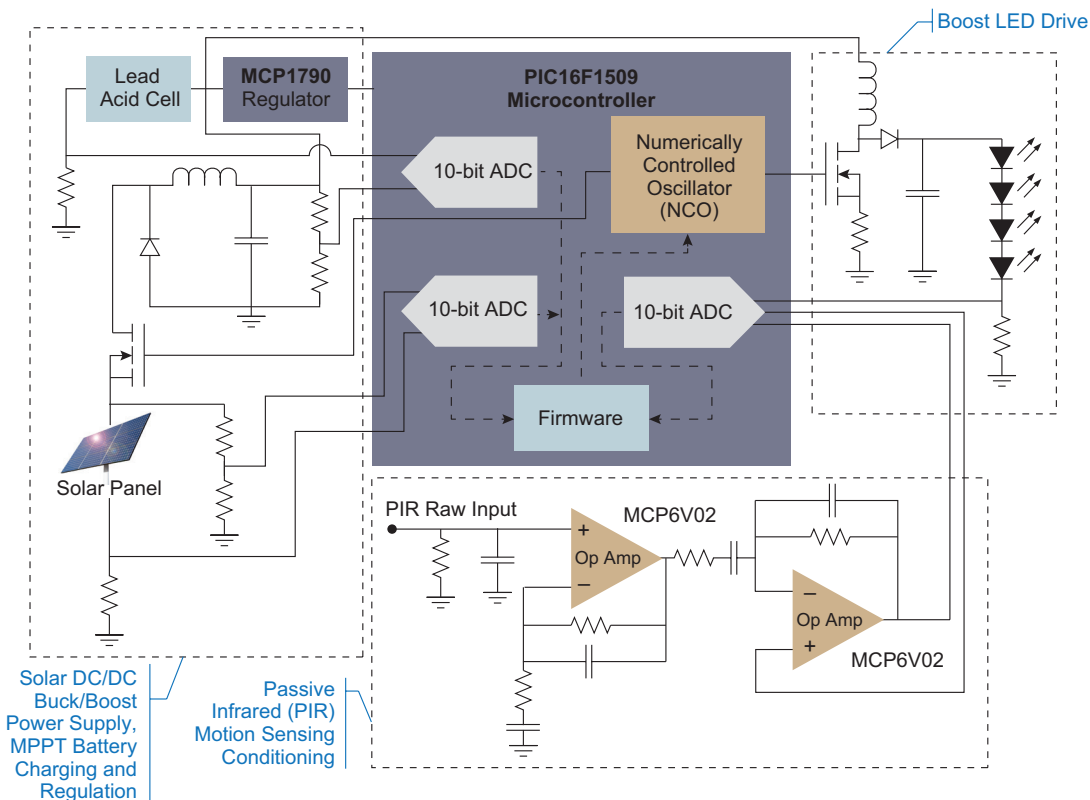

# Reference Designs and Proofs-of-Concepts

## PIC16F1508 DALI Dimmable Fluorescent Ballast

### Highlights

- AC/DC resonant power supply
  - Active Power Factor Correction (PFC)
  - ~90% Efficiency
  - 50 kHz Switching frequency
  - 120–240 VAC input
    - Single hardware platform
    - Firmware based configuration
- **PIC16F1508**-controlled topology
  - Core independent peripheral integration
    - 5-bit DAC, CLC, PWM, NCO and comparators
- DALI communications
- Smooth dimming control
  - Linear frequency control using NCO
- **MCP1416** FET Driver

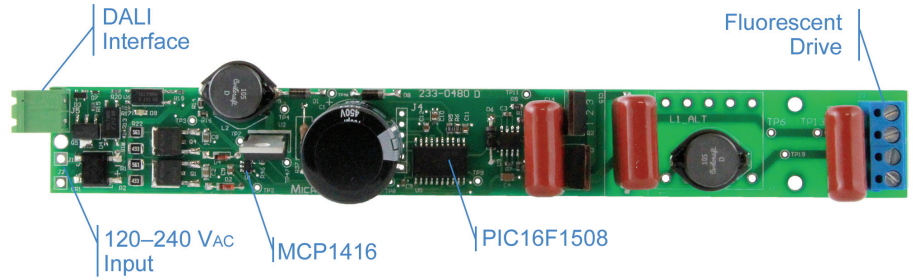

### Block Diagram

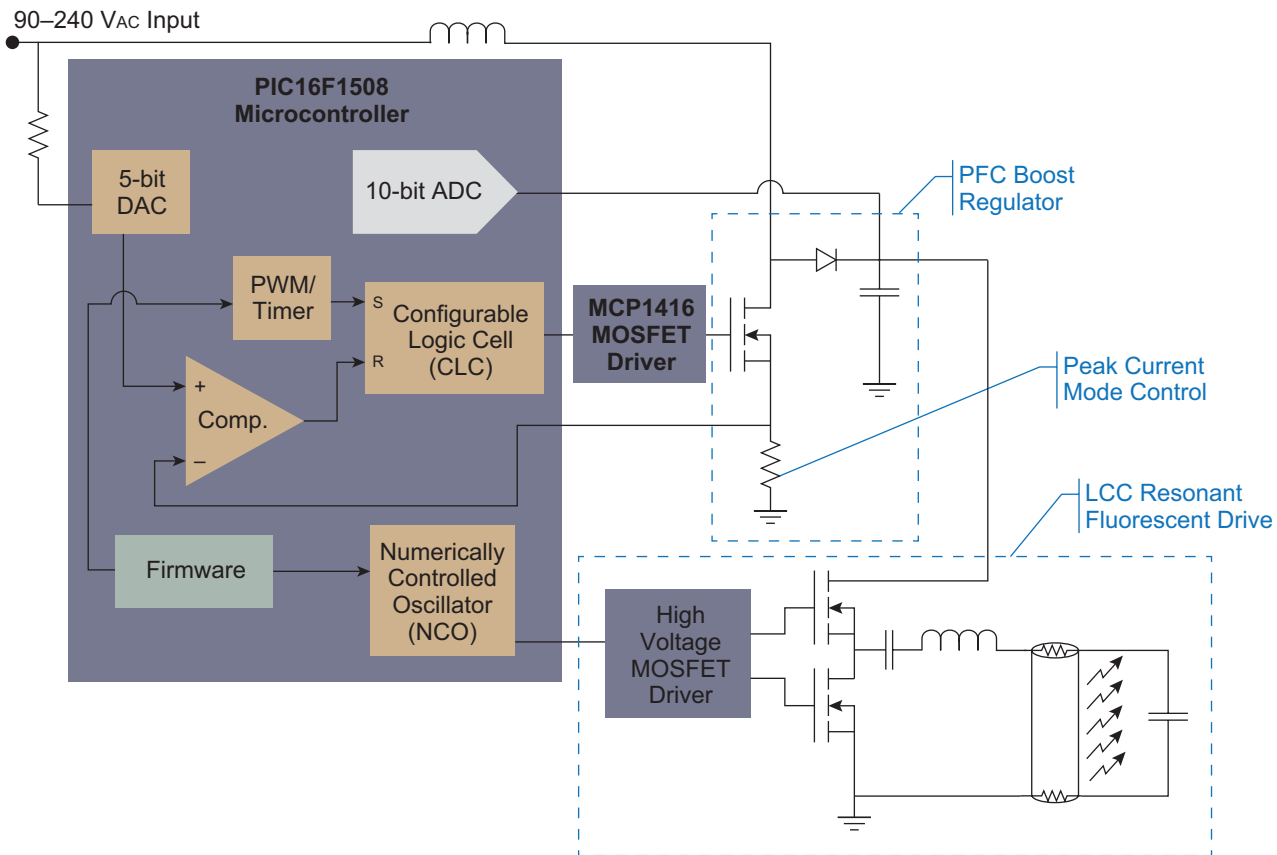

# Reference Designs and Proofs-of-Concepts

## Digital HID Ballast Reference Design

### Highlights

- dsPIC33FJ06GS202-based design
- Xenon HID lamp
- Full digital control HID ballast
  - Ignites HID bulb then transitions to steady-state operation
  - Less than 150 seconds to steady-state light output
- Flyback DC/DC boost converter
  - 9–16 V<sub>dc</sub> input
  - Greater than 85% efficiency
- Planar magnetic used to achieve small size
  - 9 mm × 60 mm × 80 mm
  - Commonly referred to as a “slim” ballast form factor
- Under voltage, over voltage, and over current protection

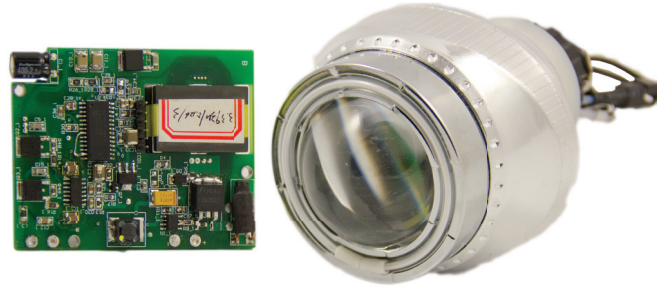

### Block Diagram

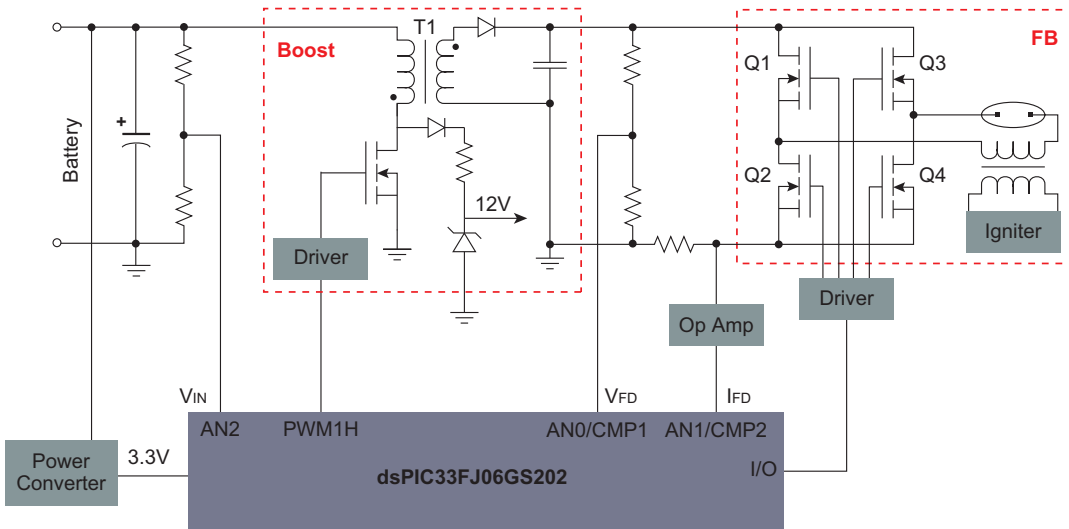

## High Resolution PWM Proof of Concept

### Highlights

- High Resolution PWM (HRPWM)
- >16-bit effective PWM resolution at high frequency (eg. ~16-bit @ 500 kHz)
  - Required peripherals: Numerically Controlled Oscillator (NCO) and Configurable Logic Cell (CLC)
  - Improved EMI performance
- RGBW color mixing control with four PIC microcontrollers with NCO/CLC
  - Single **PIC16F1509** for RED and high-resolution color processing
  - Single **PIC10F322** per GREEN, BLUE, WHITE channel
  - Variable LED frequency based on brightness: 500 Hz to 64 kHz
    - 16 to 21-bits effective PWM resolution
- USB and DMX512A capable via **PIC16F1455**

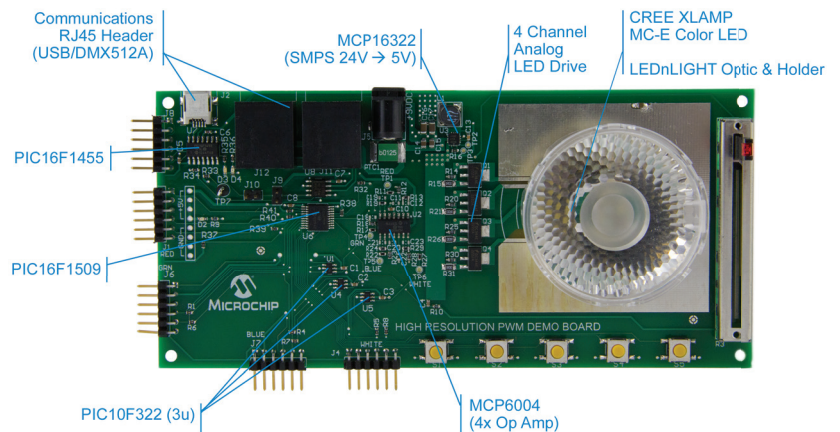

Note: See Application Note AN1476

# Development Tools and Demonstration Platforms

Go to [www.microchip.com/lighting](http://www.microchip.com/lighting) and select 'Tools → Development & Reference Designs' to purchase as well as download the latest design schematics, firmware, application notes, and collateral.

## Lighting Communications Development Platform

- Universal lighting protocol development
- FREE 'C' library stack (DALI, DMX512A)
- Dimming and color mixing control
- Customizable capabilities

### Main Communication Board Highlights (DM160214)

- Populated with PIC16F1947 controlling:
  - Communications
  - User interface: LCD, buttons, slider
  - LED constant current drive
- Populated with Cree XLamp MC-E Color LED
- Populated with the LEDnLIGHT optic and holder

### Prototyping Communication Board Highlights (AC160214)

- Populated with PIC16F1947 for user interface and communications
- Breadboarding space for customized lighting development

### Universal Communications Adapter Interface

- DALI adapter (DM160214-1)
- DMX512A adapter (DM160214-2)



Available for purchase separately or as a kit

### DALI Starter Kit (DV160214-1) DMX512A Starter Kit (DV160214-2)

- Two DALI or (two) DMX512A adapters
- Two Main communication boards
- Prototyping communication board
- 9V international power supply
- RJ45 patch cable

For more information, visit [www.microchip.com/lightingcomms](http://www.microchip.com/lightingcomms).

### MCP16301 LED Driver Demonstration Board (MCP16301 – ARD00410)



- **MCP16301** Cuk-based LED driver demonstration
- 300 mA constant current source
- Input operating voltage from 6–18 Vdc

### MCP1630 Boost Mode LED Driver Demonstration Board (MCP1630DM-LED2)



- **MCP1630** Boost LED driver demo
- 350 or 700 mA constant current source
- Input operating voltage range of 9–16 Vdc
- Maximum power output of 30W

### MCP1631HV Digitally Controlled Programmable Current Source Reference Design (MCP1631RD-DCPC1)



- **MCP1631** SEPIC LED driver demonstration
- Input voltage range of 3.5–16 Vdc
- Maximum power output of 8.5W

### MCP1650 Multiple White LED Demonstration Board (MCP1650DM-LED2)



- **MCP1650** Boost LED driver demo
- Nine LED string in series
- **PIC10F202** controlled
  - Enable control of **MCP1650**
  - Push-button input for LED intensity adjustment

### MCP1252 Charge Pump Backlight Demonstration Board (MCP1252DM-BKLT)



- LED backlighting demonstration
- **MCP1252** evaluation platform
- Light intensity controlled via ballast resistors
- **PIC10F206** controlled
  - Enable control of **MCP1252**
  - Push-button input for LED intensity adjustment

### Digital LED Lighting Development Kit (DM330014)

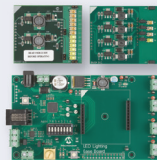

- 100% digitally controlled LED driver
- Fully controlled with a single **dsPIC33FJ16GS504** DSC
- RGB LED driver with DMX512 support for brightness control
- Dimming and color hue control
- Flexible input voltage support, including buck and boost topologies
- Fully dimmable, full digital control, Fault protection
- Advanced features implemented in software

### MCP1650 3W White LED Demonstration Board (MCP1650DM-LED1)



- **MCP1650** Boost LED driver demonstration
- Nine LED string in series
- **PIC10F202** controlled
  - Enable control of **MCP1650**
  - Push-button input for LED intensity adjustment

# Microchip's Partner Network

Leveraging the expertise and products from Microchip's lighting partners further ensures quick development of quality advanced lighting products.

Interested in becoming a collaborative or design partner? Let us know at [lighting@microchip.com](mailto:lighting@microchip.com).

## Design Partners

Microchip recognizes the challenges involved in developing advanced lighting solutions and has created a Design Partner network to ease your development efforts. Microchip's Intelligent Lighting and Control Design Partner Specialists have proven lighting design expertise and can reduce your time to market.

Go to [www.microchip.com/lighting](http://www.microchip.com/lighting) and select 'Resources> Support' for a full list of companies offering design services and support for your intelligent lighting development needs.



## Collaborative Partners

To ensure the development of the most innovative lighting solutions, Microchip works with industry leaders to collaborate on various reference designs, demonstrations, and development tools. Creating the most effective lighting solution requires products—from integrated circuits, to light sources, optics, thermals and mechanics—expertise and services from a multitude of sources.

Collaborative Partners	
<p><b>CREE</b>   ▶ LED Solution Provider</p>	<p><b>Cree, Inc</b> leads the industry through performance and application optimized lighting-class LEDs that simplify design and lower system costs to obsolete energy-wasting traditional lighting. Cree's relentless innovation drives the LED lighting revolution with products designed to accelerate LED adoption and push the boundaries of what's possible with LED lighting. Cree's LED product families include XLamp® and High Brightness LEDs.</p>
<p><b>lednlight</b></p>	<p><b>LEDnLIGHT</b> optics are made by Gaggione SAS the—Montréal La Cluse, France, plastic optics manufacturer—who produces the very narrow beam collimator providing excellent color mixing properties to address stage lighting, entertainment lighting and architectural lighting applications, to name a few. Gaggione is an ISO 9001 and ISO TS 16949 certified company and a leader in producing solutions using polymers for customers around the world. The company provides comprehensive design, development and manufacturing capabilities for the production of standardized and customized polymer optics at their state-of-the-art production technologies and facilities in France, Switzerland and Canada.</p>
<p><b>LUMVATECH</b></p>	<p><b>Lumvatech</b> is a cutting-edge manufacturer of LED light panels and complete backlighting solutions. Lumvatech specializes in thin and flexible applications. From light panels to complete interactive capacitive touch solutions, Lumvatech manufactures a wide variety of standard or custom products and solutions.</p>
<p><b>AirSpeed</b></p>	<p>An experienced provider of innovative product solutions, <b>AirSpeed</b> specializes in the design and manufacturing of complete mechanical packages. The company's many years of experience in plastics, metal fabrication, die cast, cable assemblies and global logistics management ensures that customers can offer the most competitive product to the market.</p>
<p><b>Energizer</b></p>	<p><b>Energizer Holdings, Inc.</b>, headquartered in St. Louis, MO, is one of the world's largest manufacturers of primary batteries, portable flashlights and lanterns. <i>Energizer</i>® Ultimate Lithium batteries deliver long-lasting power to keep up with today's high-tech devices like digital cameras, LED flashlights and handheld GPS devices.</p>

## Support

Microchip is committed to supporting its customers in developing products faster and more efficiently. We maintain a worldwide network of field applications engineers and technical support ready to provide product and system assistance. In addition, the following service areas are available at [www.microchip.com](http://www.microchip.com):

- **Support** link provides a way to get questions answered fast: <http://support.microchip.com>
- **Sample** link offers evaluation samples of any Microchip device: <http://sample.microchip.com>
- **Forum** link provides access to knowledge base and peer help: <http://forum.microchip.com>
- **Buy** link provides locations of Microchip Sales Channel Partners: [www.microchip.com/sales](http://www.microchip.com/sales)

## Sales Office Listing

### AMERICAS

**Atlanta**  
Tel: 678-957-9614

**Austin**  
Tel: 512-257-3370

**Boston**  
Tel: 774-760-0087

**Chandler**  
Tel: 480-792-7200

**Chicago**  
Tel: 630-285-0071

**Cleveland**  
Tel: 216-447-0464

**Dallas**  
Tel: 972-818-7423

**Detroit**  
Tel: 248-538-2250

**Houston**  
Tel: 281-894-5983

**Indianapolis**  
Tel: 317-773-8323

**Los Angeles**  
Tel: 949-462-9523

**New York**  
Tel: 631-435-6000

**San Jose**  
Tel: 408-735-9110

**Toronto**  
Tel: 905-673-0699

### EUROPE

**Austria - Wels**  
Tel: 43-7242-2244-39

**Denmark - Copenhagen**  
Tel: 45-4450-2828

**France - Paris**  
Tel: 33-1-69-53-63-20

**Germany - Dusseldorf**  
Tel: 49-2129-3766400

**Germany - Munich**  
Tel: 49-89-627-144-0

**Germany - Pforzheim**  
Tel: 49-7231-424750

**Italy - Milan**  
Tel: 39-0331-742611

**Italy - Venice**  
Tel: 39-049-7625286

**Netherlands - Drunen**  
Tel: 31-416-690399

**Poland - Warsaw**  
Tel: 48-22-3325737

**Spain - Madrid**  
Tel: 34-91-708-08-90

**Sweden - Stockholm**  
Tel: 46-8-5090-4654

**UK - Wokingham**  
Tel: 44-118-921-5800

## Training

If additional training interests you, then Microchip can help. We continue to expand our technical training options, offering a growing list of courses and in-depth curriculum locally, as well as significant online resources – whenever you want to use them.

- Technical Training Centers and Other Resources: [www.microchip.com/training](http://www.microchip.com/training)
- MASTERS Conferences: [www.microchip.com/masters](http://www.microchip.com/masters)
- Worldwide Seminars: [www.microchip.com/seminars](http://www.microchip.com/seminars)
- eLearning: [www.microchip.com/webseminars](http://www.microchip.com/webseminars)

### ASIA/PACIFIC

**Australia - Sydney**  
Tel: 61-2-9868-6733

**China - Beijing**  
Tel: 86-10-8569-7000

**China - Chengdu**  
Tel: 86-28-8665-5511

**China - Chongqing**  
Tel: 86-23-8980-9588

**China - Hangzhou**  
Tel: 86-571-87928115

**China - Hong Kong SAR**  
Tel: 852-2943-5100

**China - Nanjing**  
Tel: 86-25-8473-2460

**China - Qingdao**  
Tel: 86-532-8502-7355

**China - Shanghai**  
Tel: 86-21-5407-5533

**China - Shenyang**  
Tel: 86-24-2334-2829

**China - Shenzhen**  
Tel: 86-755-8864-2200

**China - Wuhan**  
Tel: 86-27-5980-5300

**China - Xiamen**  
Tel: 86-592-2388138

**China - Xian**  
Tel: 86-29-8833-7252

**China - Zhuhai**  
Tel: 86-756-3210040

### ASIA/PACIFIC

**India - Bangalore**  
Tel: 91-80-3090-4444

**India - New Delhi**  
Tel: 91-11-4160-8631

**India - Pune**  
Tel: 91-20-3019-1500

**Japan - Osaka**  
Tel: 81-6-6152-7160

**Japan - Tokyo**  
Tel: 81-3-6880-3770

**Korea - Daegu**  
Tel: 82-53-744-4301

**Korea - Seoul**  
Tel: 82-2-554-7200

**Malaysia - Kuala Lumpur**  
Tel: 60-3-6201-9857

**Malaysia - Penang**  
Tel: 60-4-227-8870

**Philippines - Manila**  
Tel: 63-2-634-9065

**Singapore**  
Tel: 65-6334-8870

**Taiwan - Hsin Chu**  
Tel: 886-3-5778-366

**Taiwan - Kaohsiung**  
Tel: 886-7-213-7830

**Taiwan - Taipei**  
Tel: 886-2-2508-8600

**Thailand - Bangkok**  
Tel: 66-2-694-1351

3/12/14

Microcontrollers • Digital Signal Controllers • Analog • Memory • Wireless

Information subject to change. The Microchip name and logo, the Microchip logo, dsPIC, GestIC and PIC are registered trademarks and MiWi and mTouch are trademarks of Microchip Technology Incorporated in the U.S.A. and other countries. All other trademarks mentioned herein are property of their respective companies. © 2014, Microchip Technology Incorporated. All Rights Reserved. Printed in the U.S.A. 04/14  
DS00001036H

  
**MICROCHIP**  
[www.microchip.com](http://www.microchip.com)

Microchip Technology Inc.  
2355 W. Chandler Blvd.  
Chandler, AZ 85224-6199